



INSTRUCTIONS

-J04124

REV. 2006-05-17

CLASSIC COVERS ENGINE KIT

GENERAL

Kit Number

94943-07, 94944-07

Models

Table 1. Models

Kit	Kit Number	Models
A	94943-07	Twin Cam equipped models
B	94944-07	2004 and later Sportster models

Additional Parts May Be Required

NOTE

Because of the large variation of fitments between models and model years, you may find that you have extra covers remaining after the installation of this kit. You may also find that you may be short various covers after installing this kit. If this occurs, contact a Harley-Davidson dealer to purchase additional covers.

Kit Contents

NOTE

The different size and type covers are packaged (with part number on package) in groups. Refer to Table 2 to determine the recommended usage area and intended fastener for each group of covers. If ordering replacement covers from a Harley-Davidson dealer, the part number in Table 2 is for a quantity of 1 each.

Table 2. Kit Contents

	Intended Fastener	Recommended Usage (Not applicable to all models)	Part Number	Kit A	Kit B
1	1/4 inch size socket head cap screw	Various engine and transmission cover screws	94903-07	50	56
2	5/16 inch size socket head cap screw	Transmission side covers	94904-07	7	0
3	3/8 inch size socket head cap screw	Transmission housing	94906-07	3	3
4	5/16 inch size special hex/socket screw	Rocker box cover screws	94907-07	8	0
5	3/8 inch size hex bolts (9/16 inch hex)	Transmission to engine mounting screws	94915-07	3	0
6	5/16 inch size hex bolt (1/2 inch hex)	Engine case screws	94918-07	8	4
7	Silicone adhesive		Not sold separately (not shown)		

INSTALLATION

NOTE

Prior to final installation of covers, test fit covers over fasteners to determine correct fastener-to-cover fitment.

is03191

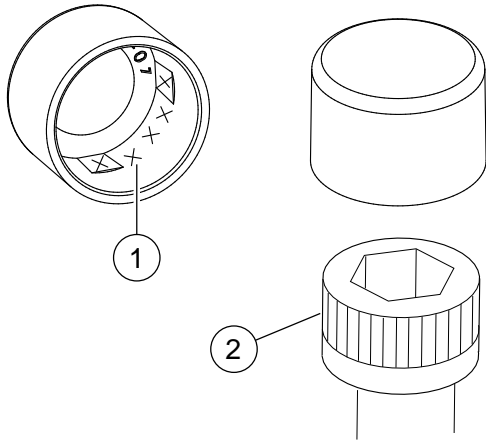

- 1. Adhesive application area
- 2. Socket head cap screw

Figure 1. Silicone Adhesive Application Area

NOTE

See Figure 1. This kit includes a container of silicone adhesive. Apply adhesive to the inside of cover (1) in areas marked with "x".

NOTE

All fasteners that will be covered must be clean and dry prior to cover installation. It is recommended that entire motorcycle be washed and completely dry. Pay particular attention to fastener heads.

- 1. Open only one part numbered bag of covers at a time. Start in one area of motorcycle and test fit covers over fasteners. Once correct fitment is confirmed, apply a small amount of silicone adhesive to inside of cover and install over fastener. Remove excess adhesive. Move to the next part numbered bag of covers and repeat process.
- 2. Allow silicone to cure for a minimum of 12 hours before operating the motorcycle.

is03192

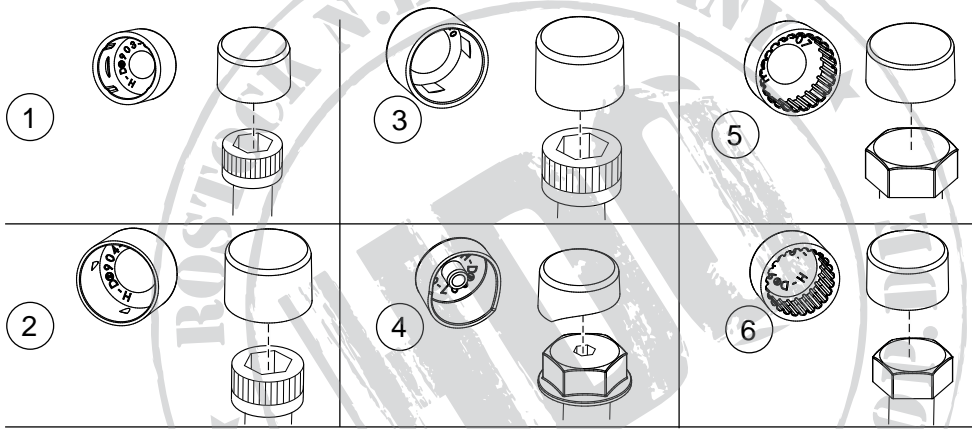

Figure 2. Classic Covers and Corresponding Fasteners