



# INSTRUCTIONS

-J01177

REV. 2011-05-06

## FAIRING MOUNT MIRRORS

### GENERAL

#### Kit Number

91945-98B, 92085-10, 56000029

#### Models

For model fitment information, see the P&A Retail Catalog or the Parts and Accessories section of [www.harley-davidson.com](http://www.harley-davidson.com) (English only).

#### Kit Contents

See Figure 2 and Table 1.

### INSTALLATION

#### Removing Outer Fairing

1. Standing at the front of the vehicle, use a T-27 TORX® drive head to remove the three outer fairing screws (with flat washers) just below the windshield.
2. Moving to the inner fairing side, use a T-27 TORX drive head to remove the two fairing screws just above the wind deflectors on the left and right side.
3. Turn handlebar to the right and remove outer fairing screw (reach in below the fairing cap). Turn the handlebar to the left and remove the fairing screw on the opposite side.
4. Tilting the outer fairing toward the front, squeeze the two external tabs to remove the wire connector at the back of the headlamp assembly.
5. Lift the fairing (with headlamp assembly) off the motorcycle.

#### NOTE

Since the outer fairing screws hold the windshield in place, the windshield may fall to the floor if not removed.

6. Remove the Windshield.

#### Installing Mirrors

1. See Figure 1. Place template on inside of fairing as shown to locate mounting holes for mirror.
2. Begin by drilling a 1/8 inch pilot hole at each location marked on the template. For the center hole (2) where the 3/8 inch threaded stud passes through the fairing use a 13/32 inch diameter twist drill to drill the hole to its final size. For the alignment hole (1), use a 7/32 inch diameter twist drill to drill the hole to the final size.

#### NOTE

The flange nut is a self locking nut and must not be tightened more than 30 **in-lbs** (3.4 Nm).

3. See Figure 3. Place mirror (2) in position and install backing plate (4) with the raised post (B) (with the L and

R marking) toward the nut surface. Install the flange nut (6) and tighten nut to 20-30 **in-lbs** (2.3-3.4 Nm).

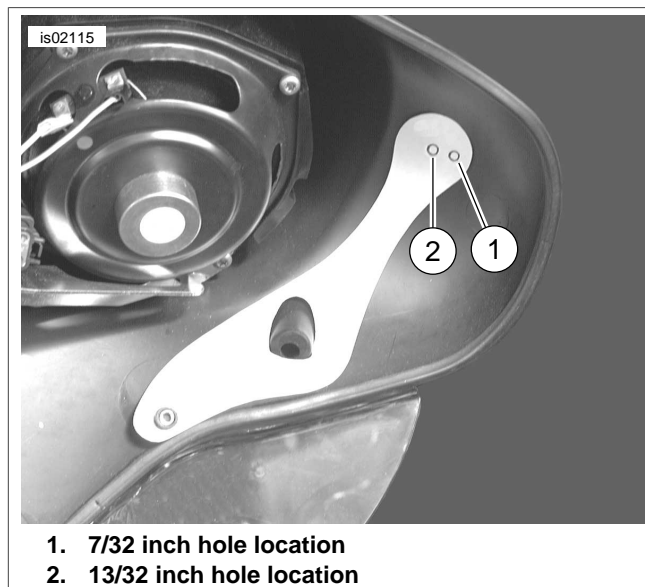

Figure 1. Positioning Template

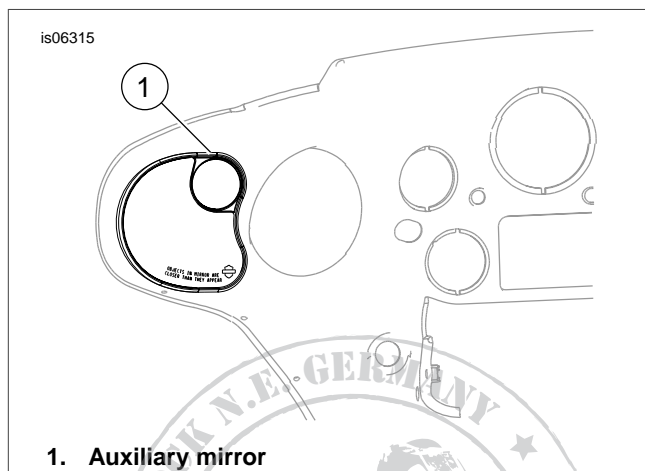

Figure 2. Orientation of Auxiliary Mirror

4. See Figure 2. Position the mirror so the round auxiliary mirror is in the upper inside corner position.
5. Repeat for right side.

#### Reinstalling Outer Fairing

1. Place the windshield in position on the inner fairing aligning the slots with the threaded inserts.
2. Place the fairing (with headlamp assembly) on the motorcycle installing the wire connector at the back of the headlamp assembly.

3. Using a T-27 TORX drive head, start the three outer fairing screws (with flat washers) just below the windshield.
4. Moving to the inner fairing side, use a T-27 TORX drive head to start the two fairing screws just above the wind deflectors on both the left and right side.
5. Turn the handlebar to the left and reaching in below the fairing cap, start the next fairing screw. Turn the handlebar to the right and start the fairing screw on the opposite side.
6. Alternately tighten the four fairing screws on the inner fairing side to 45-55 **in-lbs** (5.1-6.2 Nm).
7. Moving to the front of the vehicle, tighten the outer fairing screws below the windshield to 10-13 **in-lbs** (1.1-1.5 Nm).

**NOTE**

*Remove Caution decal from mirror before operating vehicle.*

**SERVICE PARTS**

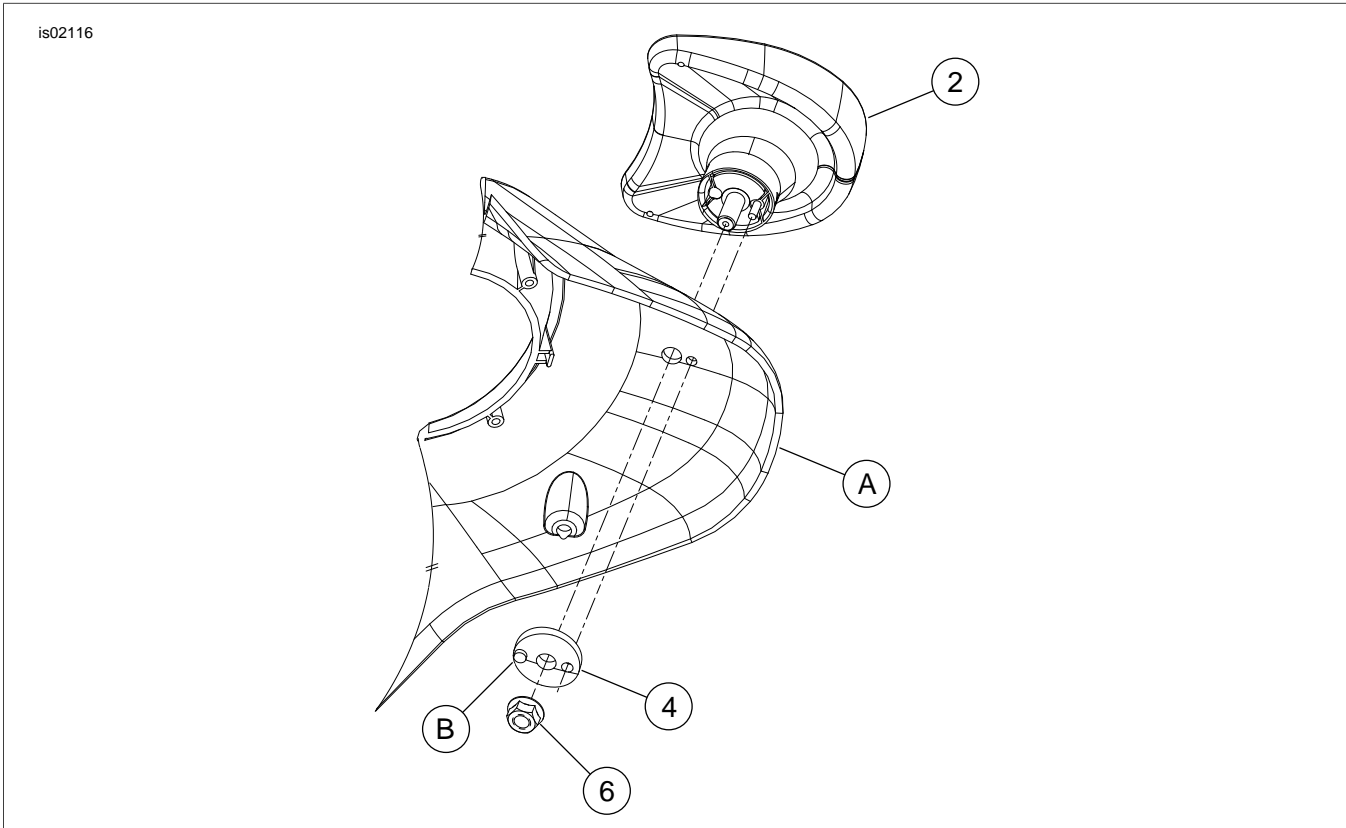

**Figure 3. Service Parts: Fairing Mount Mirrors**

**Table 1. Service Parts Table**

Item	Description (Quantity)	Part Number
1	Assembly, mirror, right (not shown)	91974-98B
	Assembly, mirror, chrome, right (not shown)	56000013
	Assembly, mirror, split vision, right (not shown)	Not Sold Separately
2	Assembly, mirror, left	91955-98B
	Assembly, mirror, chrome, left	56000014
	Assembly, mirror, split vision, left	Not Sold Separately
3	Template (not shown)	Not Sold Separately
4	Backing plate, left	53600-06
5	Backing plate, right (not shown)	53604-06
6	Nut (2)	7687
<b>Items mentioned in text, but not included in kit:</b>		
A	Fairing, left	
B	Plastic backing plate raised post	