



INSTRUCTIONS

-J00846

REV. 3-17-98

Kit Number 91843-97

SUPPLEMENTARY 12 VOLT POWER SOURCE

General

This kit fits 1994 and later carbureted FLHR, FLHT, and FLT (except FLHRC, Road King Classic) models. There are no service parts for this kit.

Installation

NOTE

This power source can be mounted on either side cover of the motorcycle, except on models with cruise control, which must have the power source mounted on the right side cover.

1. Remove seat and the side cover chosen for installation (see note above).

⚠ WARNING

To avoid accidental start-up of motorcycle, and possible personal injury, disconnect the battery cables (negative cable first) before performing any of the following procedures. If the positive cable should contact ground with the negative cable installed, the resulting sparks may cause a battery explosion resulting in personal injury.

2. Disconnect battery, negative cable first.
3. See Figure 1. A 7/8 inch diameter hole needs to be drilled in the top of the side cover to mount the power source. It is important that the hole is properly located as follows, **before cutting**:
 - a. Cut out template on page 3. Line the template up on the outside top of the cover using the top and rear cover edges as guides as shown in the illustration. Tape the template in place.
 - b. After the template is in place, locate the appropriate hole on the template that matches the applicable year and side cover. Check to be sure that the entire hole area is on the flat top surface of the cover. No part of the hole should extend onto the sharply curved edge of the cover.
4. Carefully drill a 7/8 inch diameter hole at the location marked on the template. Drill from the outside of the cover to the inside.
5. See Figure 2. Unscrew outer sleeve of socket assembly (1) from socket body. Place the socket body into the cover hole and secure the socket in place by screwing

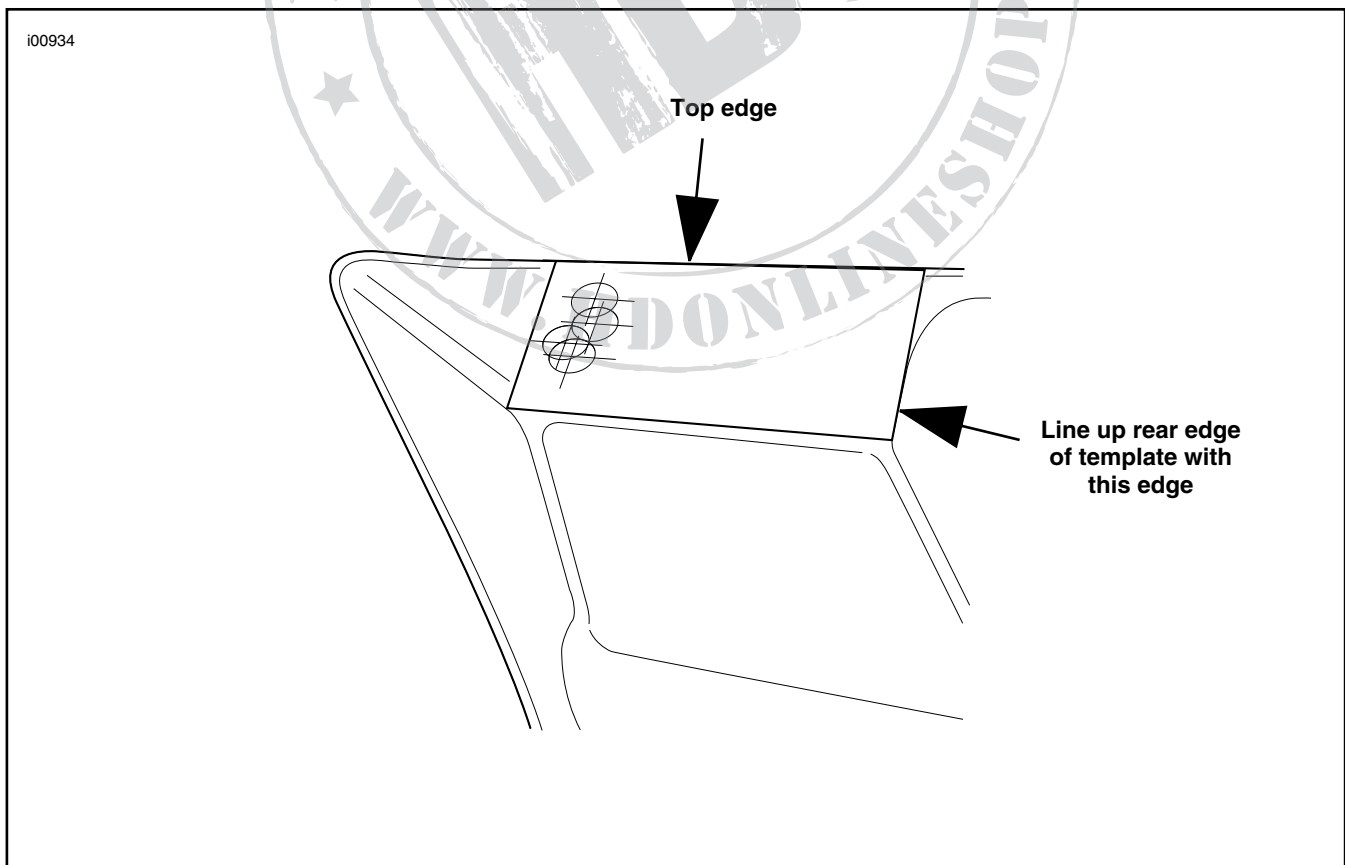

Figure 1 (left side cover shown)

back on the outer sleeve of the socket assembly from the inside of the side cover.

- See Figure 2. Connect the two spade terminals on the harness to the spades on the socket. Make sure the black wire (longer wire) is connected to the outer spade on the outer cover, and the orange wire (shorter wire) is connected to the inner spade in the center of the socket assembly.
- Plug the harness connector into the accessory plug under the seat.

NOTE

An accessory "Y" connector (Part No. 70264-94) is available from your dealer and allows you to connect more than one accessory into the accessory circuit.

⚠ WARNING

Always connect the positive battery cable first. If the positive cable should contact ground with the negative cable installed, the resulting sparks may cause a battery explosion resulting in personal injury.

- Reconnect battery, positive cable first.
- Install seat.

⚠ WARNING

After installing seat, pull upward on front of seat to be sure it is locked in position. If seat is loose, it could shift position during vehicle operation and startle the rider, causing loss of control and personal injury.

NOTE

The accessory circuit is a 15 Amp circuit. Check the rating of any accessories used with this power supply, and do not exceed the 15 Amp rating.

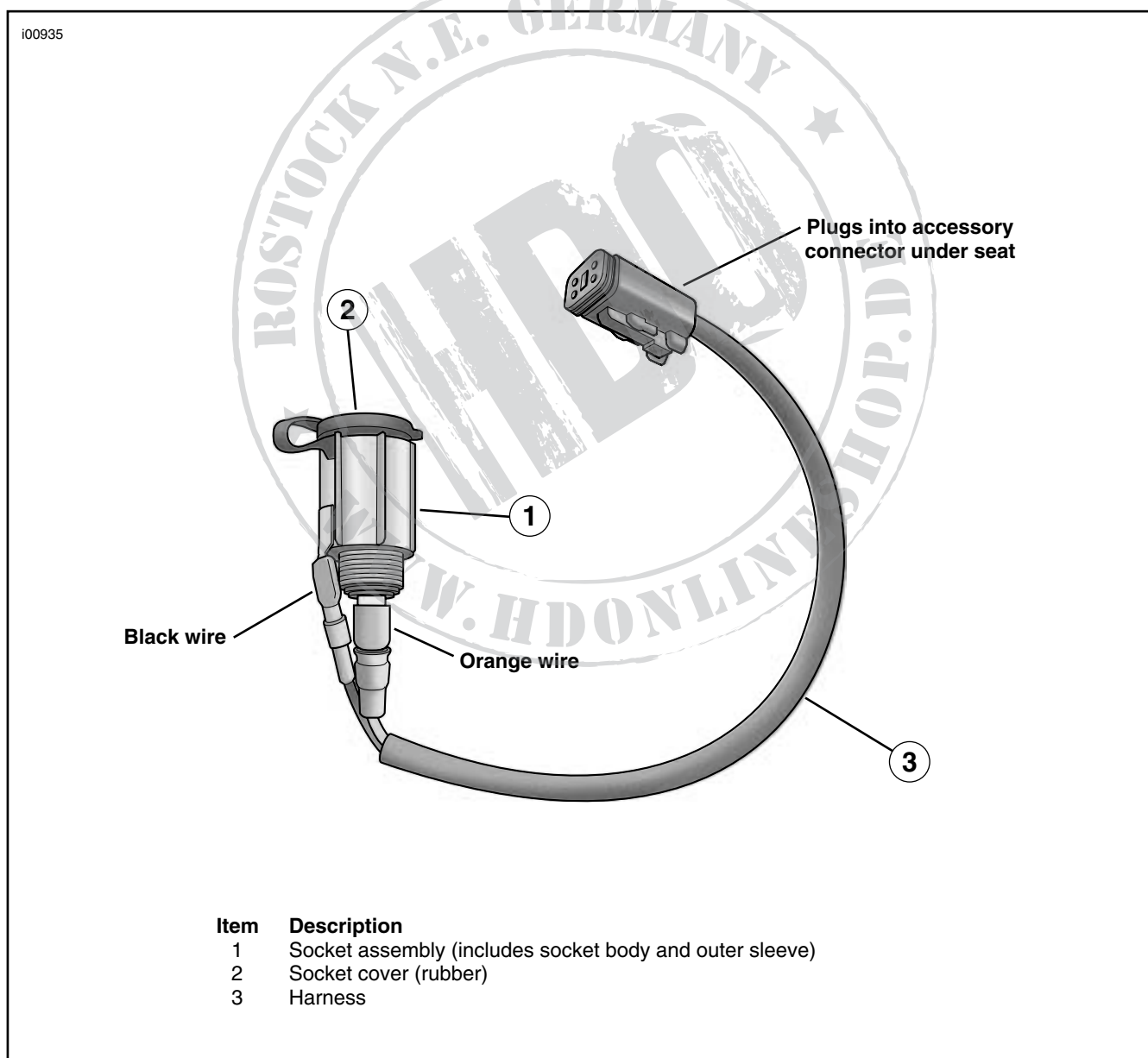

Figure 2

NOTE
These marks should measure exactly 1 inch in each direction. Please measure to verify that this template is the correct size.

