



# INSTRUCTIONS

-J04798

2008-06-19

## SADDLEBAG FILLER STRIP KITS

### GENERAL

#### Kit Number

91422-09, 91614-09XXX, 91670-09, 91741-09XXX

#### Models

For model fitment information, see the P&A Retail Catalog or the Parts and Accessories section of [www.harley-davidson.com](http://www.harley-davidson.com) (English only).

#### ▲ WARNING

The rider's safety depends upon the correct installation of this kit. Use the appropriate service manual procedures. If the procedure is not within your capabilities or you do not have the correct tools, have a Harley-Davidson dealer perform the installation. Improper installation of this kit could result in death or serious injury. (00333a)

#### NOTE

This instruction sheet references Service Manual information. A Service Manual for your model motorcycle is required for this installation and is available from a Harley-Davidson Dealer.

#### Kit Contents

See Figure 3 and Table 1.

### INSTALLATION

1. Remove the saddlebags following the instructions in the service manual.
2. Remove bottom exhaust mounting bolt and discard.
3. See Figure 1. For solid filler strips align as shown in Figure 1. See Figure 2. For slotted version align as shown in Figure 2 after assembling Nostalgic saddlebag rails.
4. Insert screw (1) and washer (2) into bottom mounting hole in top bracket. Start flange nut (3) onto back side of screw and tighten finger tight.
5. Figure 1. **Solid Filler Strips:** Feed screw (4) through bottom exhaust mounting bracket on the saddlebag support for solid filler strips, note screw orientation. Figure 2. **Slotted Filler Strips:** For slotted version, when used with Nostalgic Saddlebag Rails, reuse the bottom mounting hardware supplied with the rails.

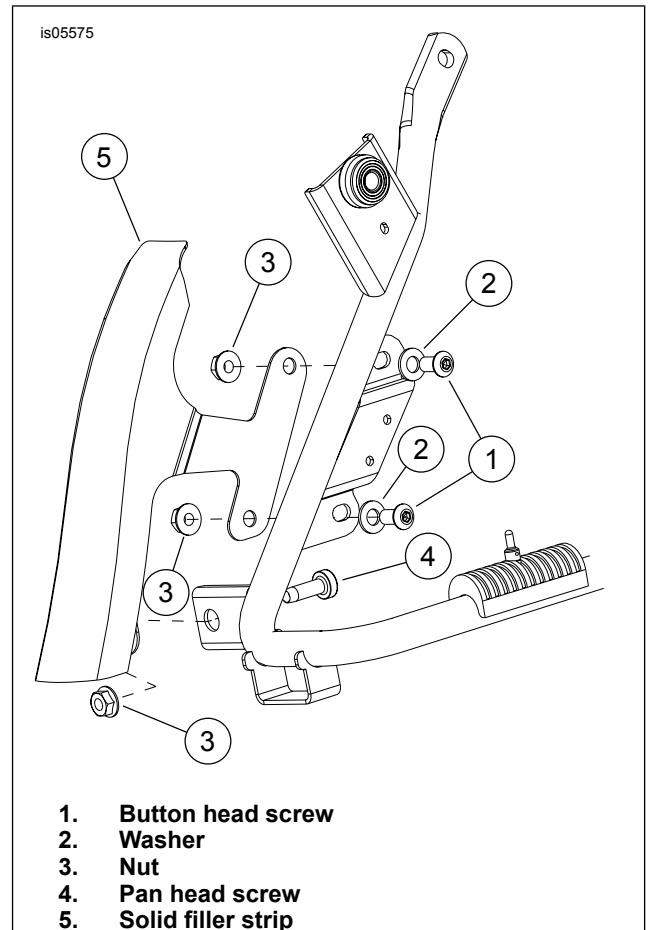

Figure 1. Solid Filler Strip Installation

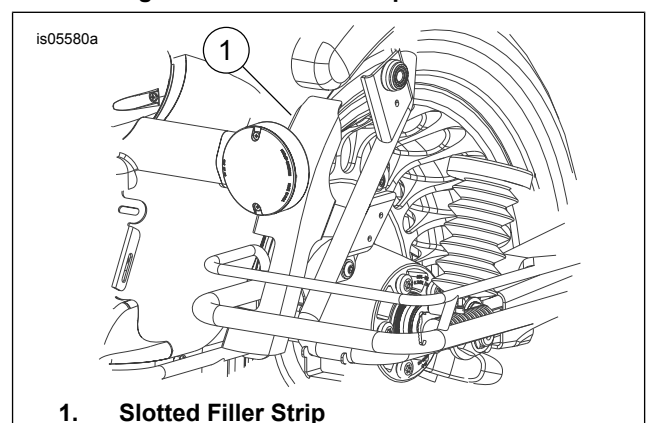
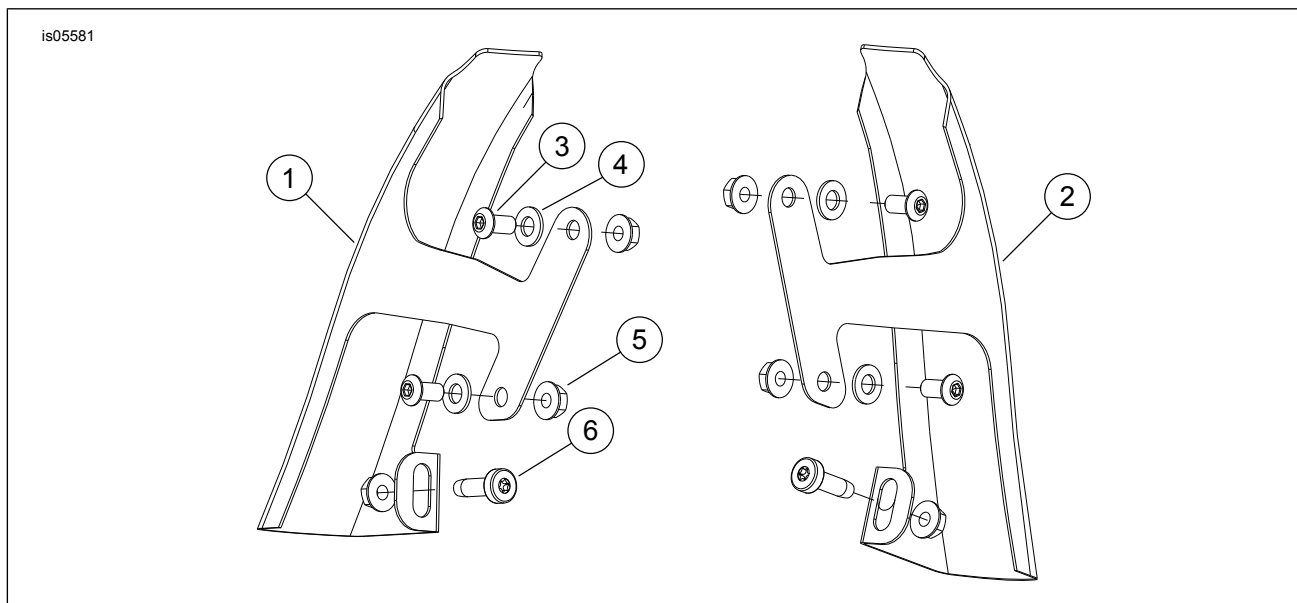

Figure 2. Slotted Filler Strip

6. Align fender mounting bracket and exhaust mounting, continuing to feed screw through until it protrudes through the bottom filler strip mounting slot.
7. See Figure 1. Start flange locking nut (3) onto screw and tighten until finger tight.

8. Insert final mounting screw (1) into the top mounting hole of the top mount bracket and tighten finger tight.
9. Adjust filler strip to desired location and tighten all screws to 20.3–27.1 N·m (15–20 ft-lbs).
10. Repeat Steps 2 through 9 for opposite side.

## SERVICE PARTS



**Figure 3. Service Parts: Saddlebag Filler Strips**

**Table 1. Service Parts Table**

| Kit   | Item | Description (Quantity)           | Part Number |
|---|------|----------------------------------|-------------|
| Kit 91422-09  | 1    | Filler strip, left               | 91449-09    |
| Solid Chrome  | 2    | Filler strip, right              | 91451-09    |
| Kit 91670-09  | 1    | Filler strip, left               | 91749-09    |
| Slotted Chrome  | 2    | Filler strip, right              | 91769-09    |
| Common Hardware   |      |                                  |             |
|   | 3    | Hex socket button head screw (4) | 3540        |
|   | 4    | Washer, type A (4)               | 6702        |
|   | 5    | Flange lock nut (6)              | 7531        |
|   | 6    | TORX® pan head tapping screw (2) | 3648        |
| <b>Service parts are not available for Colormatch kits.</b> |      |                                  |             |