



INSTRUCTIONS

-J04798

REV. 2008-06-19

SADDLEBAG FILLER STRIP KITS

GENERAL

Kit Number

91422-09, 91614-09XXX, 91670-09, 91741-09XXX

Models

For model fitment information, see the P&A Retail Catalog or the Parts and Accessories section of www.harley-davidson.com (English only).

WARNING

The rider's safety depends upon the correct installation of this kit. Use the appropriate service manual procedures. If the procedure is not within your capabilities or you do not have the correct tools, have a Harley-Davidson dealer perform the installation. Improper installation of this kit could result in death or serious injury. (00333a)

NOTE

This instruction sheet references Service Manual information. A Service Manual for your model motorcycle is required for this installation and is available from a Harley-Davidson Dealer.

Kit Contents

See Figure 3 and Table 1.

INSTALLATION

1. Remove the saddlebags following the instructions in the service manual.
2. Remove bottom exhaust mounting bolt and discard.
3. Figure 1. For solid filler strips align as shown in Figure 1. Figure 2. For slotted version align as shown in Figure 2 after assembling Nostalgic saddlebag rails.
4. Insert screw (1) and washer (2) into bottom mounting hole in top bracket. Start flange nut (3) onto back side of screw and tighten finger tight.
5. Figure 1. **Solid Filler Strips:** Feed screw (4) through bottom exhaust mounting bracket on the saddlebag support for solid filler strips, note screw orientation. Figure 2. **Slotted Filler Strips:** For slotted version, when used with Nostalgic Saddlebag Rails, reuse the bottom mounting hardware supplied with the rails.

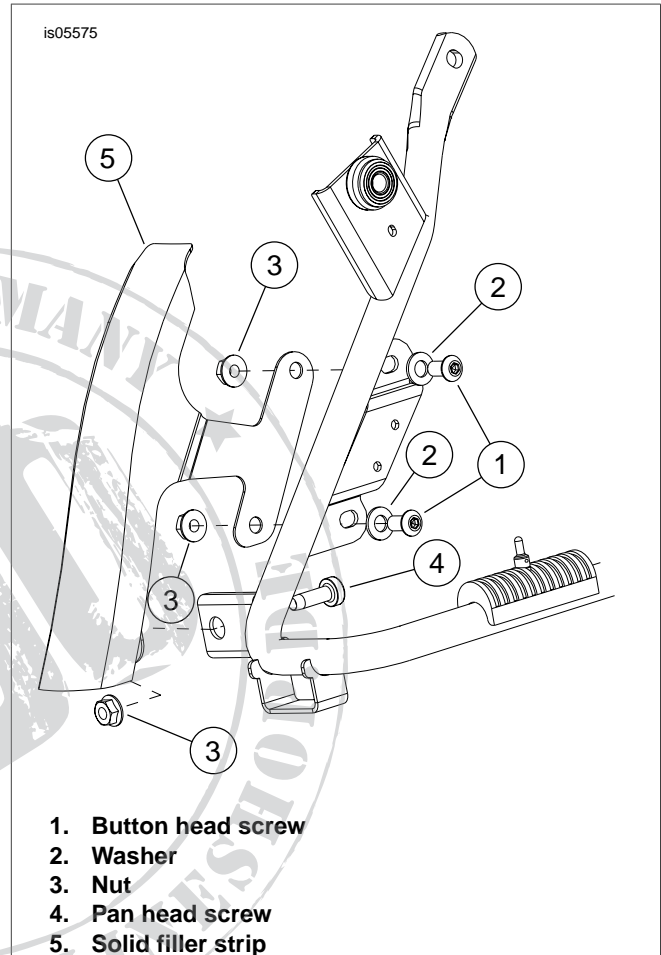

Figure 1. Solid Filler Strip Installation

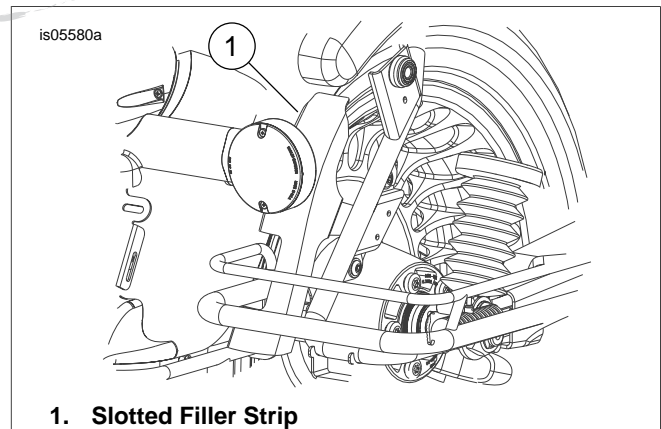

Figure 2. Slotted Filler Strip

6. Align fender mounting bracket and exhaust mounting, continuing to feed screw through until it protrudes through the bottom filler strip mounting slot.
7. Start flange locking nut (3) onto screw and tighten until finger tight.
8. Insert final mounting screw (1) into the top mounting hole of the top mount bracket and tighten finger tight.
9. Adjust filler strip to desired location and tighten all screws to 15-20 ft-lbs (20.3-27.1 Nm).
10. Repeat Steps 2 through 9 for opposite side.

SERVICE PARTS

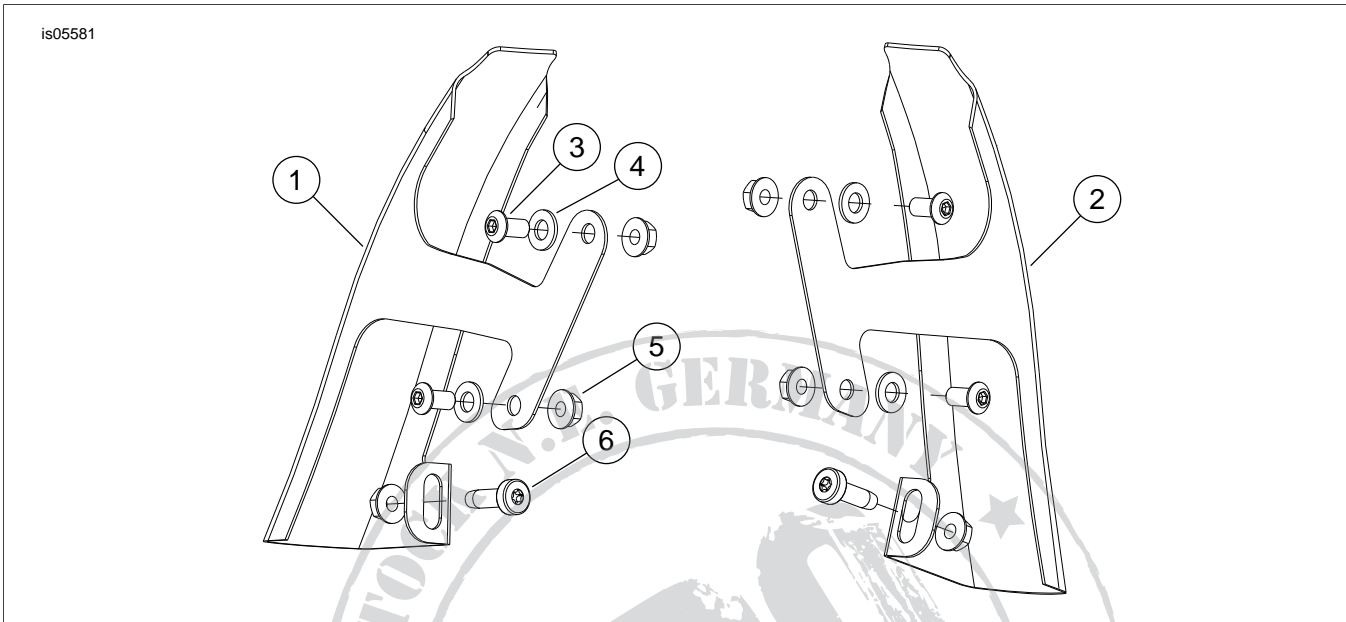

Figure 3. Service Parts: Saddlebag Filler Strips

Table 1. Service Parts Table

Kit	Item	Description (Quantity)	Part Number
Kit 91422-09 Solid Chrome	1	Filler strip, left	91449-09
	2	Filler strip, right	91451-09
Kit 91670-09 Slotted Chrome	1	Filler strip, left	91749-09
	2	Filler strip, right	91769-09
Common Hardware			
	3	Hex socket button head screw (4)	3540
	4	Washer, type A (4)	6702
	5	Flange lock nut (6)	7531
	6	TORX® pan head tapping screw (2)	3648
Service parts are not available for Colormatch kits.			