



# INSTRUCTIONS

-J03917

REV. 2006-06-01

## VRSC SADDLEBAG KITS

### GENERAL

#### Kit Number

91136-07, 91401-06, and 91441-06

#### Models

These kits fit 2006 and later VRSC models equipped with saddlebag mounting hardware kits.

#### Kit Contents

See Figure 4 and Table 1.

#### **⚠ WARNING**

Do not exceed saddlebag weight capacity. Put equal weight in each bag. Too much weight in saddlebags can cause loss of control, which could result in death or serious injury. (00383a)

#### NOTE

Maximum saddlebag weight capacity is 3.2 Kg (7 lbs).

#### Saddlebag Mounting Hardware Kit

Refer to the instructions supplied with the hardware kit to install the Saddlebag Mounting Hardware.

### INSTALLATION

#### Attach Saddlebag

1. See Figure 1. Prior to attaching saddlebags, ensure that the locking pin (1) is tightened to 5.6 Nm (50 in-lbs).
2. Hang hooks (2) on saddlebag over the release/attach assembly ensuring that the isolator pad (3) locates between the hooks.

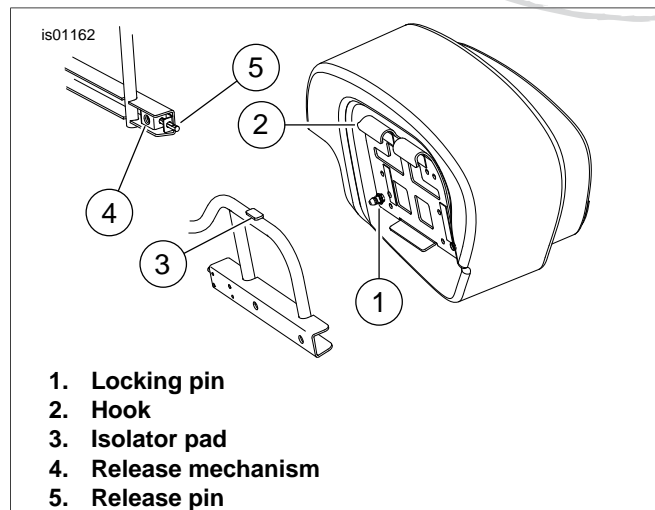

Figure 1. Saddlebag Mounting Hardware

3. Ensure that the locking pin (1) locates in the hole of the release mechanism (4).
  - a. Push in on the bottom of the saddlebag until it locks into place. If it will not lock, remove saddlebag. Loosen the locking pin nut, back out pin one turn, and retighten.
  - b. Repeat Steps 1-3, as necessary, until saddlebag locks properly into place.

#### Release Saddlebag

#### **⚠ WARNING**

Do not operate motorcycle without saddlebags attached unless the saddlebag attach/release rack is also removed. The rack obscures stock reflectors. Low visibility of rider can result in death or serious injury. (00425c)

See Figure 1. Press in on the release pin (5), tilt the bottom of the saddlebag outward, and lift it up and away.

#### Install Reflectors

#### **⚠ WARNING**

Federal Motor Vehicle Safety Standard (FMVSS) 108 requires motorcycles to be equipped with rear and side reflectors. Be sure rear and side reflectors are properly mounted. Poor visibility of rider to other motorists can result in death or serious injury. (00336b)

#### Adhesive Reflectors (Kits 91401-06 and 91441-06)

#### Domestic models:

1. See Figure 2. Position reflector on flat panel on side of saddlebag.

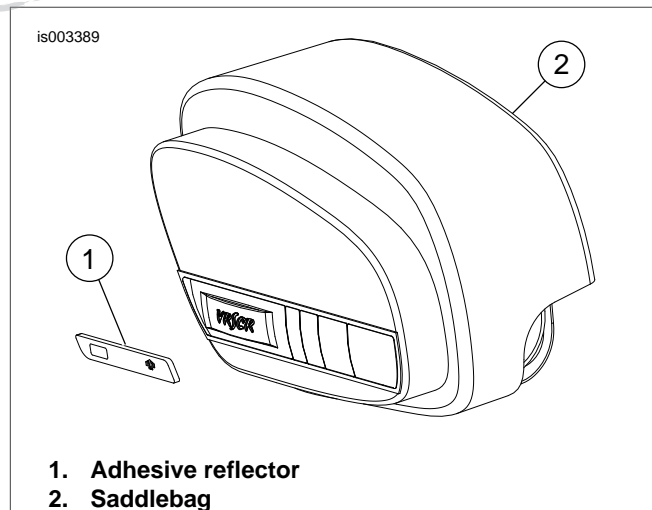

Figure 2. Adhesive Reflectors

- Using soapy water, clean the surface where reflector will be installed.
- Allow the surface to dry completely before continuing.
- Remove adhesive backing from reflector and install on saddlebag.
- While holding from behind, apply pressure to entire reflector to promote adhesion.
- Repeat for opposite side.

*HDI models:* Side reflector is not required and there is no amber reflector provided in this kit. For these models, discard the red reflector.

#### Mounted Reflectors (Kit 91136-07)

- See Figure 3. Position reflector mount on lower right corner of saddlebag.
- Mark holes on saddlebag with pen (or other appropriate tool).

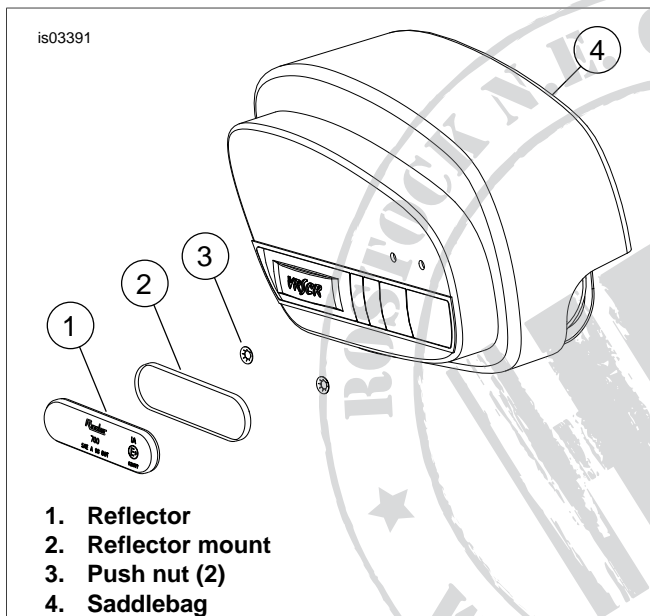

Figure 3. Mounted Reflectors

- Using soapy water, clean the surface where reflector will be installed.
- Allow the surface to dry completely before continuing.
- Using appropriate tool, make two 4.76 mm (3/16 in.) holes in saddlebag.
- Install reflector mount on saddlebag using two push nuts.
- Remove adhesive backing from reflector and install on mount.
- Let the adhesive cure for at least 24 hours at no less than 16°C (60°F).
- Repeat for opposite side.

#### Install Opposite Saddlebag

After completing the installation for one side of the motorcycle, repeat the same tasks to install the saddlebag on the opposite side.

### SADDLEBAG OPERATION AND CARE

#### Opening Saddlebag

To open saddlebag, first disengage the snap or hook and loop at the rear of the saddlebag, then pull the tabs of the two zippers to the front of the saddlebag and lift the lid.

#### Closing Saddlebag

To close the saddlebag, pull the tabs of the two zippers towards the rear of the saddlebag, and engage the snap or hook and loop at the rear.

#### Care of Cloth

Avoid exposure to transmission fluid.

#### Care of Snaps

The snaps on the front and rear of the saddlebags will periodically need to be oiled.

Apply a drop of motor oil into the female side of the snap, being careful not to get any oil on the cloth.

Repeat every 30 to 60 days, or whenever snaps become noticeably more difficult to engage or disengage.

# SERVICE PARTS

is03392



**Figure 4. Service Parts: VRSC Saddlebag Kits**

**Table 1. Service Parts: VRSC Saddlebag Kits**

Kit	Item	Description (Quantity)	Part Number
91401-06	1	Saddlebag, right	91206-06B
	2	Saddlebag, left	91205-06B
	3	Rubber insulator pads	91214-06
	4	Reflector, right (adhesive)	59288-92
	5	Reflector, left (adhesive)	59287-92
91441-06	1	Saddlebag, right	91331-06
	2	Saddlebag, left	91332-06
	3	Rubber insulator pads	91214-06
	4	Reflector, right (adhesive)	59288-92
	5	Reflector, left (adhesive)	59287-92
91136-07	1	Saddlebag, right	91152-07
	2	Saddlebag, left	91158-07
	3	Rubber insulator pads	91214-06
	6	Reflector, mounted (2)	59173-00
	7	Mount, reflector (2)	Not Sold Separately
	8	Push nuts, reflector (4)	8126A
	9	Reflector Kit (2) (includes Items 6, 7, 8)	59480-04