



# INSTRUCTIONS

-J04532

REV. 2007-10-15

## XL SYNTHETIC LEATHER SADDLEBAG KIT

### GENERAL

#### Kit Number

90330-08

#### Models

For model fitment information, please see the P&A Retail Catalog or the Parts and Accessories section of [www.harley-davidson.com](http://www.harley-davidson.com) (English only).

#### Additional Parts Required

This kit requires the separate purchase of a Turn Signal Relocation Kit (68732-02A for domestic and 68733-02A for international).

#### WARNING

Do not exceed saddlebag weight capacity. Put equal weight in each bag. Too much weight in saddlebags can cause loss of control, which could result in death or serious injury. (00383a)

#### NOTE

Maximum saddlebag weight is 7 pounds (3.2 Kg) for each bag.

#### WARNING

The rider's safety depends upon the correct installation of this kit. Use the appropriate service manual procedures. If the procedure is not within your capabilities or you do not have the correct tools, have a Harley-Davidson dealer perform the installation. Improper installation of this kit could result in death or serious injury. (00333a)

#### NOTE

This instruction sheet references Service Manual information. A Service Manual for your model motorcycle is required for this installation and is available from a Harley-Davidson Dealer.

#### Kit Contents

See Figure 2 and Table 1.

### INSTALLATION

#### WARNING

To prevent accidental vehicle start-up, which could cause death or serious injury, remove main fuse before proceeding. (00251b)

1. Refer to the Owner's Manual and remove the main fuse.
2. Properly support motorcycle under frame with stand or suitable blocking to prepare for addition of saddlebags.

3. See Figure 1. Remove and discard front and rear button head screws (1), two locknuts (2) and under fender clip nuts (3) from the left and right rear fender support covers (4).

#### NOTE

Rear turn signals must be relocated to new turn-signal bar on the rear license plate bracket.

4. Follow the instructions provided with the Turn Signal Relocation Kit to relocate the rear turn signals.

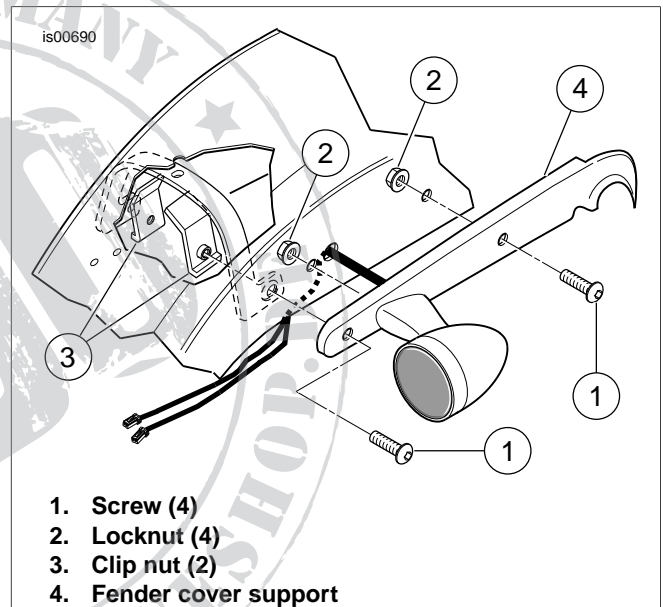

Figure 1. Rear Fender Support Removal

5. See Figure 2. From the underside of the fender, install two bolts (2) from kit through the fender and into the fender support (A) and cover (B), where the two button head screws were previously removed.
6. Install the short spacer (4) onto the front bolt (short end toward saddlebag) and the long spacer (5) onto the rear bolt (short end toward saddlebag).
7. Install a washer (10) onto each bolt over the spacers.
8. Slide the saddlebag (1) onto the bolts until spacers are seated onto the saddlebag bracket.
9. Thread flange locknuts (3) to bolts on the inside of the saddlebag. Tighten both flange locknuts to 24-27 ft-lbs (33-37 Nm).
10. Install a thread protector cap (6) onto each of the bolt ends.
11. Refer to the Owner's Manual and install the main fuse.

## Install Reflectors

### WARNING

**Federal Motor Vehicle Safety Standard (FMVSS) 108 requires motorcycles to be equipped with rear and side reflectors. Be sure rear and side reflectors are properly mounted. Poor visibility of rider to other motorists can result in death or serious injury. (00336b)**

1. Measure approximately 1-1/2 in. (38 mm) from the bottom edge of the saddlebag. Orient the reflector horizontally and carefully center the reflector mount between the straps of bags with straps or locate it at the rearward portion of bags without straps.
2. See Figure 2. Position reflector mount (13) on saddlebag.
3. Mark holes on saddlebag with pen (or other appropriate tool).
4. Using soapy water, clean the surface where reflector will be installed.
5. Allow the surface to dry completely before continuing.
6. Using appropriate tool, make two 3/16 in. holes in saddlebag.
7. Install reflector mount (13) on saddlebag using two push nuts (14).
8. Remove backing from adhesive on reflector (12) and install on mount (13).
9. Let the adhesive cure for at least 24 hours at no less than 60°F (16°C).



# SERVICE PARTS

is04963

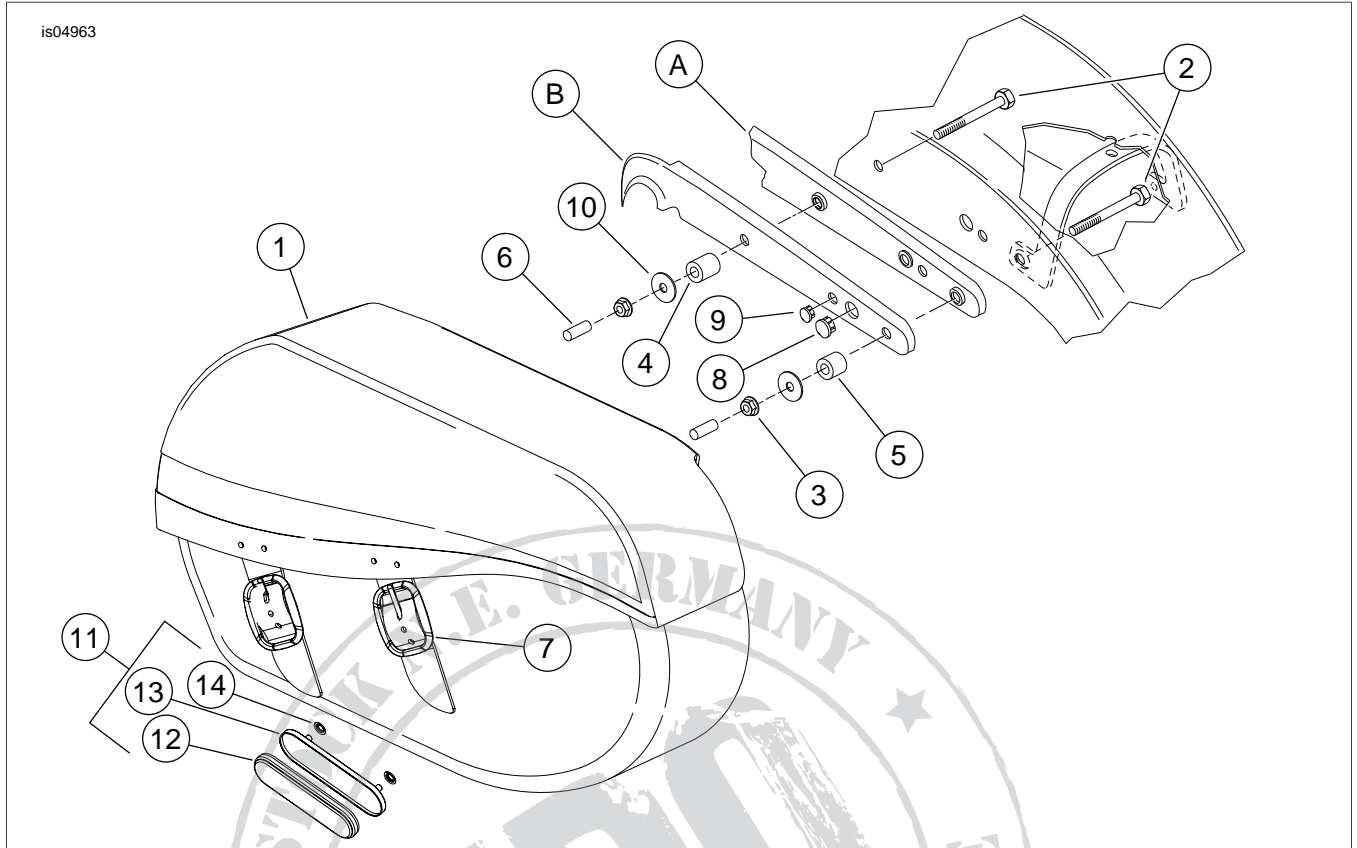

**Figure 2. Service Parts for XL Synthetic Leather Saddlebag Kit (Left Side Shown)**

**Table 1. Service Parts Table**

Item	Description (Quantity)	Part Number
1	Saddlebag, left	90334-08
	Saddlebag, right	90344-08
2	Capscrew (4)	4375
3	Nut, flange (4)	7531
4	Spacer, short (2)	11833
5	Spacer, long (2)	11834
6	Cap, thread protector (4)	89571-97
7	Chrome buckle with male disconnect clip	90497-08
8	Plug, small (2)	53377-04
9	Plug, Large (2)	68446-00
10	Washer	6229W
11	Kit, reflector (2)	59480-04
12	• Reflector	59173-00
13	• Mount, reflector	Not Sold Separately
14	• Push nuts (2)	8126A
<b>Items mentioned in text, but not included in kit:</b>		
A	Fender strut	
B	Cover, fender strut	