



INSTRUCTIONS

-J02153

REV. 2004-11-23

SADDLEBAG GUARDRAIL TRIM

GENERAL

Kit Number

90206-02, 90214-05

Models

This kit fits 1993 and later Electra Glide® Classic and Ultra Classic, 1998 and later Road Glide®, 1993-1996 Tour Glide® Ultra Classic, and 1993 and later Electra Glide® Standard with Chrome Saddlebag Guard Kit, Part Number 90839-93A.

Additional Parts Required

⚠ WARNING

The rider's safety depends upon the correct installation of this kit. Use the appropriate service manual procedures. If the procedure is not within your capabilities or you do not have the correct tools, have a Harley-Davidson dealer perform the installation. Improper installation of this kit could result in death or serious injury. (00333a)

NOTE

This instruction sheet references Service Manual information. A Service Manual for your model motorcycle is required for this installation and is available from a Harley-Davidson Dealer.

Kit Contents

See Figure 1 and Table 1.

INSTALLATION

1. Remove the saddlebags according to service-manual instructions.
 2. See the Service Parts illustration. Remove the screws fastening the stock upper-front guardrail mounts to the guard rail. Discard the stock upper-front guardrail mounts.
 3. Fasten the new front brackets (2, 5) where the stock upper-front guardrail mounts were removed in step 2. Tighten the screws to 72-120 **in-lbs** (8.1-13.5 Nm).
 4. Loosely fasten the rear-inside brackets (9) to the guardrail rear trim (12) using screws (4), flat washers (10), and keps nuts (11) as shown.
 5. Remove the inner and outer stock guardrail brackets. Discard the stock inner brackets.
 6. Loosely fasten the guardrail side trim (1, 8) to the front brackets (2, 5).
 7. Remove the stock screws fastening the stock upper and lower guardrail tabs to the vehicle. Save the screws for installation.
- NOTE**
For steps 8 and 9, see the Service Parts illustration for exact orientation of the rear-trim flange relative to the side-trim flange, and rear-inside bracket orientation relative to the guardrail tabs.
8. Position the rear-inside brackets (9), with rear trim loosely attached, on the outboard side of the stock upper and lower guardrail tabs. Loosely fasten the rear inside brackets (9) to the guardrail tabs and vehicle using the screws removed in step 7.
 9. Loosely fasten the side- and rear-trim flanges between the stock outer-guardrail bracket and the new inner guardrail brackets (7, 13) using screws (6) and wave washers (3).
 10. Align all installed components and use the Allen wrench (14) from this kit to tighten the fasteners.
 - Tighten screws at the upper and lower guardrail tabs to 15-20 ft-lbs (20-27 Nm).
 - Tighten the fasteners from this kit (4, 6, 11) to 30-50 **in-lbs** (3.4-5.6 Nm).
 11. Install the saddlebags.

SERVICE PARTS

is01698

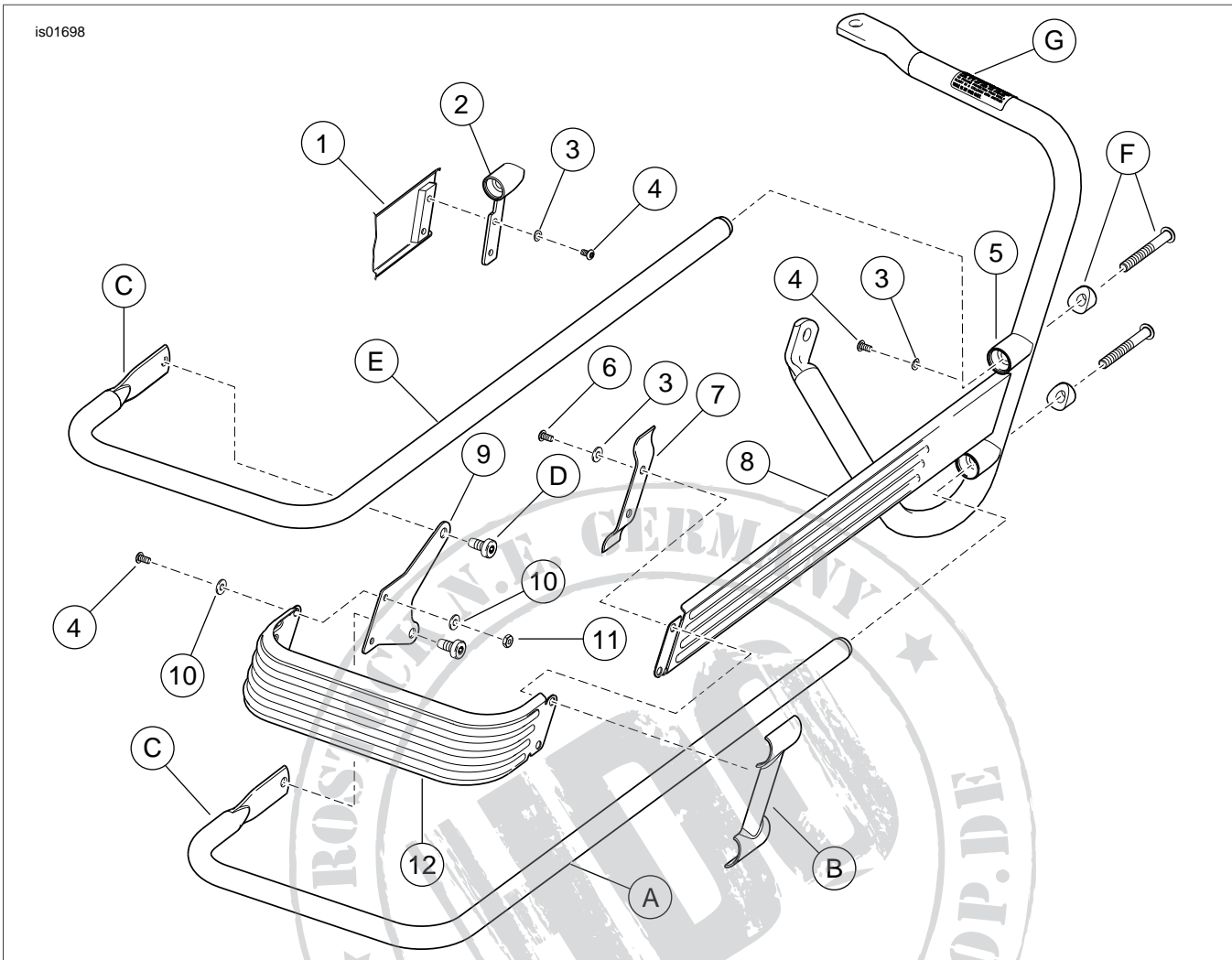

Figure 1. Service Parts: Saddlebag Guardrail Trim

Table 1. Service Parts Table

Item	Description (Quantity)	Part Number	Item	Description (Quantity)	Part Number
1	Guardrail side trim, left-hand	Not Sold Separately	12	Guardrail rear trim (2)	Not Sold Separately
2	Bracket, front left-hand	Not Sold Separately	13	Bracket, inner guardrail, left-hand (not shown)	Not Sold Separately
3	Wave washer, #10 (8)	6065	14	Allen wrench, 1/8-in.(not shown)	Not Sold Separately
4	Screw, 10-32 x .375-in., 1/8-in. hex drive, grade 5 (8)	Not Sold Separately	Stock Items:		
5	Bracket, front right-hand	Not Sold Separately	A	Lower guard rail	
6	Screw, 10-24 x .50-in., 1/8-in. hex drive, grade 5 (4)	Not Sold Separately	B	Outer guardrail bracket	
7	Bracket, inner guardrail right-hand	Not Sold Separately	C	Guardrail tab	
8	Guardrail side trim, right-hand	Not Sold Separately	D	Bolt	
9	Bracket, rear inside (2)	Not Sold Separately	E	Not Sold Separately	
10	Flat washer, #10 (8)	6716	F	Bolt and washer	
11	Keps nut, 10-32 (4)	7629	G	Guardrail	

NOTE: Items 2 and 5 replace stock upper front guardrail mounts.