



# INSTRUCTIONS

-J06251

2015-08-01

## SPORTSTER LEATHER SADDLEBAG KIT

### GENERAL

#### Kit Number

90201306, 90201329

#### Models

For model fitment information, see the P&A Retail Catalog or the Parts and Accessories section of [www.harley-davidson.com](http://www.harley-davidson.com) (English only).

#### Additional Parts and Tools Required

Separate purchase and installation of additional parts or accessories may be required for proper installation of this kit on your model motorcycle. See the P&A Retail Catalog or the Parts and Accessories section of [www.harley-davidson.com](http://www.harley-davidson.com) (English only) for a list of required parts or accessories for your model.

Proper installation of this kit also requires the following:

Loctite® Threadlocker and Sealant - Blue (99642-97)

Snap-On TT600-3 pick tool

Kent-Moore UltraTorch UT-100 or other suitable radiant heating device

#### ⚠ WARNING

**Do not exceed saddlebag weight capacity. Put equal weight in each bag. Too much weight in saddlebags can cause loss of control, which could result in death or serious injury. (00383a)**

#### NOTE

Maximum saddlebag weight is ten pounds (4.5 Kg) for each bag.

#### ⚠ WARNING

**The rider's safety depends upon the correct installation of this kit. Use the appropriate service manual procedures. If the procedure is not within your capabilities or you do not have the correct tools, have a Harley-Davidson dealer perform the installation. Improper installation of this kit could result in death or serious injury. (00333a)**

#### NOTE

*This instruction sheet references service manual information. A service manual for your model motorcycle is required for this installation and is available from a Harley-Davidson dealer.*

### Kit Contents

See Figure 3 and Table 1.

### Existing Equipment Removal and Installation

#### ⚠ WARNING

**To prevent accidental vehicle start-up, which could cause death or serious injury, disconnect negative (-) battery cable before proceeding. (00048a)**

1. Refer to the service manual and follow the instructions given to remove the seat, and disconnect the negative battery cable. Save seat mounting hardware for later use.
2. Properly support motorcycle under frame with stand or suitable blocking to prepare for addition of saddlebags. Support rear wheel to prevent it from falling when rear shock absorbers are disconnected in the following step.
3. See Figure 1. Disconnect the rear shock absorbers from the swing arm by removing bolt (1), washer (2) and nut (4) from the shock absorber (3). Repeat steps for the opposite side.
4. Carefully lower rear wheel enough to access the inside of the rear fender.

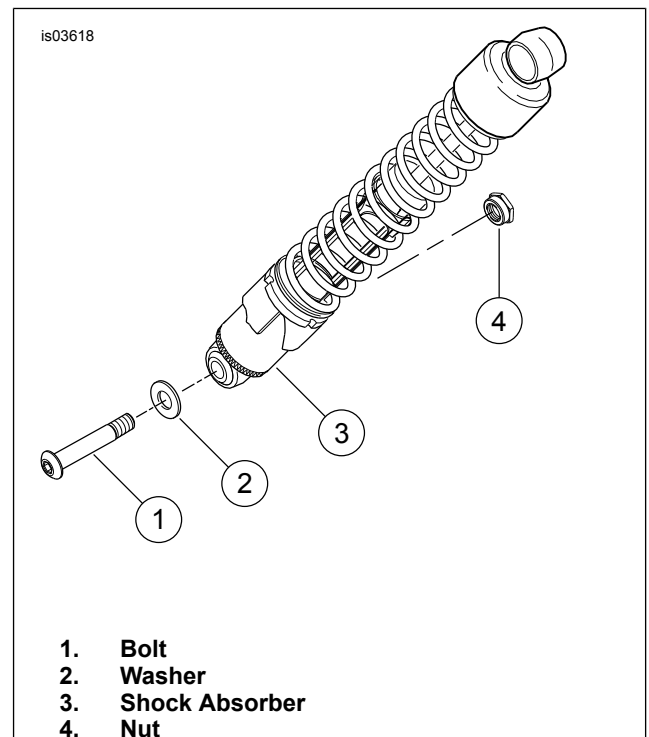

Figure 1. Rear Shock Absorber - Right Side Shown

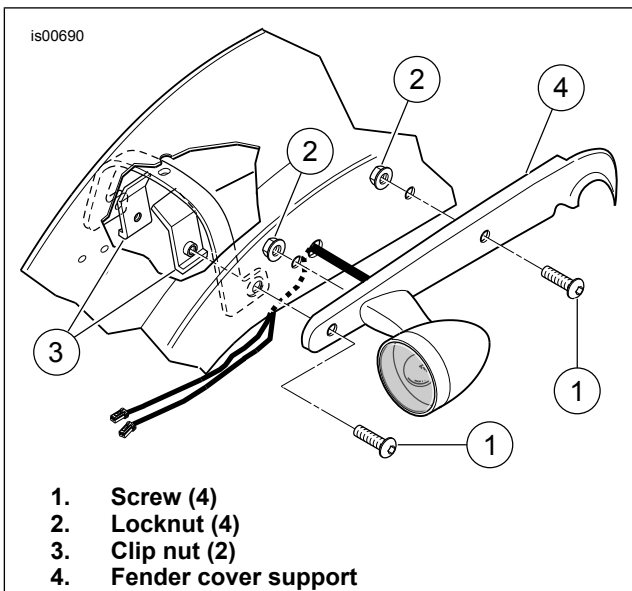

Figure 2. Rear Fender Support Removal

## Saddlebag Installation

1. See Figure 3. Remove the rear shock absorber bolt (Figure 1, Item 1). Position the 0.531 x 0.75 x 0.75 in spacer (7) and the front saddlebag bracket attachment hole over the rear shock absorber bolt location. Secure with the 1/2-13 x 4.00 in screw (5).
2. See Figure 3. Position the 0.385 x 0.75 x 0.75 in spacer (8) and the rear saddlebag attachment hole over the second hole on the rear of the fender, fender support cover and relocation pad. From the underside of the fender, insert a 5/16-18 x 3.75 in screw (6). Secure with locknut (9). Tighten locknut (9) to 32.5–36.6 N·m (24–27 ft-lbs).
3. Tighten the front screw (5) to 28.5–36.6 N·m (21–27 ft-lbs).
4. See Figure 3. Assemble an isolator washer (11) onto an isolator bushing (12). Place a screw (14) through the bushing.
5. Place the screw and bushing assembly into the top hole inside the saddlebag back.
6. See Figure 3. Push a saddlebag isolator (13) over bushing with cone shape toward saddlebag.

7. Place saddlebag in position on bracket. Insert the new screw (14) into the bracket. Do not tighten.
8. Repeat steps 4-7 for remaining holes. With all isolators in place, tighten screws to 10.8–13.6 N·m (96–120 in-lbs).
9. Repeat Steps 1-8 for the opposite saddlebag.
10. Raise rear wheel until the rear shock absorbers align with shock absorber mounting holes on the swingarm. Support the wheel to prevent it from falling during the following step.
11. See Figure 1. Attach rear shock absorber to swingarm by installing bolt (1), washer (2) and nut (4). Tighten bolt to 61.1–67.9 N·m (45–50 ft-lbs). Repeat steps for opposite side.

## Install Reflectors

### ⚠ WARNING

**Federal Motor Vehicle Safety Standard (FMVSS) 108 requires motorcycles to be equipped with rear and side reflectors. Be sure rear and side reflectors are properly mounted. Poor visibility of rider to other motorists can result in death or serious injury. (00336b)**

1. See Figure 3. Measure approximately 1-1/2 in (38 mm) from the bottom edge of the saddlebag. Align the reflector horizontally. Carefully center the reflector mount between the straps or at the rearward portion of bags without straps. Mark hole location.
2. Using appropriate tool, make two 3/16 in holes in saddlebag.
3. Install reflector mount (3) on saddlebag using two pushnuts (2).
4. Remove adhesive backing from reflector (4). Install on mount.
5. Repeat steps 1-4 for the opposite saddlebag.

## SEAT INSTALLATION

### ⚠ WARNING

**After installing seat, pull upward on seat to be sure it is locked in position. While riding, a loose seat can shift causing loss of control, which could result in death or serious injury. (00070b)**

1. See service manual instruction to install the seat.

# SERVICE PARTS

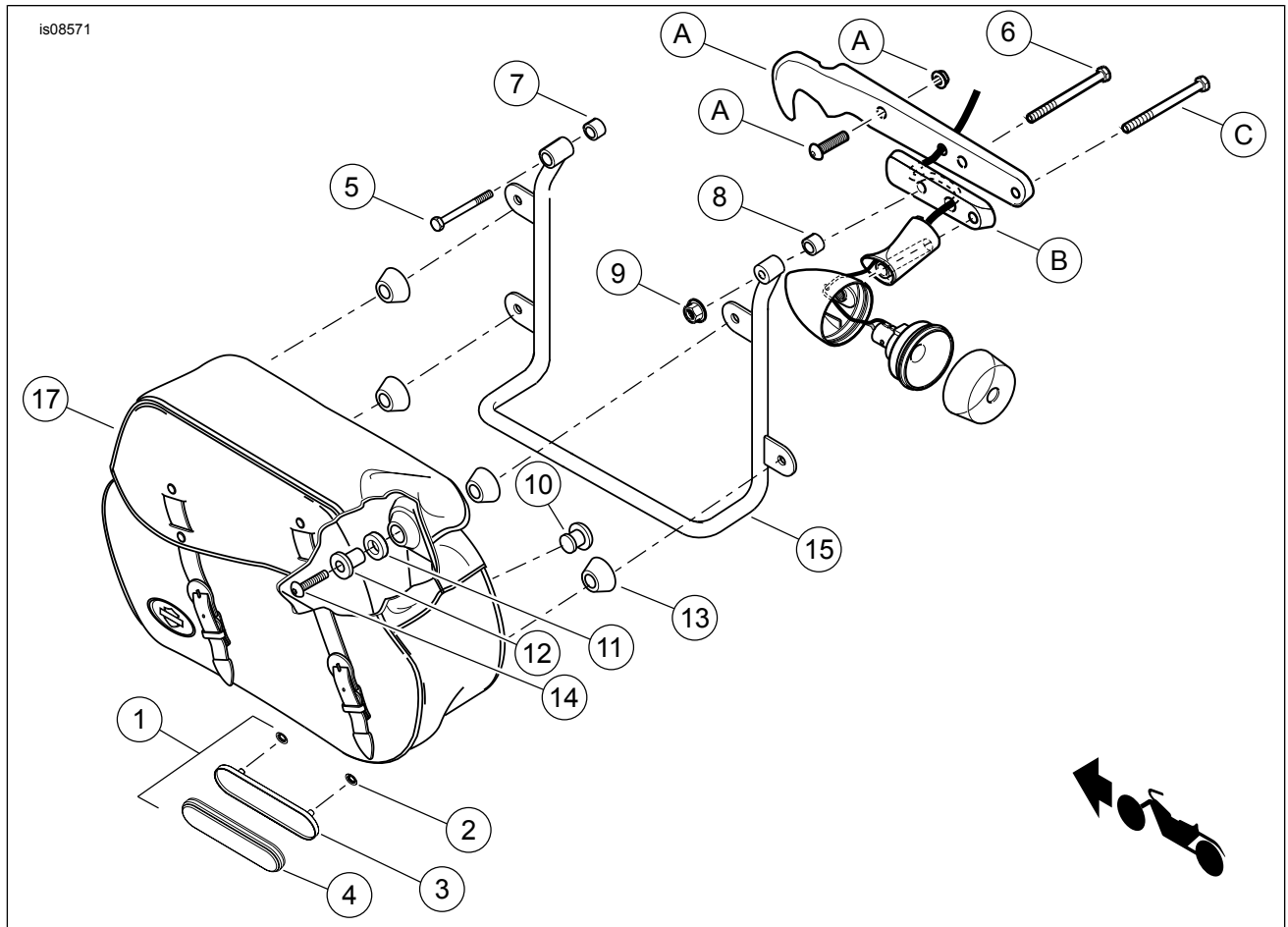

**Figure 3. Service Parts: Leather Saddlebag Kit**

**Table 1. Service Parts: Leather Saddlebag Kit**

Item	Description (Quantity)	Part Number
1	Reflector Kit (includes items 2-4)	59480-04A
2	• Pushnut (2)	8126A
3	• Mount, reflector	Not Sold Separately
4	• Reflector, red	Not Sold Separately
5	Screw, hex cap 1/2-13 x 4.00 (2)	54718-06A
6	Screw, hex cap 5/16-18 x 3.75 (2)	4298
7	Spacer, 0.531 x 0.75 x 0.75 (2)	12400112
8	Spacer, 0.375 x 0.75 x 0.75 (2)	12400113
9	Locknut, 5/16-18 (2)	7531
10	Bumper (4)	62123-66A
11	Isolator washer (8)	90678-94
12	Isolator bushing (8)	90676-94
13	Isolator (8)	90677-94
14	Screw, button head, 5/16-24 x 1.25 (8)	90578-94
15	Support, left	90608-96A
16	Support, right (not shown)	90625-96A
17	Saddlebag, LH, for Kit 90201306 Saddlebag, LH, for Kit 90201329	90201307 90303-98B
18	Saddlebag, RH, for Kit 90201306 (not shown) Saddlebag, RH, for Kit 90201329 (not shown)	90201308 90304-98B
19	Leather care kit (1) (not shown)	Not Sold Separately
20	Disconnect, male with buckle, for Kit 90201329 (not shown)	88295-07
	Disconnect, male with buckle, for Kit 90201306 (not shown)	90201417
21	Medallion, for Kit 90201329 (not shown)	14100857
<b>Items mentioned in text, but not included in kit:</b>		
A	Fender support cover and hardware	
B	Rear directional relocation pad (2)	Included with Turn Signal Relocation Kit (part number 68474-04)
C	Screw	