



INSTRUCTIONS

-J05382

2011-06-03

DYNA SWINGARM BAG

GENERAL

Kit Numbers

90200570, 90200571

Models

For model fitment information, see the P&A retail catalog or the Parts and Accessories section of www.harley-davidson.com (English only).

▲ WARNING

The rider's safety depends upon the correct installation of this kit. If the procedure is not within your capabilities or you do not have the correct tools, have a Harley-Davidson dealer perform the installation. Improper installation of this kit could result in death or serious injury. (00308a)

Additional Parts Required

This kit is intended to be installed on solo rider motorcycles only. If the motorcycle is currently equipped to carry a passenger a solo seat must be installed.

Kit Contents

See Figure 5 and Table 1.

REMOVAL

Models with Passenger Footrests

1. Install a solo seat on the motorcycle according to the instructions included in that kit.
2. Remove screw and washer from left passenger footrests support to detach the belt guard. Save screw and washer for later installation.
3. Remove two screws, two washers and left passenger footrest supports. Save screws and washers for later installation.
4. Remove two screws, two washers and right passenger footrest supports.

Models without Passenger Footrests

1. Remove screw and washer from belt guard bracket to detach the belt guard. Save screw and washer for later installation.
2. Remove two screws, two washers and belt guard bracket. Save screws and washers for later installation.

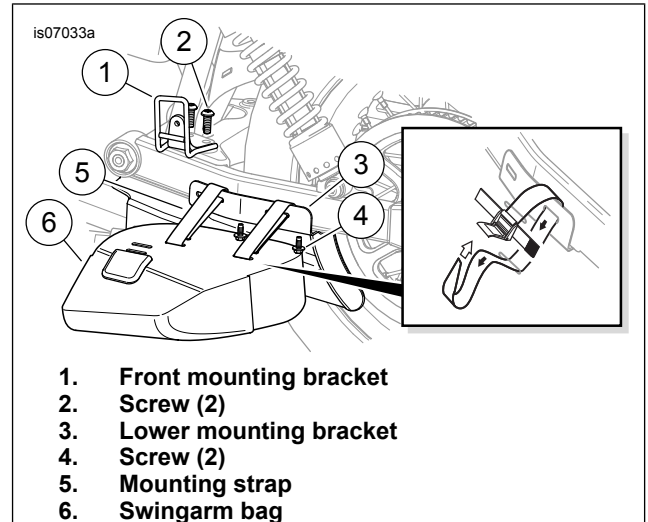

Figure 1. Install Saddlebag Brackets

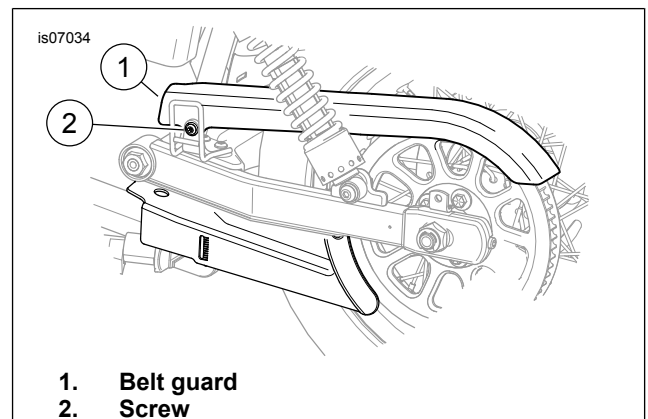

Figure 2. Install Belt Guard

INSTALLATION

1. See Figure 1. Install front mounting bracket (1) in the left passenger footrest location using screws (2) removed earlier.
2. See Figure 2. Install belt guard (1) to the front mounting bracket. Install the screw (2) removed earlier and tighten to 34–47 N·m (25–35 ft-lbs).
3. See Figure 1. Loosely attach swingarm bag (6) to lower mounting bracket (3) (before attaching to the motorcycle):
 - a. Insert a mounting strap (5), with the cam lock lever facing up, from inside the bag through the top slot of lower mounting slots.
 - b. Route the mounting strap (5) over the top of the mounting bracket and back through the slot.
 - c. Route the mounting strap (5) into the bag through the bottom slot of the lower mounting slots.



- d. Route the mounting strap (5) through the cam lock, but do not tighten the strap at this time.
 - e. Repeat for the other lower mounting strap.
4. See Figure 1. Install lower mounting bracket (3) to the swingarm:
- a. Remove the two rear screws attaching the debris deflector to the swingarm.
 - b. Install lower mounting bracket (3) to the debris deflector and swingarm with the screws (4) that were removed. Tighten to 4.5–6.7 N·m (40–60 in-lbs).
5. See Figure 3. Secure the swingarm bag (1) to the front mounting bracket (2):
- a. Slide pocket on the back of the swingarm bag over the front mounting bracket.
 - b. Insert a strap, with the cam lock lever facing up, from inside the bag through the top slot of front mounting slots.
 - c. Route the strap around the bar of the front mounting bracket.
 - d. Route the strap into the bag through the bottom slot of the front mounting slots.

NOTE

Even with the straps fully tightened, the saddlebag may still feel loose. This is normal.

- e. Route the strap through the cam lock.
6. See Figure 4. Tighten each strap as much as possible, and lock down the clamp (1). Fold the hook-and-loop straps (2 and 3) over the closed clamp to secure it.

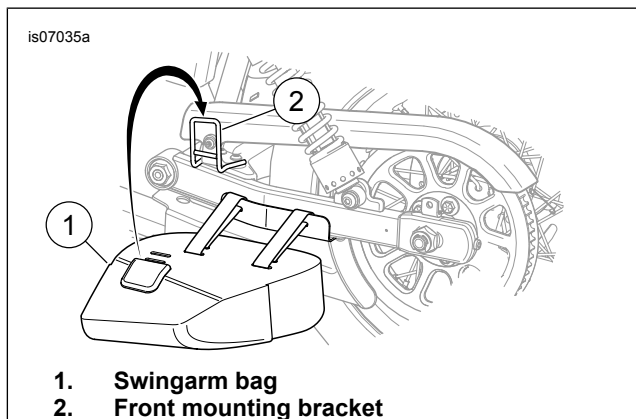

Figure 3. Install Swingarm Bag

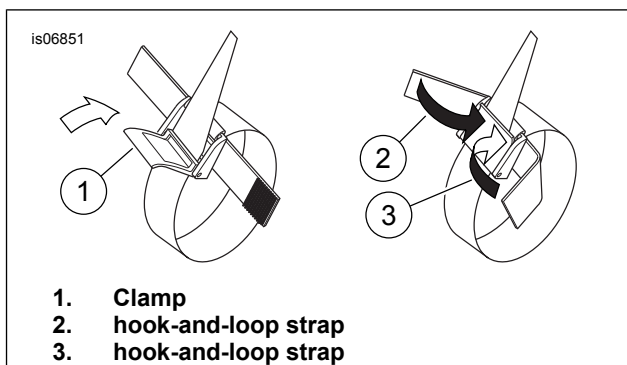

Figure 4. Lock Down and Secure Clamp

IN USE

⚠ WARNING

Do not exceed swingarm bag weight capacity. Too much weight in swingarm bag can cause loss of control, which could result in death or serious injury. (00618c)

NOTE

Maximum swingarm bag weight capacity is 2.3 kg (5 lb).

Use the Leather Care from the kit regularly to preserve the appearance and extend the life of the swingarm bag. Additional leather care products are available from a Harley-Davidson dealer.

SERVICE PARTS

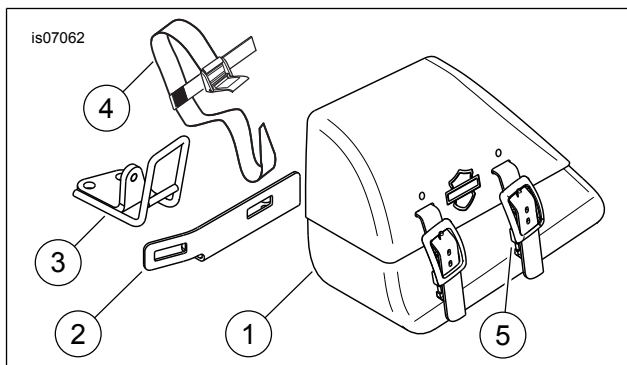

Figure 5. Service Parts: Dyna Swingarm Bag

Table 1. Service Parts

Item	Description (Quantity)	Part Number
1	Swingarm bag	Not Sold Separately
2	Mounting bracket, lower	Not Sold Separately
3	Mounting bracket, front	Not Sold Separately
4	Mounting strap (3)	90200671
5	Buckle, male disconnect (2)	90200672
6	Leather Care, 0.75 oz (Not Shown)	Not Sold Separately