



INSTRUCTIONS

-J01901

REV. 2008-06-04

SOFTAIL SADDLEBAG KITS

GENERAL

Kit Numbers

88263-07, 88286-07, 90058-05B, 90119-00C, 90130-00D, 90133-06B, 90320-00D, 91536-00C, 91537-00C, 91555-01B, 92000-00C

Models

For model fitment information, see the P&A Retail Catalog or the Parts and Accessories section of www.harley-davidson.com (English only).

These Saddlebag Kits will fit with 2007 FXSTSSE/2/3 models. To fit on these models, the decorative fender strip must be removed first.

Additional Parts Required

Loctite® 243 Threadlocker and Sealant - Blue (99642-97) is available from a Harley-Davidson dealer.

Kit Contents

Table 1. Kit Contents

Fitment	See:
2000-2002 FXST, 2000-2002 FLST and 1984-1999 FXST	Figure 5 and 6, Table 4 and 5
2003-Later Softail (except 2007 FXSTC)	Figure 7 and 8, Table 6 and 7
2007 FXSTC	Figure 9, Table 8

Saddlebag Part Numbers

The following table lists the kit numbers and corresponding part numbers for the individual saddlebags.

Table 2. Saddlebag Part Numbers

Description	Part Number
Kit 88263-07:	
Saddlebag, Right	88266-07
Saddlebag, Left	88267-07
Kit 88286-07:	
Saddlebag, Right	88288-07
Saddlebag, Left	88287-07
Kit 90058-05B:	
Saddlebag, Right	90053-05
Saddlebag, Left	90054-05
Kit 90119-00C:	
Saddlebag, Right	90120-00
Saddlebag, Left	90195-00
Kit 90130-00D:	
Saddlebag, Right	90132-00A
Saddlebag, Left	90131-00A
Kit 90133-06B:	
Saddlebag, Right	90145-06B
Saddlebag, Left	90146-06B
Kit 90320-00D:	
Saddlebag, Right	90390-00A
Saddlebag, Left	90389-00A
Kit 91536-00C:	
Saddlebag, Right	91546-00
Saddlebag, Left	91547-00
Kit 91537-00C:	
Saddlebag, Right	91548-00
Saddlebag, Left	91549-00
Kit 91555-01B:	
Saddlebag, Right	Not Sold Separately
Saddlebag, Left	Not Sold Separately
Kit 92000-00C:	
Saddlebag, Right	92004-00A
Saddlebag, Left	92003-00A

INSTALLATION

WARNING

Do not exceed saddlebag weight capacity. Put equal weight in each bag. Too much weight in saddlebags can cause loss of control, which could result in death or serious injury. (00383a)

NOTES

Maximum saddlebag weight capacity is 7 lbs (3.18 kg) for each bag.

Proper installation of these kits requires that tasks be completed for one side of the motorcycle first before continuing to the opposite side.

2000-2002 Models with Wide Tire Kit

1. See Figure 1. Remove and discard stock screws (1) and washers (2) from fender support.

WARNING

Button head screws from wide tire kit must be installed with button heads on inside of fender. Fastener contact with tire can lead to premature tire failure, which could result in death or serious injury. (00417b)

2. See Table 3. Determine appropriate screw from wide tire kit.
3. See Figure 2. Install saddlebag using screw (from wide tire kit) (1), washer (2) and nut (3). The screws are installed from inside to outside of fender.

NOTE

If you do not have the appropriate screw from the wide tire kit, it can be purchased from a Harley-Davidson dealer.

Table 3. Wide Tire Kit Screws (3/8-16)

Part Number and Length	Wide Tire Kit 44490-00, Hardware Kit 43761-00	Wide Tire Kit 44490-00, Hardware Kit 43763-00
4030 - 2-1/2 inch	X	X
4225 - 3-1/2 inch	X	X
4224 - 1-1/2 inch	X	X
4044 - 1-1/4 inch	X	X
4215 - 2 inch	X	
3912 - 2-3/4 inch		X
4228 - 2-1/4 inch	X	X
4229 - 3-1/4 inch	X	X

CAUTION

Failure to tighten saddlebag mounting bolts to specified torque could result in damage to saddlebags. (00406c)

4. Tighten all saddlebag hardware to 22 ft-lbs (30 Nm).

NOTE

Check that front screws have at least one thread exposed beyond the nut after proper torque has been applied.

5. Install reflectors on saddlebag. Refer to Install Reflectors subtopic.

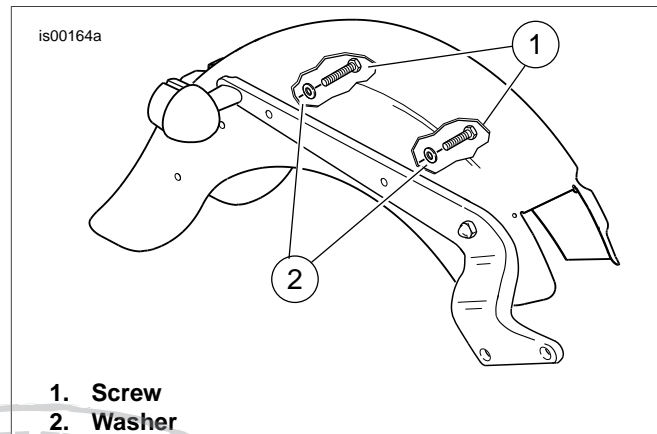

1. Screw
2. Washer

Figure 1. Remove Fender Support Hardware (FLST)

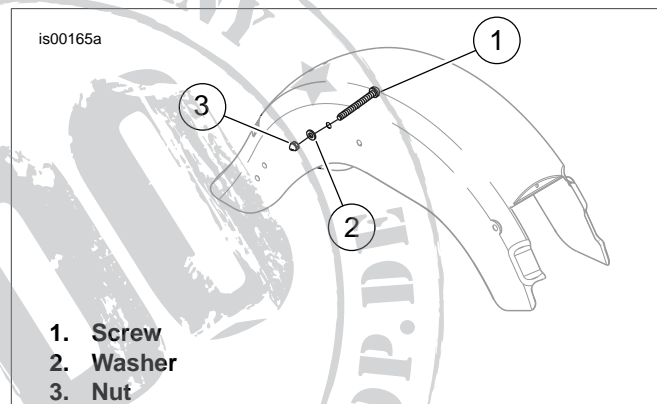

1. Screw
2. Washer
3. Nut

Figure 2. Install Fender Support Hardware (FLST)

2000 and Earlier Models without Wide Tire Kit

1. See Figure 1. Remove and discard stock screws (1) and washers (2) from fender support.
2. See Figure 5 and Figure 6. Attach front of saddlebag (1) to fender using screw (2) washer (3) and nut (4).
3. Attach rear of saddlebag to fender as follows:
 - a. **FLST, FLSTF models:** See Figure 6. Use the correct screw (6), washer (3) (not used on 1984-1999 models) and acorn nut (7) as shown. Hand-tighten to keep in place.
 - b. **FXST models:** See Figure 5. Use the correct screw (6) and washer (7) as shown. The screw threads into the insert in the license plate bracket (A). Hand-tighten to keep in place.

NOTE

If the saddlebag hanger contacts the rear turn signal, it will be necessary to loosen the turn signal and adjust to allow clearance with the saddlebag hanger as follows:

- Loosen the turn signal mount screw 2-3 turns.
- Adjust rearward to allow approximately 0.03 in (0.40 mm) of clearance between the turn signal and the saddlebag hanger.
- Tighten the turn signal mount screws.

CAUTION

Failure to tighten saddlebag mounting bolts to specified torque could result in damage to saddlebags. (00406c)

4. Tighten all saddlebag hardware to 22 ft-lbs (30 Nm).

NOTE

Check that front screws have at least one thread exposed beyond the nut after proper torque has been applied.

5. See Figure 5 and Figure 6. Slip the thread protector (5) over the end of front screw (2).
6. Install reflectors on saddlebag. Refer to Install Reflectors subtopic.

2003 and Later Softail Models (Except FXSTC)

1. See Figure 3 and Figure 4. Remove and discard stock screws (1) from fender support (2).
2. Attach saddlebag to rear fender as follows:

Saddlebags without Rigid-Mount Sissy Bar Sideplates (See Figure 7.)

Kits 90130-00D, 90320-00D:

- a. Apply Loctite 243 (blue) to last 0.50 in (13 mm) of thread on screw (2).
- b. Install front of saddlebag (1) with screw (2) and washer (3).
- c. Install rear of saddlebag (outside location) with screw (2) and two washers (3).

Kits 88286-07, 90058-05B, 90119-00C, 90133-06A, 91536-00C, 91537-00C, 91555-01B and 92000-00C:

- a. Apply Loctite 243 (blue) to last 0.50 in (13 mm) of thread on screw (2, 4).
- b. Install front of saddlebag with screw (2) and two washers (3).
- c. Install rear of saddlebag with screw (4) and washer (3).

Saddlebags with Rigid-Mount Sissy Bar Sideplates
See Figure 8.

Kits 90130-00D, 90320-00D:

- a. Apply Loctite 243 (blue) to last 0.50 in (13 mm) of thread on screw (2, 4).
- b. Install front of saddlebag with screw (2) and two washers (3).
- c. Install rear of saddlebag (outside location) with screw (4) and washer (3).

Kits 90058-05B, 90119-00C, 90133-06A, 91536-00C, 91537-00C, 91555-01B and 92000-00C:

- a. Apply Loctite 243 (blue) to last 0.50 in (13 mm) of thread on screw (4).
- b. Install front of saddlebag with screw (4) and washer (3).
- c. Install rear of saddlebag (outside location) with screw (4) and two washers (3).

CAUTION

Failure to tighten saddlebag mounting bolts to specified torque could result in damage to saddlebags. (00406c)

3. Tighten all saddlebag hardware to 22 ft-lbs (30 Nm).

NOTES

Check that screws are approximately flush with the inside surface of the fender bracket nut after proper torque has been applied.

Screws should not extend beyond the fender bracket nut by more than 0.06 to 0.12 in (1.6 to 3.2 mm) to give adequate tire clearance. Screws should not be shorter than 0.06 to 0.12 in (1.6 to 3.2 mm) below the inside surface of the nut. If they are, check to make sure the proper screw was used.

4. Install reflectors on saddlebag. Refer to Install Reflectors subtopic.

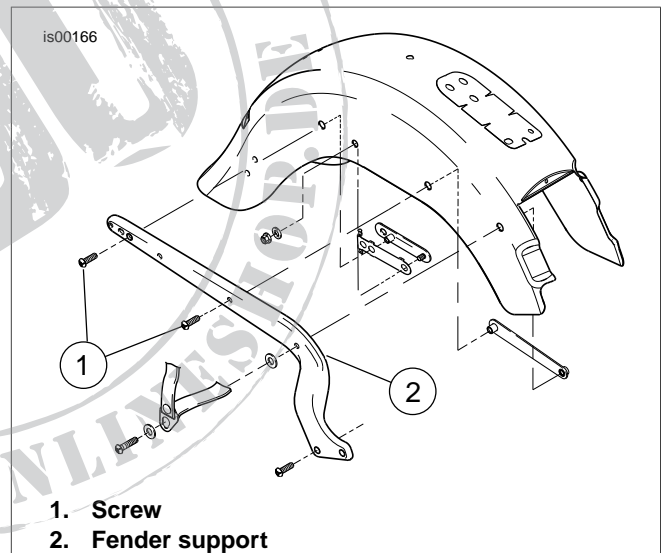
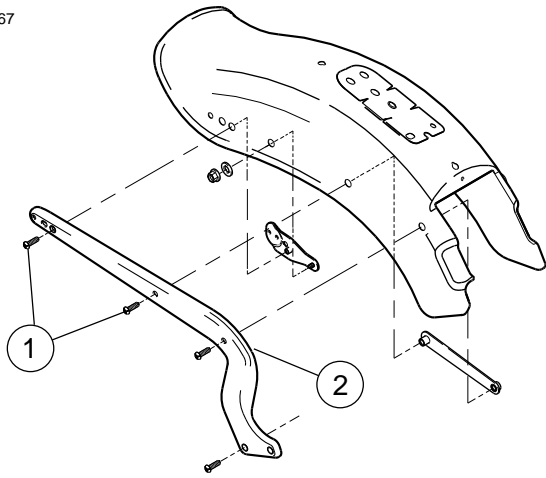

Figure 3. Fender Support Hardware (2006 FLSTF)



1. Screw
2. Fender support

Figure 4. Fender Support Hardware (2006 FXST/S/B)

2007 FXSTC Models

1. See Figure 4. Remove and discard stock screws (1) from fender support (2).
2. See Figure 9. Apply Loctite 243 (blue) to last 0.50 in (13 mm) of thread on screw (2, 5).
3. Install front of saddlebag (1) using screw (2), washer (3) and spacer (4).
4. Install rear of saddlebag (1) using screw (5), washer (3) and spacer (4).

CAUTION

Failure to tighten saddlebag mounting bolts to specified torque could result in damage to saddlebags. (00406c)

5. Tighten all saddlebag hardware to 22 ft-lbs (30 Nm).

NOTES

Check that screws are approximately flush with the inside surface of the fender bracket nut after proper torque has been applied.

Screws should not extend beyond the fender bracket nut by more than 0.06 to 0.12 in (1.6 to 3.2 mm) to give adequate tire clearance. Screws should also not be shorter than 0.06 to 0.12 in (1.6 to 3.2 mm) below the inside surface of the nut. If they are, check to make sure the proper screw was used.

6. Install reflectors on saddlebag. Refer to Install Reflectors subtopic.

Install Reflectors

WARNING

Federal Motor Vehicle Safety Standard (FMVSS) 108 requires motorcycles to be equipped with rear and side reflectors. Be sure rear and side reflectors are properly mounted. Poor visibility of rider to other motorists can result in death or serious injury. (00336b)

1. See Figure 5 through Figure 9. Position reflector mount on lower right corner of saddlebag.
2. Mark holes on saddlebag with pen or other appropriate tool.
3. Clean the surface where the reflector will be installed with soapy water.
4. Allow the surface to dry completely before continuing.
5. Remove adhesive from back of reflector and install on reflector mount. Apply pressure to reflector for at least one minute.
6. Using appropriate tool, make two 0.1875 in (4.8 mm) holes in saddlebag at locations marked in Step 2.
7. Install reflector mount on saddlebag using two push nuts. The push nuts are installed from inside the saddlebag.
8. Let the adhesive cure for at least 24 hours at no less than 60 °F (16 °C).

Install Opposite Saddlebag

Repeat all steps for the opposite side.

MAINTENANCE

Docking Point Screws

CAUTION

Failure to tighten saddlebag mounting bolts to specified torque could result in damage to saddlebags. (00406c)

After 500 miles of on road use with the saddlebags installed, it is necessary to check the torque on the saddlebag mounting screws. Check to make sure the torque is 22 ft-lbs (30 Nm). Tighten screws if necessary.

Saddlebag Docking Points

NOTE

In time the docking points may wear, causing the lower front support brackets to become loose. The fit may be tightened using the following procedure:

1. Loosen docking point hardware.
2. Rotate docking points clockwise approximately 45 degrees.
3. Tighten docking point hardware to 22 ft-lbs (30 Nm).

This procedure can be repeated up to three times before replacement of the docking points is recommended.

Saddlebag Care

- For saddlebags with lid snaps, it will be necessary to periodically oil the snaps. Smear a drop of motor oil into the female side of the snap, being careful not to get any of the oil on the leather. Oil the snaps every two-three weeks.
- Apply the Genuine Leather Dressing (98261-91V) included with the saddlebag according to the instructions in the leather care kit.

SERVICE PARTS

is03277

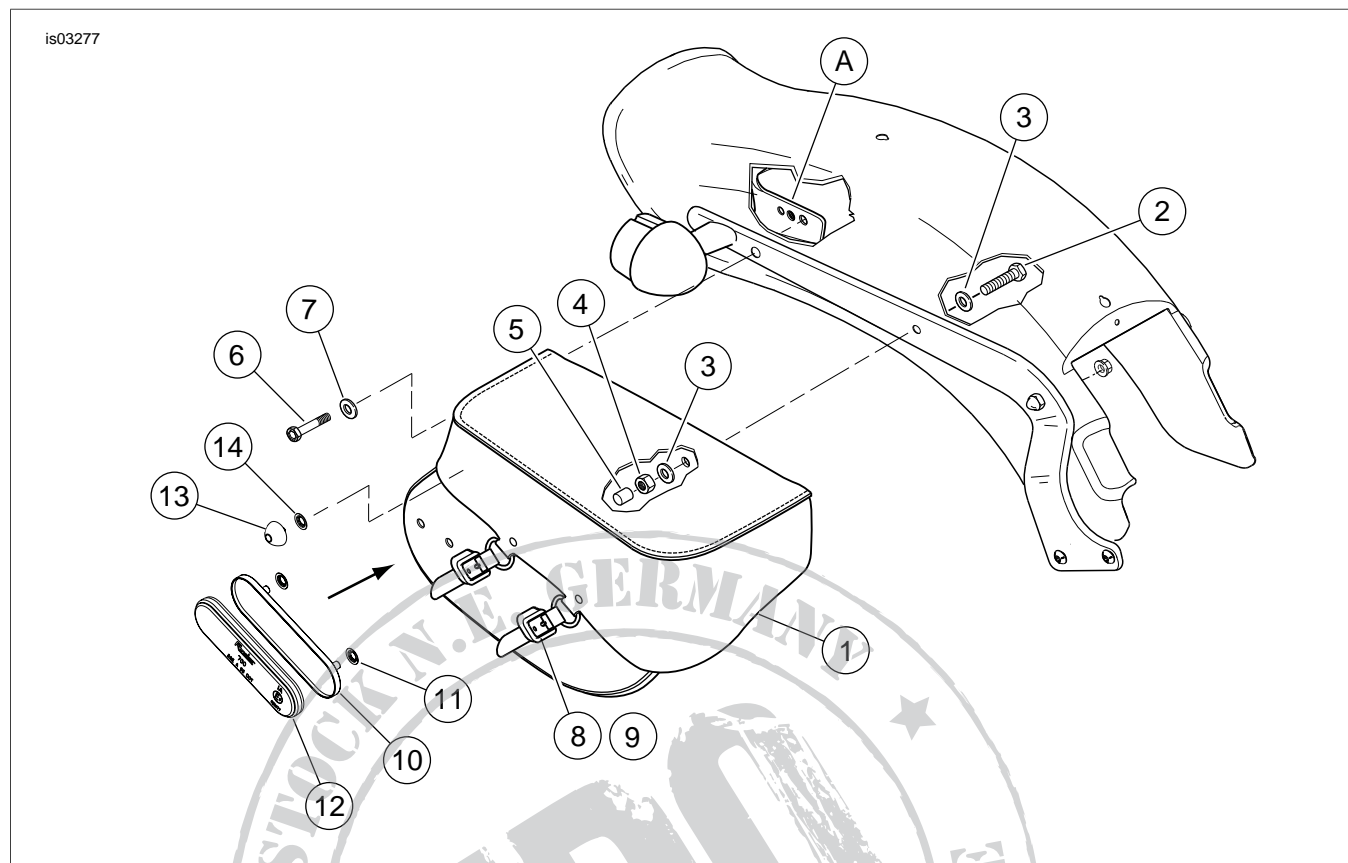

Figure 5. Service Parts: Softtail Saddlebag Kits (Installation Shown on 2000-2002 FXST Models)

Table 4. Service Parts: Softtail Saddlebag Kits (2000-2002 FXST Models)

Item	Description (Quantity)	Part Number	Item	Description (Quantity)	Part Number
1	Saddlebag, right	See Table 2	9	Clip, female (Kits 90058-05B and 90133-06A only)	90454-04
	Saddlebag, left (not shown)	See Table 2	10	Mount, reflector (2)	See Service Kits
2	Screw, 3/8-16 x 2-3/4 in (2)	4420	11	Push nut, reflector (4)	8126A
3	Washer, 3/8 in (6)	6400HB	12	Reflector (2)	59173-00
4	Locknut, 3/8-16 (2)	7778	13	Decorative stud, FLSTF (Kit 88286-07 only)	88290-07
5	Thread protector (2)	Not Sold Separately	14	Push nut, decorative stud (6)	8126A
6	Screw, 3/8-16 x 2-1/2 in (2) (used with rigid-mount sissy bar)	9470	Service Kits:		
	Screw, 3/8-16 x 2-1/4 in (2) (not used with rigid-mount sissy bar)	9469	15	Reflector Kit (includes Items 10, 11, 12)	59480-04
7	Lockwasher, 3/8 in (2)	7038	16	Concho Kit (includes concho, backing plate, push nuts) (Kit 90320-00D only)	90078-99
8	Clip, male with chrome buckle (Kits 90058-05B and 90133-06A only)	90453-04	Items mentioned in text, but not included in kit:		
	Clip, female with chrome buckle (Kit 88286-07 only)	90474-07	A	Not used on 1984-1999 models.	
	Clip, male with chrome buckle (Kit 90133-06B)	90503-09			

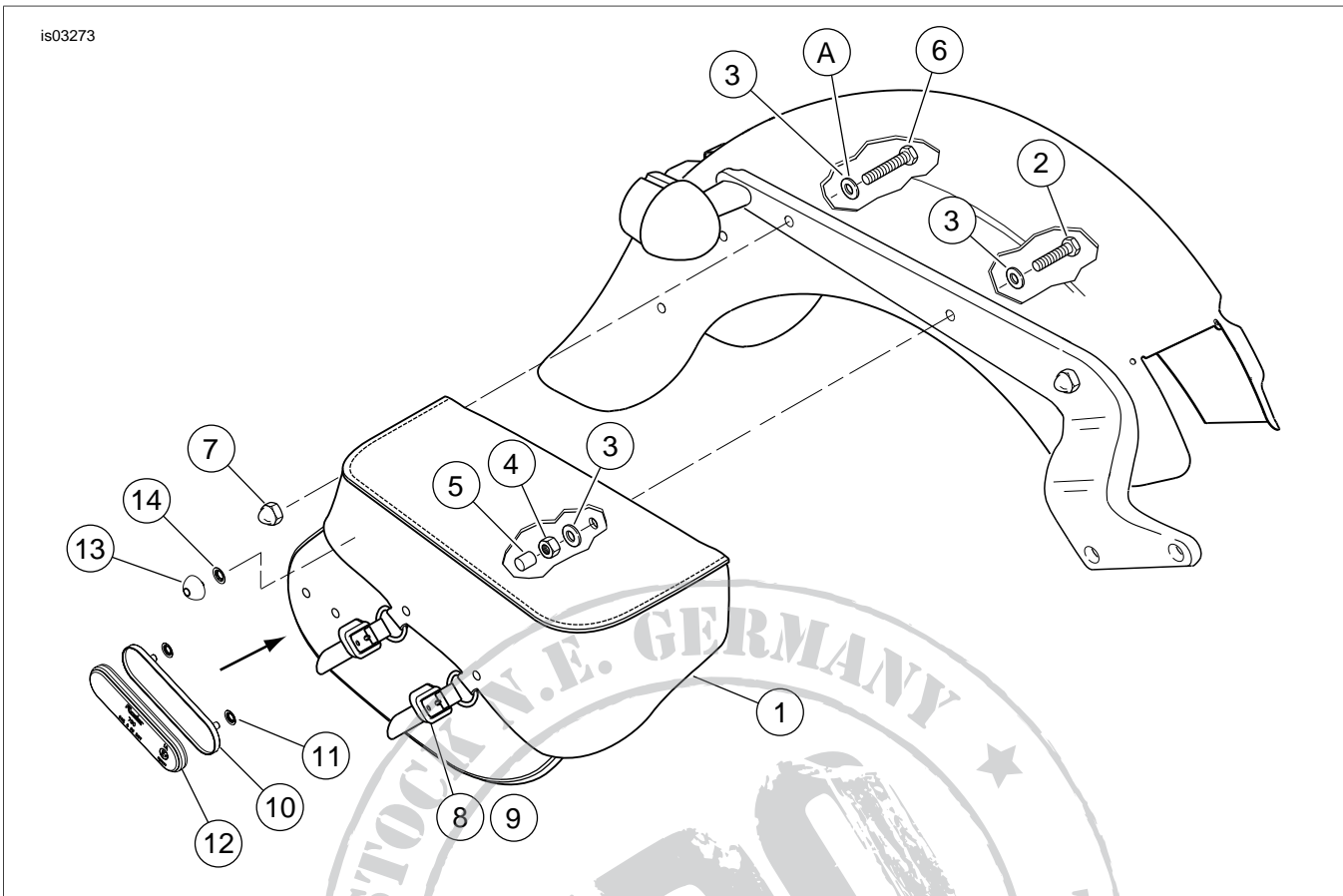

Figure 6. Softtail Saddlebag Kits (Installation Shown on 2000-2002 FLST and 1984-1999 FLSTF, FXST Models)

Table 5. Service Parts: Softtail Saddlebag Kits (2000-2002 FLST and 1984-1999 FLSTF, FXST Models)

Item	Description (Quantity)	Part Number	Item	Description (Quantity)	Part Number
1	Saddlebag, right	See Table 2	9	Clip, female (Kits 90058-05B and 90133-06A only)	90454-04
	Saddlebag, left (not shown)	See Table 2	10	Mount, reflector (2)	See Service Kits
2	Screw, 3/8-16 x 2-3/4 in (2)	4420	11	Push nut, reflector (4)	8126A
3	Washer, 3/8 in (6)	6400HB	12	Reflector (2)	59173-00
4	Locknut, 3/8-16 in (2)	7778	13	Decorative stud, FLSTF (Kit 88286-07 only)	88290-07
5	Thread protector (2)	Not Sold Separately	14	Push nut, decorative stud (6)	8126A
6	Screw, 3/8-16 x 2-1/2 in (2) (used with rigid-mount sissy bar)	9470	Service Kits:		
	Screw, 3/8-16 x 2-1/4 in (2) (not used with rigid-mount sissy bar)	9469	15	Reflector Kit (includes Items 10, 11, 12)	59480-04
7	Acorn nut (2)	7862	16	Concho Kit (includes concho, backing plate, push nuts) (Kit 90320-00D only)	90078-99
8	Clip, male with chrome buckle (Kits 90058-05B and 90133-06A only)	90453-04	Items mentioned in text, but not included in kit:		
	Clip, female with chrome buckle (Kit 88286-07 only)	90474-07	A	Not used on 1984-1999 models.	
	Clip, male with chrome buckle (Kit 90133-06B)	90503-09			

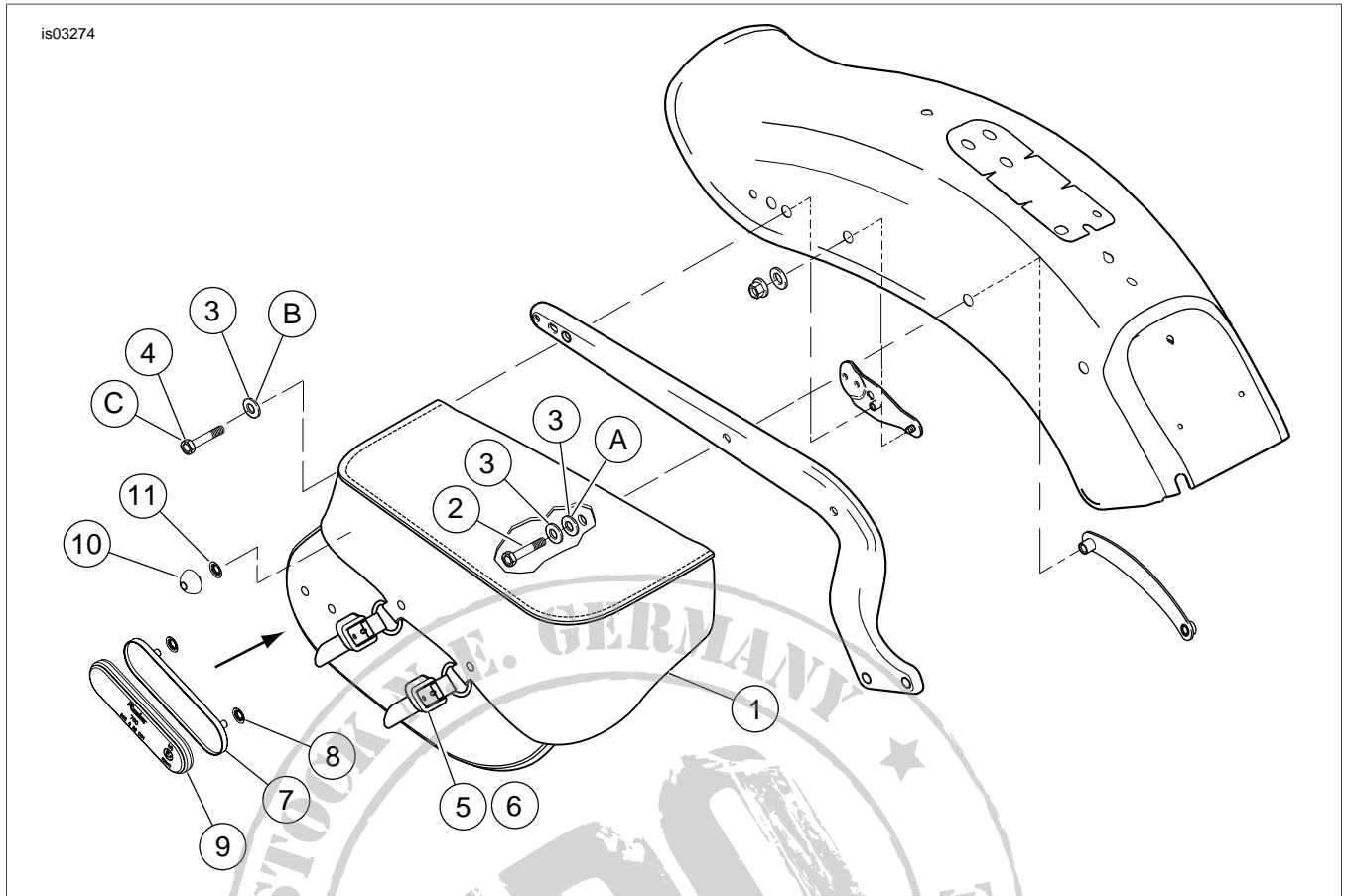

Figure 7. Saddlebag Kits (Installation Shown on 2003-Later without Rigid Mount Sissy Bar)

Table 6. Service Parts: Softtail Saddlebag Kits (2003-Later without Rigid-Mount Sissy Bar)

Item	Description (Quantity)	Part Number	Item	Description (Quantity)	Part Number
1	Saddlebag, right	See Table 2	9	Reflector (2)	59173-00
	Saddlebag, left (not shown)	See Table 2	10	Decorative stud, FLSTF (Kit 88286-07 only)	88290-07
2	Screw, 3/8-16 x 2-1/4 in (4)	9469	11	Push nut, decorative stud (6)	8126A
3	Washer, 3/8 in (6)	6400HB	Service Kits:		
4	Screw, 3/8-16 x 2 in (2)	9468	12	Reflector Kit (includes Items 7, 8, 9)	59480-04
5	Clip, male with chrome buckle (Kits 90058-05B and 90133-06A only)	90453-04	13	Concho Kit (includes concho, backing plate, push nuts) (Kit 90320-00D only)	90078-99
	Clip, female with chrome buckle (Kit 88286-07 only)	90474-07			
	Clip, male with chrome buckle (Kit 90133-06B)	90503-09	Items mentioned in text, but not included in kit:		
6	Clip, female (Kits 90058-05B and 90133-06A only)	90454-04	A	Kits 90130-00D and 90320-00D use two washers.	
7	Mount, reflector (2)	See Service Kits	B	Kits 90130-00D and 90320-00D use one washer.	
8	Push nut, reflector (4)	8126A	C	Kits 90130-00D and 90320-00D use 2-1/4 inch screw (Item 2). All other kits use 2 inch screw (Item 4).	

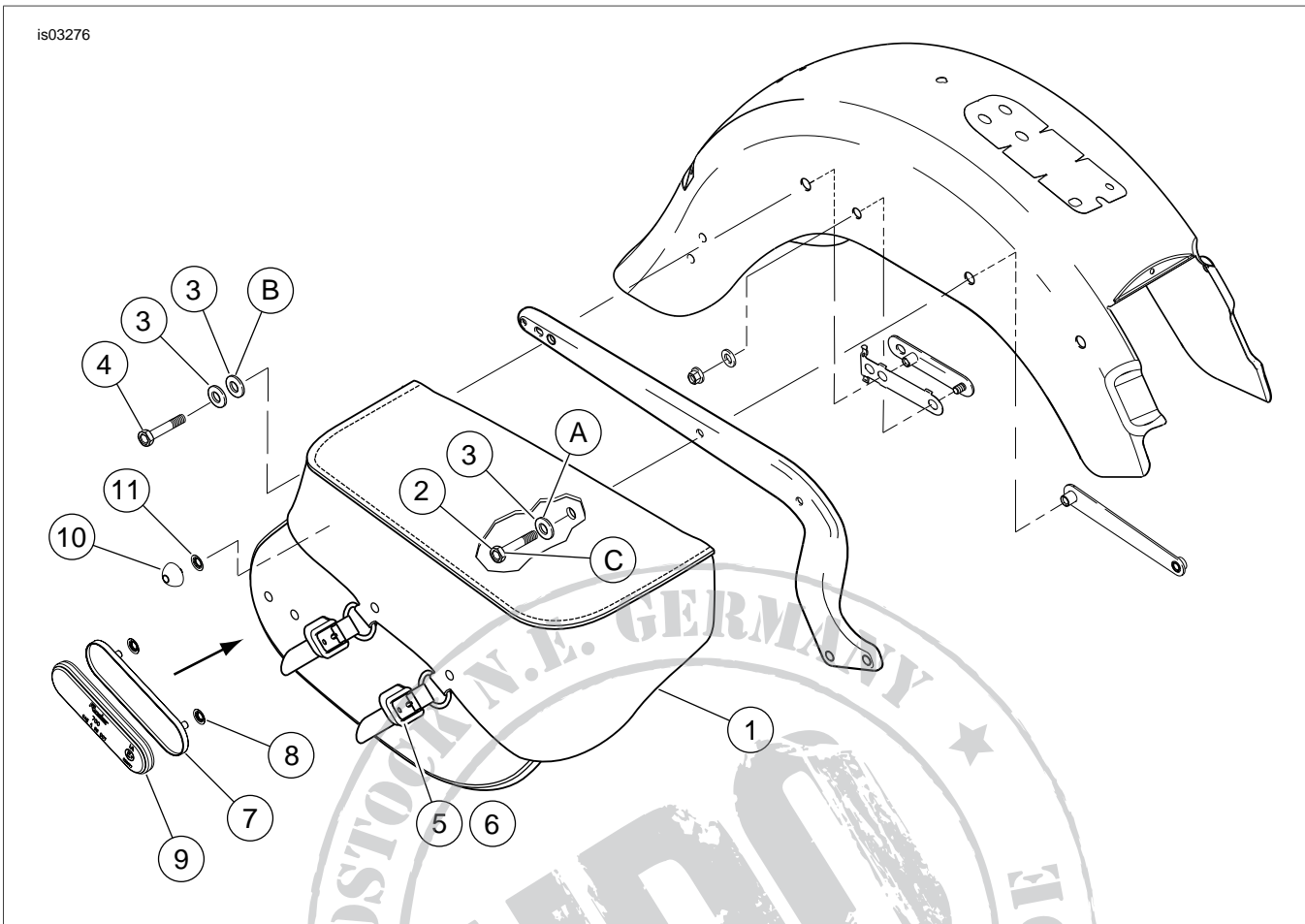

Figure 8. Softtail Saddlebag Kits (Installation Shown on 2003-Later with Rigid Mount Sissy Bar)

Table 7. Service Parts: Softtail Saddlebag Kits (2003-Later With Rigid-Mount Sissy Bar)

Item	Description (Quantity)	Part Number	Item	Description (Quantity)	Part Number
1	Saddlebag, right Saddlebag, left (not shown)	See Table 2 See Table 2	9	Reflector (2)	59173-00
2	Screw, 3/8-16 x 2-1/2 in (2)	9470	10	Decorative stud, FLSTF (Kit 88286-07 only)	88290-07
3	Washer, 3/8 in (6)	6400HB	11	Push nut, decorative stud (6)	8126A
4	Screw, 3/8-16 x 2-1/4 in (4)	9469	Service Kits:		
5	Clip, male with chrome buckle (Kits 90058-05B and 90133-06A only)	90453-04	12	Reflector Kit (includes Items 7, 8, 9)	59480-04
	Clip, female with chrome buckle (Kit 88286-07 only)	90474-07	13	Concho Kit (includes concho, backing plate, push nuts) (Kit 90320-00D only)	
	Clip, male with chrome buckle (Kit 90133-06B)	90503-09	Items mentioned in text, but not included in kit:		
6	Clip, female (Kits 90058-05B and 90133-06A only)	90454-04	A	Kits 90130-00D and 90320-00D use two washers.	
7	Mount, reflector (2)	See Service Kits	B	Kits 90130-00D and 90320-00D use one washer.	
8	Push nut, reflector (4)	8126A	C	Kits 90130-00D and 90320-00D use 2-1/2 inch screw (Item 2). All other kits use 2-1/4 inch screw (Item 4).	

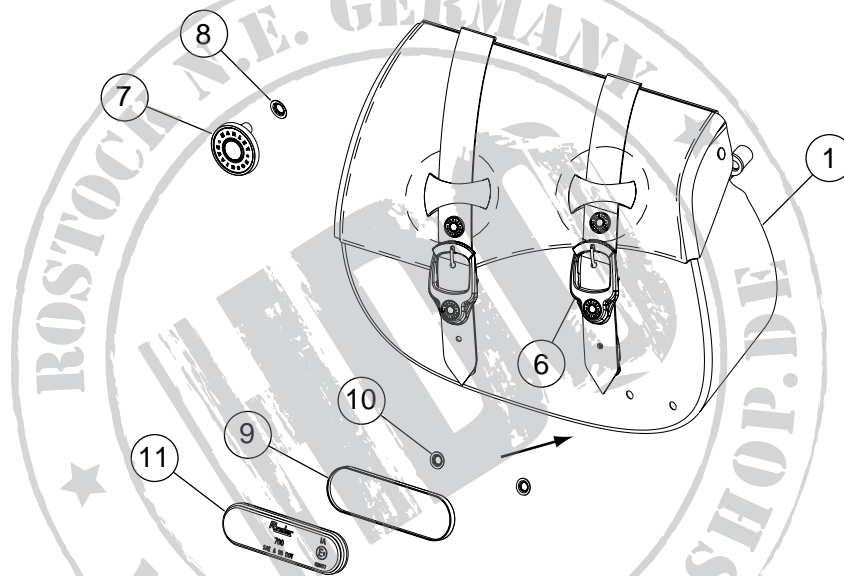
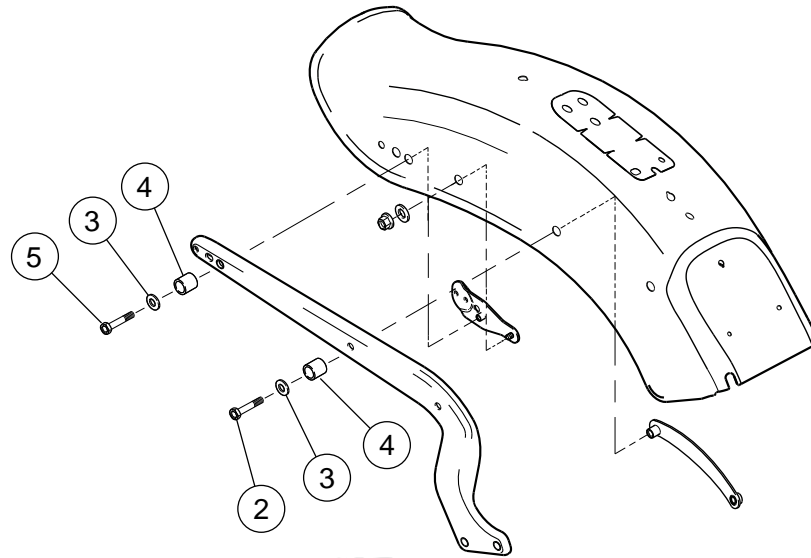

Figure 9. Service Parts: 2007 FXSTC Saddlebag Kit

Table 8. Service Parts: 2007 FXSTC Saddlebag Kit

Item	Description (Quantity)	Part Number	Item	Description (Quantity)	Part Number
1	Saddlebag, left	See Table 2	8	Push nut, concho (16)	8126A
	Saddlebag, right (not shown)	See Table 2	9	Mount, reflector (2)	See Service Kits
2	Screw, 3/8-16 x 3 in (2)	4205	10	Push nut, reflector (4)	8126A
3	Washer, 3/8 in (4)	6400HB	11	Reflector (2)	59173-00
4	Spacer (4)	11825	Service Kits:		
5	Screw, 3/8-16 x 2-3/4 in (2)	3509	12	Reflector Kit (includes Items 9, 10, 11)	59480-04
6	Chrome buckle with female clip	88268-07	13	Hardware Kit (includes Items 2, 4, 5)	90573-07
7	Concho, FXSTC	88269-07			