



# INSTRUCTIONS

-J05012

REV. 2010-01-11

## DOCKING HARDWARE KIT

### GENERAL

#### Kit Number

88390-10

#### Models

For model fitment information, see the P&A Retail Catalog or the Parts and Accessories section of [www.harley-davidson.com](http://www.harley-davidson.com) (English only).

#### Additional Parts Required

Detachable accessories docking kit 53529-04 is required for installation of other detachable accessories.

Rear Turn-Signal relocation kit necessary for the installation of detachable saddlebags. See your dealer for a turn-signal relocation kit appropriate for your model motorcycle.

Loctite® 243 (Blue) Threadlocker and Sealant (p/n 99642-97) is required for the proper installation of this kit.

#### WARNING

The rider's safety depends upon the correct installation of this kit. Use the appropriate service manual procedures. If the procedure is not within your capabilities or you do not have the correct tools, have a Harley-Davidson dealer perform the installation. Improper installation of this kit could result in death or serious injury. (00333a)

#### NOTE

*This instruction sheet references service manual information. A service manual for your model motorcycle is required for this installation and is available from a Harley-Davidson Dealer.*

#### Kit Contents

See Figure 3 and Table 1.

### INSTALLATION

#### Remove

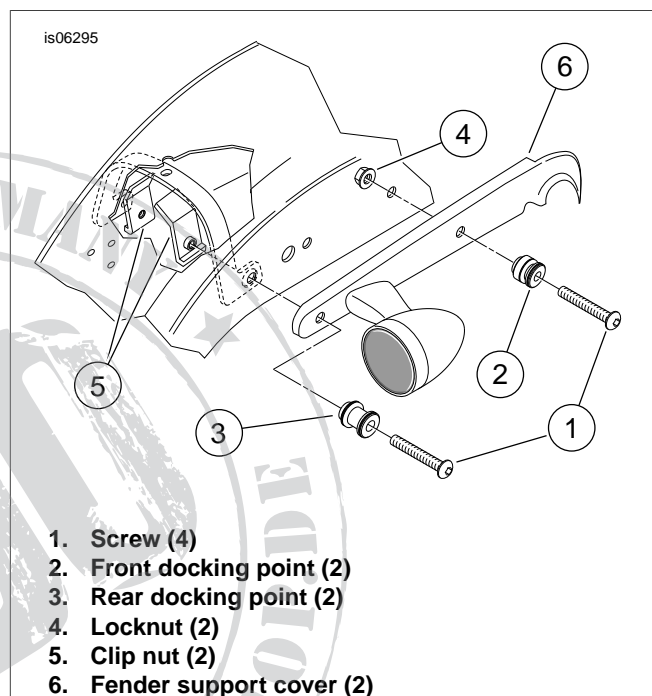

Figure 1. Rear Fender Support

1. See Figure 1. Remove the front screw (1) and locknut (4) from the rear-fender support cover (6). Discard the screw. Discard the stock locknut if docking points were not previously installed. Retain the front docking point (2) and locknut (4) if docking points previously installed.
2. Remove the rear screw (1) and clip nut (5) from the rear fender support cover taking note of the orientation of the clip nut inside the fender supports. Discard the screw, but retain the clip nut. Retain the rear docking point (3) if previously installed.
3. Remove and relocate the rear turn-signals from the rear fender support covers (6) per instructions provided in the service manual and relocation kit.
4. See Figure 3. If support arms are already assembled to the saddlebags, remove screws, lock and flat washers and support arms from the saddlebags. Retain the support arms and washers. Discard the screws.

## Install

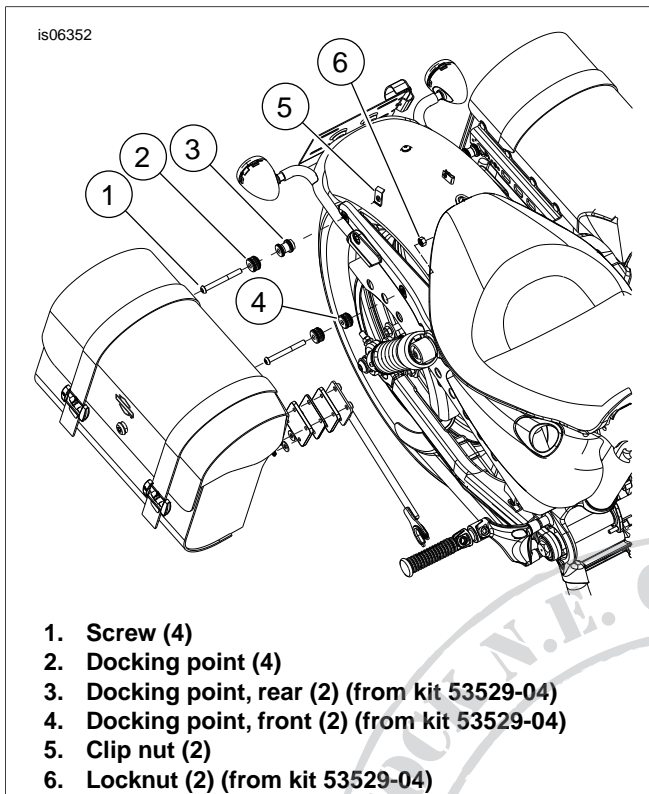

Figure 2. Docking Hardware Stack-Up

1. See Figure 2. Obtain a docking point (2) and screw (1) from the kit, and front docking point (4) and locknut (6) removed earlier. Note the small diameter collar on one end of both docking points.
2. Place the docking points onto the screw threads as shown with both collar ends farthest from the screw head. Coat the last 4 to 6 screw threads with a few drops of Loctite 243 (Blue). Insert the screw into the forward rear fender support hole, fitting the collar on the front docking point toward the hole.
3. Thread the locknut onto the screw threads from underneath the fender. Tighten the locknut to 15 ft-lbs (20 Nm).
4. Obtain a docking point (2) and screw (1) from the kit, and rear docking point (3) and clip nut (5) removed earlier. Note the small diameter collar on one end of both docking points.
5. Place the docking points onto the screw threads with both collar ends farthest from the screw head. Coat the last 4 to 6 screw threads with a few drops of Loctite 243 (Blue). Insert the screw into the rearmost rear fender support hole, fitting the collar on the rear docking point toward the hole.

6. Install the clip nut onto the screw threads from underneath the fender and orient as noted earlier when disassembled. Tighten the screw to 15 ft-lbs (20 Nm).
7. Repeat steps 1 through 6 for the opposite side of the motorcycle.
8. See Figure 3. Obtain four screws (3), two spacers (4), (1/4 in. (6.3 mm) thick) and one spacer (5), (1/8 in. (3.2 mm) thick) from the kit and support arm (C), four lock washers (E) and four flat washers (F) removed earlier.
9. Stack the three spacers with the thinner spacer sandwiched between the two other plastic spacers. Orient the spacer stack relative to the support arm mount plate and against the saddlebag tub.
10. Add a split, lock washer and flat washer to each of the four screws (lock washer against screw head). Coat the last 4 to 6 screw threads with a few drops of Loctite 243 (Blue).
11. Insert the screws from inside the saddlebag, through the spacer stack and into the support arm threaded inserts. Insert and finger thread all four screws prior to tightening the screws. The spacer stack should fit directly against the saddlebag tub back and not pinch the leather upholstery.
12. Torque all four screws to 60-90 in-lbs (6.7-10.2 Nm).
13. Repeat steps 8 through 12 above for the opposite side saddlebag.
14. Mount both saddlebags to the outermost pair of docking points and support arm docking clevis at the passenger footpeg location per instructions provided with the saddlebag kit.

## MAINTENANCE

### NOTE

*In time, the docking points may wear causing the mating accessory to become loose. The fit may be tightened using the following procedure.*

1. Loosen the docking hardware.
2. Rotate the docking points approximately a quarter turn (90°).
3. Tighten the docking hardware to the appropriate torque values as indicated in the installation procedures.

This procedure can be repeated only **once** before replacement of the docking points is recommended.

### NOTE

*IF the co-molded plastic docking point surfaces appear to be cracked or if any piece appears to be missing, replace the docking point immediately. Cracked or missing chunks of the plastic overmold will result in a lot more free play than can be eliminated by rotating the docking points.*

## SERVICE PARTS

is06353

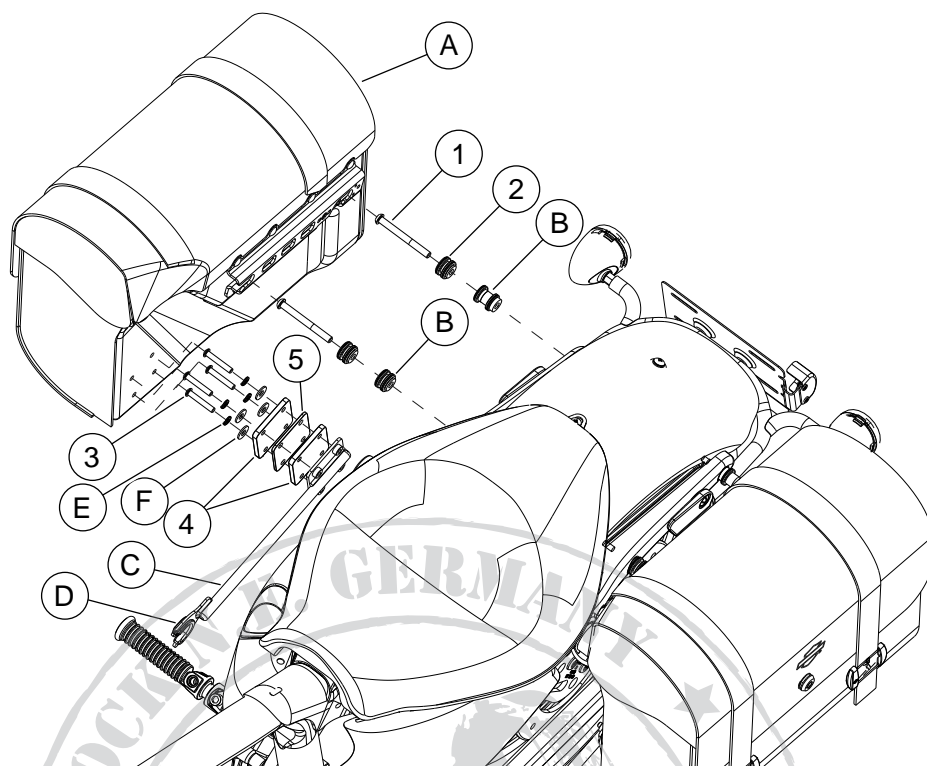

**Figure 3. Service Parts: Docking Hardware**

**Table 1. Service Parts Table**

Item	Description (Quantity)	Part Number
1	Button head cap screw, TORX®, 5/16-18 x 3 in. (4)	Not Sold Separately
2	Docking point (4)	53942-04
3	Button head cap screw, 1/4-20 x 1.50 in. (8)	3088
4	Spacer, 1/4 in. thick, HDPE (4)	Not Sold Separately
5	Spacer, 1/8 in. thick, HDPE (2)	Not Sold Separately
<b>Items mentioned in text, but not included in kit:</b>		
A	Saddlebag assembly, right and left	
B	Docking kit, detachables	53529-04
C	Support arm 3 <sup>rd</sup> point, saddlebag assembly	88359-10
D	Docking clip	52682-09
E	Lock washer, split, 1/4 in.	7036
F	Flat washer, wide, 1/4 in.	6235
G	Flanged locknut, 5/16-18 (see Figure 2, item 6)	7531
H	Clip nut, 5/16-18 (see Figure 2, item 5)	10323