



INSTRUCTIONS

-J04037

REV. 2007-01-04

SADDLEBAG WALL ORGANIZER KIT

GENERAL

Kit Number

88232-06

Models

For model fitment information, please see the P&A Retail Catalog or the Parts and Accessories section of www.harley-davidson.com (English only).

Kit Contents

Table 1. Kit Contents

Description (Quantity)	Part Number
Wall Organizer, Right	Not Sold Separately
Wall Organizer, Left	Not Sold Separately
Flat Washer (4)	6480

INSTALLATION

WARNING

Do not exceed saddlebag weight capacity. Put equal weight in each bag. Too much weight in saddlebags can cause loss of control, which could result in death or serious injury. (00383a)

NOTE

Maximum load capacity of the wall organizer is 2.5 lbs (1.1 Kg). The combined load of wall organizer and saddlebag must not exceed 15 lbs (6.8 Kg).

Saddlebag Without Liners

1. See Figure 1. Open saddlebag.

NOTE

On some HDI motorcycles, the bail wire has been removed from the quick release stud. In these cases, turn the stud by engaging the slotted end with a large screwdriver.

2. See Figure 2. Grasp bail wire (1) inside saddlebag and rotate front bail head stud (2) a full 1/4 turn in a counter-clockwise direction. Remove front bail head stud (2) and flat washer (3). Discard washer but save stud for kit installation.

3. See Figure 3. Place flat washer (1) from kit on front bail head stud.

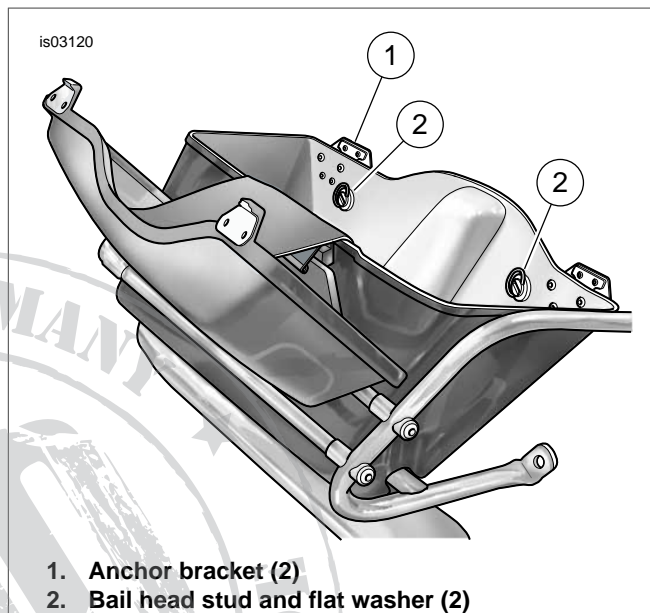

1. Anchor bracket (2)
2. Bail head stud and flat washer (2)

Figure 1. Open/Close Saddlebag

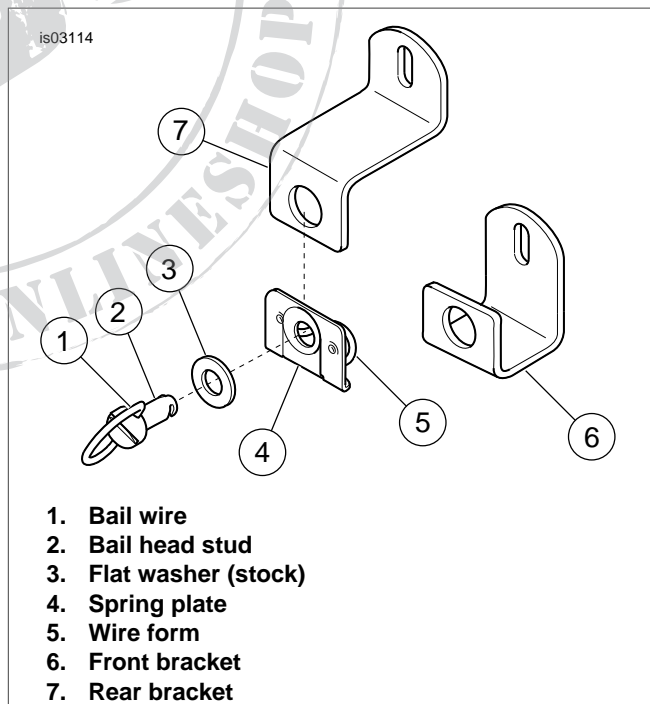

1. Bail wire
2. Bail head stud
3. Flat washer (stock)
4. Spring plate
5. Wire form
6. Front bracket
7. Rear bracket

Figure 2. Saddlebag Quick-Release Fasteners

4. With groove at end of stud held in a horizontal position, insert front bail head stud (2) and flat washer (1) through hole in wall organizer (3), saddlebag, and mounting bracket. When groove engages wire form of spring plate

on inboard side of bracket, turn stud clockwise a full 1/4 turn until it snaps in place.

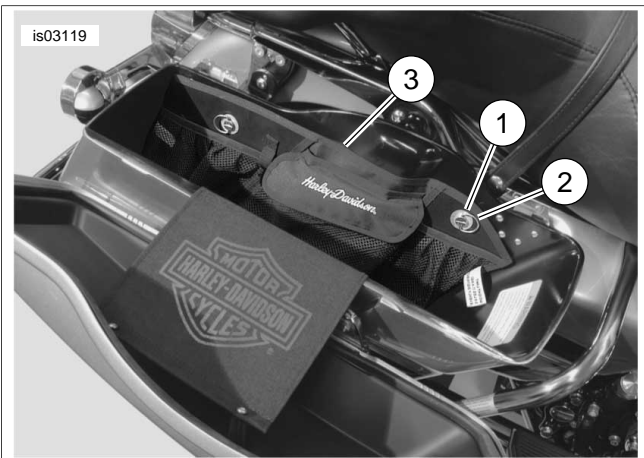

1. Flat washer (2)
2. Bail head stud (2)
3. Saddlebag wall organizer

Figure 3. Install Saddlebag Wall Organizer (Without Liners)

5. Repeat Steps 2 through 4 for rear bail head stud.
6. See Figure 1. Close saddlebag.
7. Repeat procedure for opposite saddlebag.

Saddlebag With Liners

1. See Figure 1. Open saddlebag.

NOTE

On some HDI motorcycles, the bail wire has been removed from the quick release stud. In these cases, turn the stud by engaging the slotted end with a large screwdriver.

2. See Figure 2. Grasp bail wire (1) inside saddlebag and rotate front and rear bail head studs (2) a full 1/4 turn in a counterclockwise direction. Remove bail head studs and flat washers (3). Discard washers but save studs for kit installation.
3. Remove saddlebag and place on flat working surface.
4. Remove liner from saddlebag.
5. See Figure 4. Remove front and rear grommets from saddlebag. For best results, pinch grommet on saddlebag inside and pull grommet out from saddlebag outside.

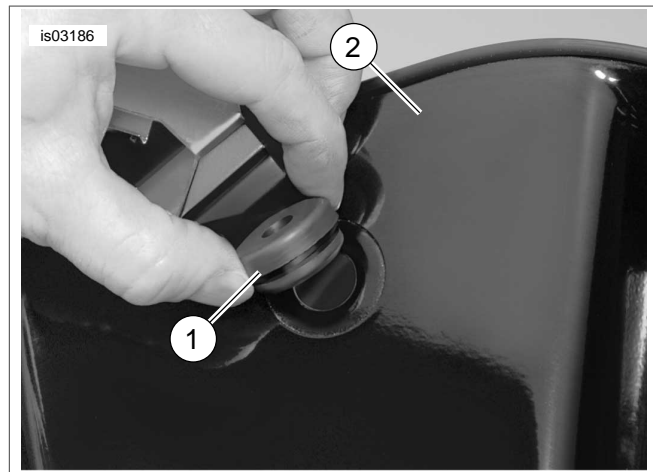

1. Grommet (2)
2. Saddlebag outside

Figure 4. Remove Front and Rear Grommets

6. Moisten grommet with glass cleaner or soapy water.
7. See Figure 5. Install front and rear grommets on saddlebag. Grommets are installed backwards from original equipment. Ensure grommets are fully installed on before continuing to install kit. For best results, apply firm pressure to grommet on saddlebag inside and rotate into place.

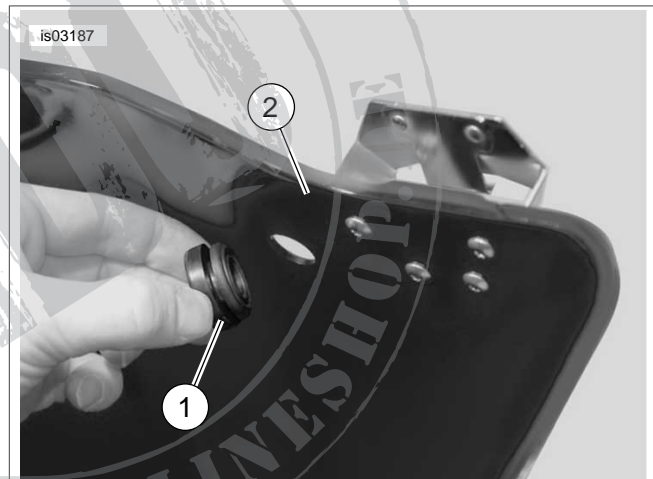

1. Grommet (2)
2. Saddlebag inside

Figure 5. Install Front and Rear Grommets

8. Place saddlebag into position on motorcycle.
9. See Figure 6. Place liner into saddlebag. Ensure liner is properly seated inside saddlebag and holes in liner are positioned over grommets.

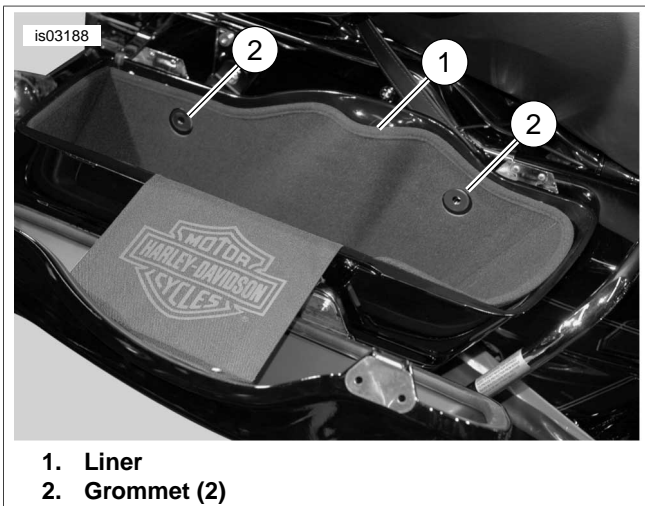

Figure 6. Placement of Liner Inside Saddlebag

10. See Figure 7. Place flat washer (1) from kit on front bail head stud.
11. With groove at end of stud held in a horizontal position, insert front bail head stud (2) and flat washer (1) through hole in wall organizer (3), liner (4), saddlebag, and mounting bracket. When groove engages wire form of spring plate on inboard side of bracket, turn stud clockwise a full 1/4 turn until it snaps in place.
12. Repeat Steps 10 and 11 for rear bail head stud.

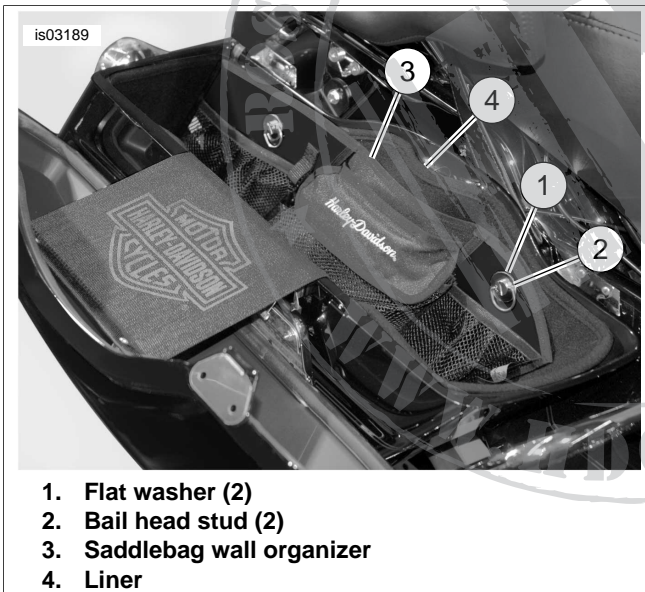

Figure 7. Install Saddlebag Wall Organizer (With Liner)

13. See Figure 1. Close saddlebag.
14. Repeat procedure for opposite saddlebag.

Saddlebag Mounting Adjustment

1. See Figure 8. Molded rubber insert at bottom of saddlebag must fit snugly on lower saddlebag support rail. If saddlebag is not fully seated, use an open end/box wrench to loosen bolts (1) and (2) securing mounting brackets to saddlebag support and frame.
2. Alternately tighten bolts to 60-96 **in-lbs** (7-11 Nm) after seating saddlebag.

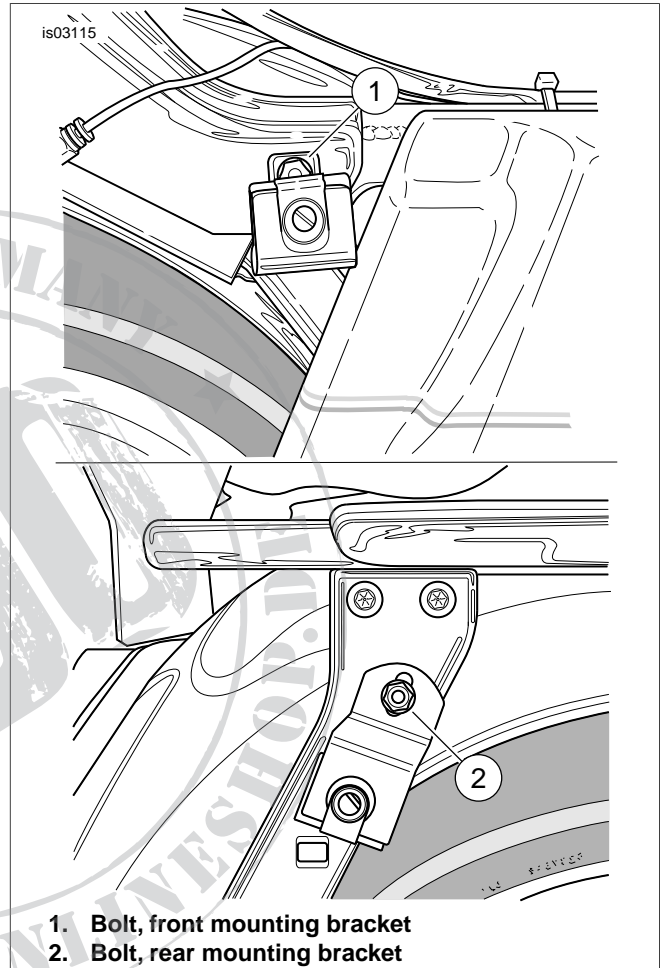

Figure 8. Saddlebag Mounting Bracket Bolts (right side shown)