



# INSTRUCTIONS

-J05157

REV. 2010-06-07

## TRIKE SADDLEBAGS

### GENERAL

#### Kit Number

84031-11

#### Models

For model fitment information, see the P&A Retail Catalog or the Parts and Accessories section of [www.harley-davidson.com](http://www.harley-davidson.com) (English only).

#### Additional Parts Required

13/32 inch (10.31 mm) drill bit

9/32 inch (7.14 mm) drill bit

Masking tape

### WARNING

**The rider's safety depends upon the correct installation of this kit. Use the appropriate service manual procedures. If the procedure is not within your capabilities or you do not have the correct tools, have a Harley-Davidson dealer perform the installation. Improper installation of this kit could result in death or serious injury. (00333a)**

#### Kit Contents

See Figure 2 and Table 1.

### INSTALLATION

- Carefully cut out the templates that come with the kit. The template marked "Left" will be used on the left side of the body if you are sitting on the Trike.
- See Figure 1. Line up the right (short) side of the template with the fender and the body contour bend as shown in Figure 1. Tape the top of the template to the body. Using a sharp center punch, mark the center of the two target circles.
- Remove the template and place a two inch strip of masking tape over the area of the punch marks to prevent cracking the paint when drilling.
- Locate the punch marks and using a 13/32 inch (10.31 mm) drill bit, carefully drill two holes through the center punch marks. Check to confirm if the screws fit through the drilled holes.
- See Figure 2. Install the two docking points (1) to the two screws (2) and install to the drilled holes and fasten with washers (3) and nuts (4).
- Place masking tape on the Trike body in the area of the Trike saddlebag upper bracket.
- Install the saddlebag to the docking points.
- Place the center punch through the grommet in the upper mounting bracket and make a center punch in the body.
- Remove the saddlebag.
- Drill a 13/32 inch (10.31 mm) hole through the Trike body.
- Center the quarter turn plate hole horizontally over the top hole just drilled and make punch marks through the two pem nuts on the turn plate.
- Drill 9/32 inch (7.14 mm) holes for the pem nut locations.
- Install the stud receptacle (10) to quarter turn plate (6) by sliding it over the quarter turn plate with the wire side on the side with the pem nuts.
- Install quarter turn plate with the flat side to the underside of the body and fasten with screws (7).
- Install the saddlebag to the docking points.
- Lock the upper mounting bracket to the Trike body using the bail head stud (9) and washer (8).
- Repeat steps 2 through 15 for the opposite side.

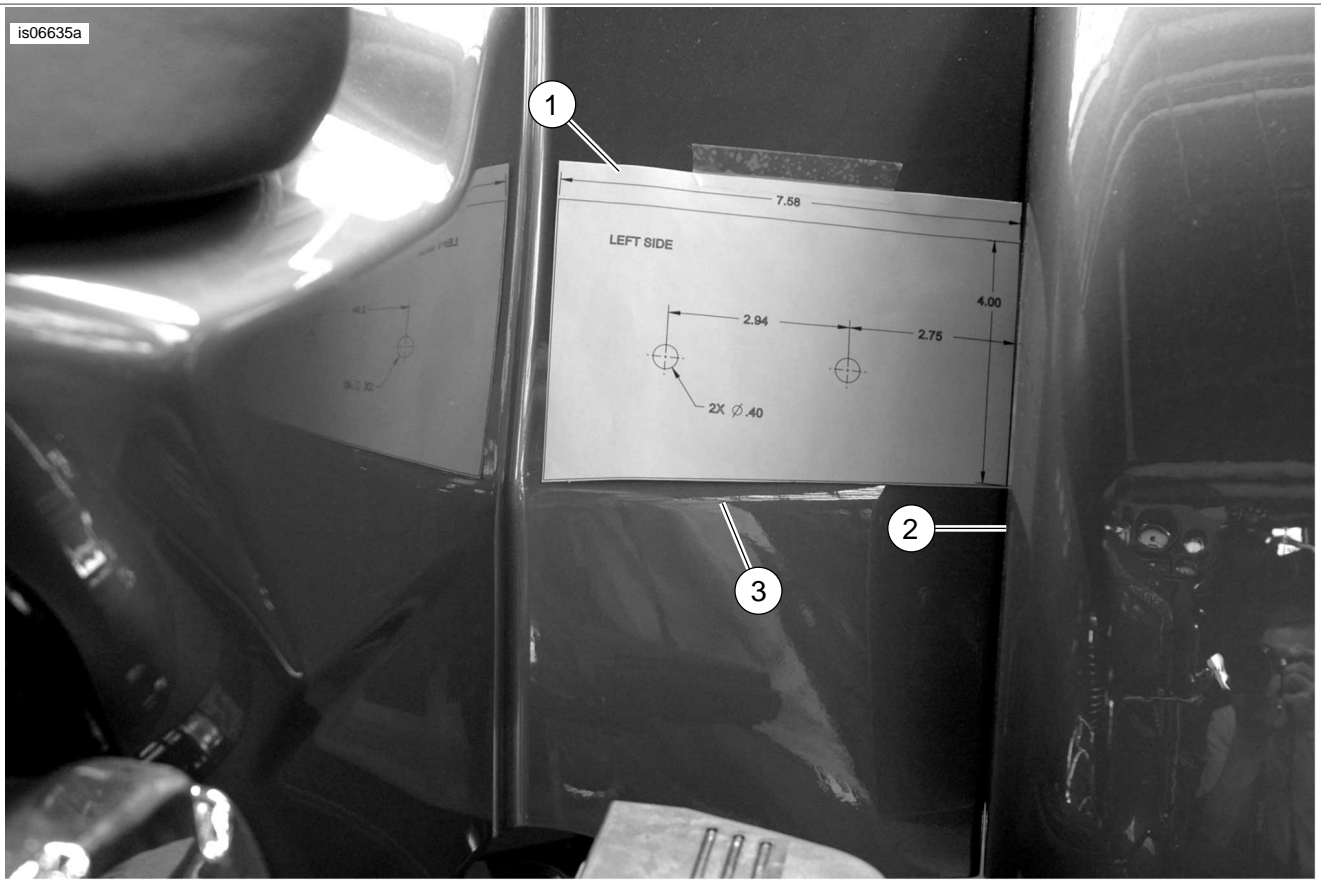

- 1. Left side template
- 2. Fender side
- 3. Lower body contour bend

Figure 1. Template on Left Side Body

## SERVICE PARTS

is06618a

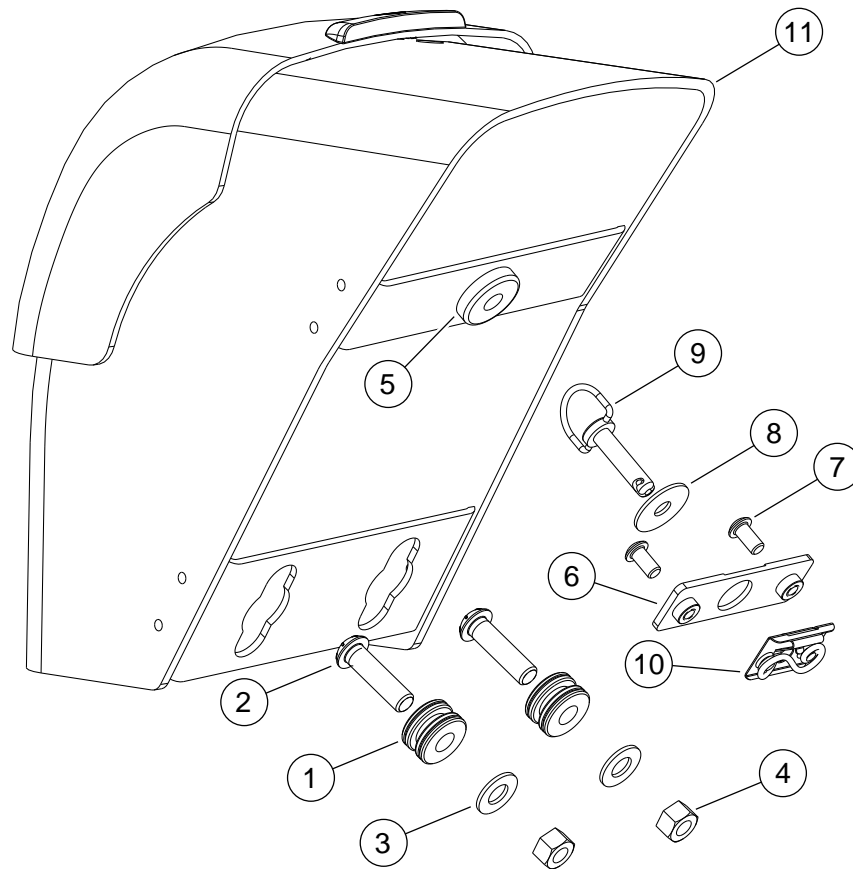

**Figure 2. Service Parts: Trike Saddlebag Mounting Hardware**

**Table 1. Service Parts**

Item	Description (Quantity)	Part Number
1	Docking point, mini (2)	53967-06
2	Button head hex bolt, 0.375-16 x 1.375 (2)	4103
3	Plain washer, type A (2)	6701
4	Hex nut (2)	7783
5	Grommet	11464
6	Quarter turn plate, w/PEM® fasteners	Not Sold Separately
7	Hex socket button head screws (2)	4365
8	Washer	6229W
9	Bail head stud	10900002
10	Stud receptacle	70909-95
11	Trike saddlebag, right	84072-11
12	Trike saddlebag, left	84032-11
12	Template	93300013