



# INSTRUCTIONS

-J04747

REV. 2008-06-20

## AM/FM ANTENNA KIT (TOUR-PAK MOUNT)

### GENERAL

#### Kit Number

76251-98A

#### Models

For model fitment information, see the P&A Retail Catalog or the Parts and Accessories section of [www.harley-davidson.com](http://www.harley-davidson.com) (English only).

#### Additional Parts Required

Prior installation of a Radio Kit and a Tour-Pak® is required. See a Harley-Davidson dealer for availability of color-matched King or Chopped Tour-Paks to match your vehicle and additional items that may be required when mounting the radio and Tour-Pak to your model.

### WARNING

The rider's safety depends upon the correct installation of this kit. Use the appropriate service manual procedures. If the procedure is not within your capabilities or you do not have the correct tools, have a Harley-Davidson dealer perform the installation. Improper installation of this kit could result in death or serious injury. (00333a)

#### NOTE

This instruction sheet references service manual information. A service manual for your model motorcycle is required for this installation and is available from a Harley-Davidson Dealer.

#### Kit Contents

See Figure 4 and Table 1.

### INSTALLATION

#### NOTE

Harley-Davidson strongly recommends that the antenna be installed where indicated. In this position the antenna will cause the least interference with the opening and closing of the Tour-Pak lid.

#### Tour-Pak Preparation

1. Refer to the service manual and follow the instructions to remove the left side saddlebag.
2. Open the Tour-Pak lid and remove all items from the Tour-Pak base.
3. **Models with rubber mat:** Remove the mat.  
**Models with molded liner:** Open the map pocket and remove the acorn nuts and flat washers. Remove the map pocket and liner.

### WARNING

To prevent accidental vehicle start-up, which could cause death or serious injury, remove main fuse before proceeding. (00251b)

4. Remove the main fuse following the instructions in the service manual.
5. See Figure 1. Measure and determine the center (1) of the outside rear Tour-Pak wall.

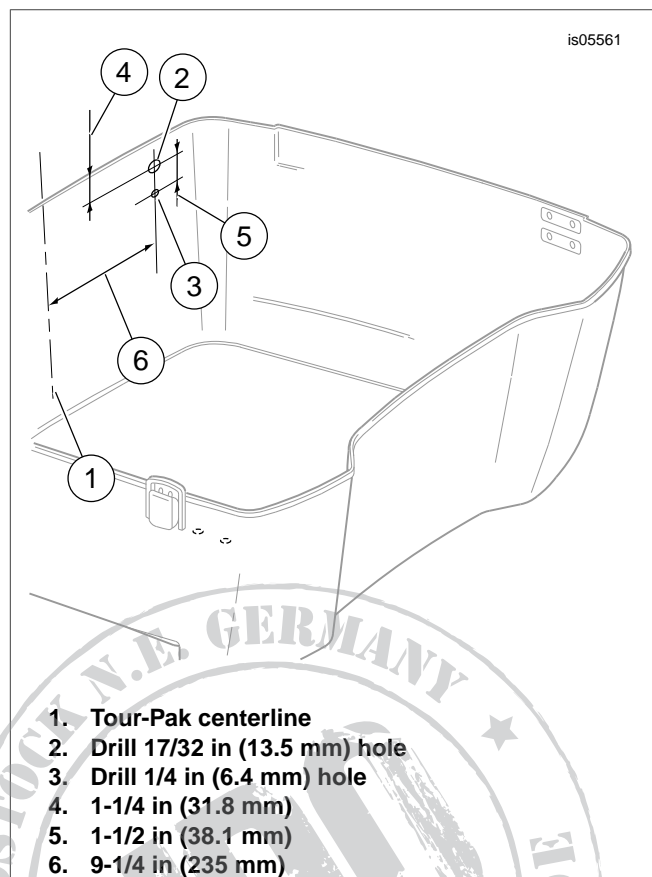

Figure 1. Tour-Pak AM/FM Antenna Drilling Location

6. Lay a strip of 2 in (51 mm) wide masking tape from top to bottom over the approximate center of the outside rear Tour-Pak wall.
7. Measure again and mark the center near the top of the tape strip. Measure and mark the center near the bottom of the strip. Draw a line from the top mark to the bottom mark.
8. Facing the tape, measure 9-1/4 in (235 mm) from the center line to the left side of the outside rear Tour-Pak wall.

9. Lay a strip of 2 in (51 mm) wide masking tape from the top to approximately half-way down the outside rear Tour-Pak wall at the 9-1/4 in (235 mm) distance from the center line.
10. Measure again and mark the tape 9-1/4 in (235 mm) (6) from the center line near the top of the tape strip and again near the bottom of the strip. Draw a line from the top mark to the bottom mark.
11. Measure down 1-1/4 in (31.8 mm) (4) from the top edge of the Tour-Pak on the left side vertical line and draw a short horizontal line (2) across the vertical line.
12. Measure down 1-1/2 in (38.1 mm) (5) from the **first** horizontal line and draw another short horizontal line (3) across the vertical line.
13. Mark the center of the crossed lines with a center punch, then:
  - a. Drill two 1/8 in (3 mm) guide holes through the Tour-Pak wall.
  - b. Drill a 17/32 in (13.5 mm) hole (2) through the **upper** guide hole.
  - c. Drill a 1/4 in (6.4 mm) hole (3) through the **lower** guide hole.
14. Remove the tape. Lightly sand to remove burrs and sharp edges. Clean the Tour-Pak surface of tape residue with a mixture of 50-70% isopropyl alcohol and 30-50% distilled water.

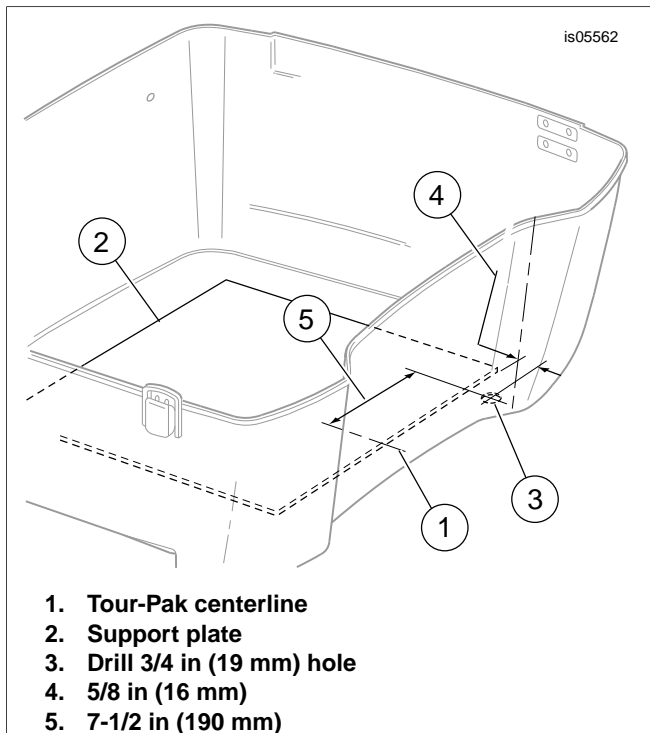

Figure 2. AM/FM Antenna Cable Drilling Location (Type 1 Tour-Pak)

15. **If the Tour-Pak IS NOT drilled for wiring at the lower left forward edge and if the Tour-Pak interior has a MEDIUM GRAY, GLOSSY finish (Type 1 Tour-Pak):**
  - a. See Figure 2. Measure and determine the center (1) of the support plate (2) that covers the floor of the Tour-Pak.
  - b. Lay a strip of 2 in (51 mm) wide masking tape from the front to about half-way back down the approximate center of the support plate.
  - c. Measure again and mark the center of the support plate (2) at the front of the tape strip, and again near the back. Draw a straight line through the two marks.
  - d. Facing the tape, measure 7-1/2 in (190 mm) (5) from the center line to the left side floor of the Tour-Pak.
  - e. Lay a strip of 2 in (51 mm) wide masking tape on the Tour-Pak floor in front of the support plate at the 7-1/2 in (190 mm) distance from the center line, from the support plate to the front wall.
  - f. Measure again and mark the tape 7-1/2 in (190 mm) from the center line, near the front wall and again near the support plate. Draw a line between the two marks.
  - g. Measure forward 5/8 in (16 mm) (4) from the front edge of the support plate, and draw a short line across the line drawn in the step above.
  - h. Mark the center of the crossed lines with a center punch, then drill a 1/8 in (3 mm) guide hole through the Tour-Pak floor.
  - i. Lay a strip of 2 in (51 mm) wide masking tape on the outer surface of the Tour-Pak floor, centered on the guide hole. Cut a hole in the tape at the guide hole.
  - j. From the underside of the Tour Pak drill a 3/4 in (19 mm) hole (3) from the outside of the Tour-Pak to the inside.
  - k. Remove the tape. Lightly sand to remove burrs and sharp edges. Clean the inside and outside Tour-Pak surfaces of tape residue with a mixture of 50-70% isopropyl alcohol and 30-50% distilled water.



**If the Tour-Pak interior has a MATTE BLACK finish (Type 2 Tour-Pak):**

- a. See Figure 3. Measure and determine the center (1) of the inside front Tour-Pak wall.
- b. Lay a strip of 2 in (51 mm) wide masking tape from top to bottom over the approximate center of the inside front Tour-Pak wall.
- c. Measure again, and mark the center near the top of the tape strip. Measure and mark the center near the bottom of the strip. Draw a line from the top mark to the bottom mark.
- d. Facing the tape, measure 6-3/8 in (162 mm) from the center line to the left side front Tour-Pak wall. Do not follow the curve of the wall, but measure **straight across**. See Figure 3 inset.
- e. Lay a strip of 2 in (51 mm) wide masking tape from the bottom to approximately half way up the inside front Tour-Pak wall at the 6-3/8 in (162 mm) distance from the center line.
- f. Measure again and mark the tape 6-3/8 in (162 mm) (5) **straight across** from the center line, near the top of the tape strip and again near the bottom of the strip. Draw a line from the top mark to the bottom mark.
- g. **For King Tour-Pak:** Measure down 7-19/32 in (193 mm) (3) from the top edge of the Tour-Pak.  
**For Chopped Tour-Pak:** Measure down 4-19/32 in (117 mm) (3) from the top edge of the Tour-Pak.  
Draw a short horizontal line across the vertical line.
- h. Mark the center of the crossed lines with a center punch, then drill a 1/8 in (3 mm) guide hole through the Tour-Pak front wall.
- i. Lay a strip of masking tape on the outer surface of the Tour-Pak front wall, centered on the guide hole. Cut a hole in the tape at the guide hole.
- j. From the outside of the Tour Pak drill a 3/4 in (19 mm) hole (4) through the guide hole to the inside.
- k. Remove the tape. Lightly sand to remove burrs and sharp edges. Clean the inside and outside Tour-Pak surfaces of tape residue with a mixture of 50-70% isopropyl alcohol and 30-50% distilled water.

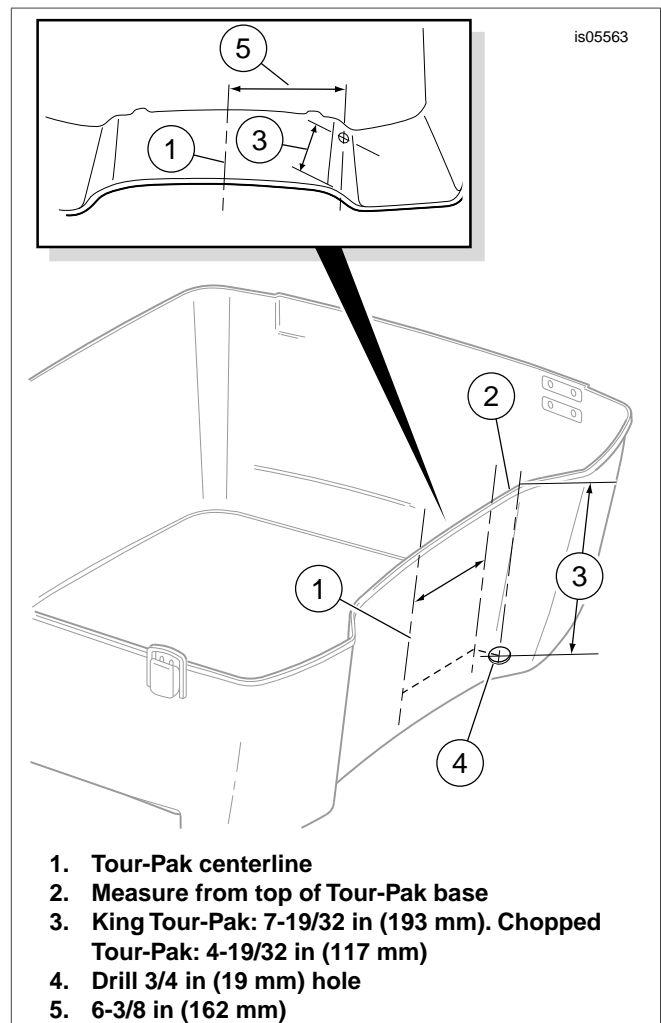

**Figure 3. AM/FM antenna Cable Drilling Location (Type 2 Tour-Pak)**

### Antenna Mounting

16. See Figure 4. Obtain the antenna base assembly (2) from the kit. Remove the hex nut (7) and internal tooth lockwasher (6) from the plug assembly (5) on the base.
17. Assemble the base gasket (8) to the antenna base.
18. With the antenna mast stud (1) facing **up**, position the base assembly over the holes drilled earlier in the outside rear Tour-Pak wall. Be sure the plug assembly (5) goes through the larger (top) hole.
19. Place the antenna reinforcement plate (9) in position inside the Tour-Pak. Obtain the ground cable (12) from the kit, and place the large ring terminal over the plug assembly. Use the hex nut (7) and lockwasher (6) to attach the ground cable to the plug assembly, but do not fully tighten at this time.

20. Attach the other end of the ground cable to one of the mounting screws on the floor of the Tour-Pak.
  - a. While holding the screw head, remove the nylon cap locknut, washer and spacer on the underside that fasten the Tour-Pak to the luggage rack side rail.
  - b. Remove the screw and flat washer from the hole and install the small ring terminal of the ground cable onto the screw threads. Install the screw back into the hole.
  - c. On the underside of the luggage rack, install the spacer (concave side up), flat washer and nylon cap locknut on the screw. With the spacer concavity in line with the luggage rack rail, hold the nut and tighten the screw to 96-120 **in-lbs** (10.8-13.5 Nm).
21. Install the TORX® screw (10) and small lockwasher (11) through the smaller (bottom) hole of the antenna reinforcement plate into the antenna base. Tighten the screw securely. Tighten the hex nut securely.
22. Thread the antenna mast assembly (1) onto the antenna base adapter.

### Antenna Connection

#### NOTE

*The antenna cable is attached to the frame member at the factory to protect it from damage until it is connected to the antenna.*

23. Refer to the service manual and follow the instructions given to remove the left side cover. Locate the coiled or bundled antenna cable (attached to the frame with a cable strap).
24. Cut the cable strap holding the antenna cable.
25. Route the antenna cable rearward to the front luggage rack mount, then along the inside of the luggage rack and up through the hole in the left front bottom of the Tour-Pak.
26. Plug the antenna cable connector into the antenna base.

27. Tighten the knurled nut to secure the connector to the antenna base.
28. Make sure enough cable has been routed into the Tour-Pak so that the cable rests flat on the bottom of the Tour-Pak. Use cable straps (14) to secure the antenna cable to the Tour-Pak support as needed.
29. Install the grommet (13) onto the antenna cable near the hole in the Tour-Pak. Carefully work the grommet into the hole to seal the opening around the cable.
30. Install the rubber mat or molded liner. Close the Tour-Pak lid.
31. Remove the outer fairing and windshield. Refer to the service manual.

#### NOTE

*To prevent possible damage to the sound system, verify that the ignition/light key switch is in the OFF position.*

32. Locate the front end of the antenna cable (attached to the main harness with tape). Cut the tape holding the antenna cable.
33. Route the antenna cable over to the radio.
34. Plug the antenna cable connector into the back of the radio.
35. Tighten the knurled nut to secure the connector to the radio.
36. Use cable straps from the kit to fasten the antenna cable to the existing harnesses inside the fairing.
37. Install the main fuse.
38. Turn the ignition/light key switch to the ACCESS position.
39. Test the radio for proper operation.
40. Install the outer fairing and windshield. Refer to the service manual.



## SERVICE PARTS

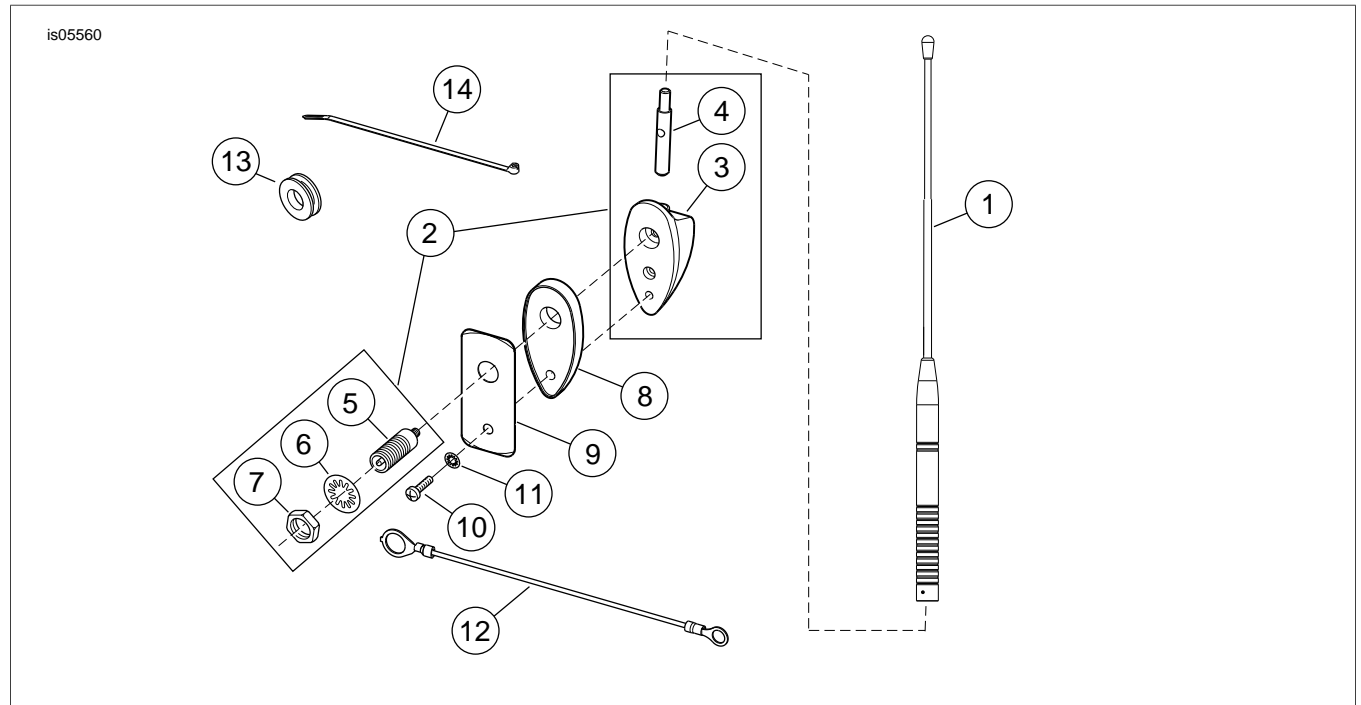

Figure 4. Service Parts: AM/FM Tour-Pak Mount Antenna

Table 1. Service Parts Table

Item	Description (Quantity)	Part Number
1	Mast assembly, antenna	76503-08
2	Antenna base assembly (includes items 3 through 7)	76252-86
3	• Base, antenna	Not Sold Separately
4	• Adapter, antenna	Not Sold Separately
5	• Plug assembly	76258-86
6	• Lockwasher, internal tooth, 1/2 in.	7129
7	• Hex jam nut, 1/2-20	76259-86
8	Gasket, antenna base	76255-86
9	Reinforcement plate	76253-86
10	Machine screw, pan head, TORX	2576
11	Lockwasher, internal tooth, #10	7118
12	Ground cable, AM/ FM antenna	70465-86A
13	Grommet	11486
14	Cable strap (10)	10006