



INSTRUCTIONS

-J04433

REV. 2007-04-23

AM/FM ANTENNA RELOCATION KIT

GENERAL

Kit Number

76208-07

Models

This kit fits 2006 and later FLHX (Street Glide®) and 1997 and later FLTR (Road Glide®) models equipped with Detachable Two-Up Luggage Rack (Part Number 53743-97) and Two-Up Touring Detachable Docking Hardware Kit (Part Number 53804-06).

Kit Contents

See Figure 2 and Table 1.

INSTALLATION

1. Refer to the Owner's Manual and follow the instructions given to remove the **left-side** saddlebag. Gently pull the left-side cover from the frame downtubes (no tools are required), and remove the Maxi® Fuse.
2. See Figure 1. Disconnect the antenna cable from the antenna base assembly (1).

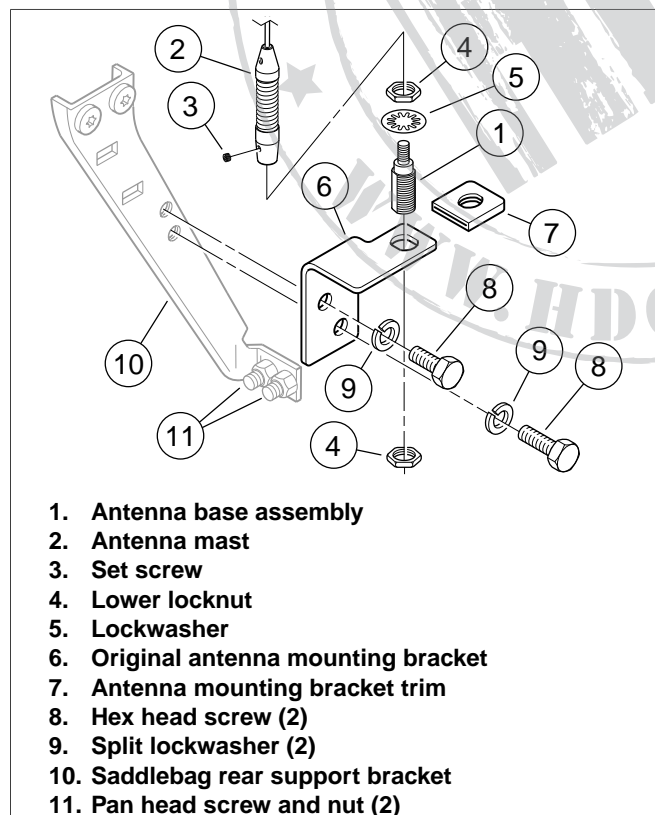

Figure 1. Original Antenna Mount

3. Use a 2 mm hex key to loosen the bottom set screw (3) of the antenna mast (2). Unscrew the mast from the antenna base, and set it aside for re-installation.
4. Remove the lower locknut (4), and remove the antenna base from the mounting bracket (6). Save both locknuts, but discard the lockwasher (5).
5. Remove the two screws (8) and lockwashers (9) retaining the antenna mounting bracket and trim (7) to the saddlebag rear support bracket (10). Discard the bracket, trim and fasteners.
6. Carefully remove and discard any cable straps securing the antenna cable to the fender support and saddlebag rear support brackets.
7. Support the left-side muffler in the installed position with a wood block or other suitable method. Remove and discard the two pan head screws and nuts (11) that fasten the lower saddlebag support bar to the saddlebag rear support bracket.
8. See Figure 2. Obtain the **new** antenna bracket (1), and two button head screws (2), flat washers (3) and flange nuts (4) from the kit. Assemble a flat washer to the threads of each screw.
9. Position the antenna bracket as shown to the forward side of the lower saddlebag support bar (C). From the rear, insert the threads of one screw through the saddlebag-to-fender support bracket (A), and the inboard hole in the saddlebag rear support bracket (B) and saddlebag support bar. Insert the remaining screw through the outboard hole in the support bracket and bar.
10. Thread a flange nut onto the threads of each bolt. Tighten to 18 ft-lbs (24 Nm).
11. Place the internal tooth lockwasher (5) from the kit onto the larger threads of the antenna base (D, removed earlier), under the hex nut (E), and insert the antenna base through the hole in the antenna mounting bracket.
12. Install the second hex nut (F) onto the threads of the antenna base. Place a wrench on the upper nut and tighten the lower nut to 6 ft-lbs (8 Nm).
13. Locate the coiled or bundled excess antenna cable attached to the frame member (under the left-side cover) with a cable strap. Remove the cable straps retaining the antenna cable to the rear, and feed the excess cable rearward as needed to easily reach the new antenna location and provide sufficient slack at the antenna base to avoid kinking or binding at the connection.

NOTE

The antenna cable should be routed rearward to the front luggage rack mount, then along the inside of the luggage rack and down the front of the saddlebag rear support bracket, over to the underside of the new antenna bracket. Correct the routing if different.

14. Plug the antenna cable connector into the antenna base. Tighten the knurled nut to secure the connector to the antenna base. Allow slack in the cable at the antenna base to avoid kinking or binding at the connection.
15. Fasten the antenna cable to the saddlebag rear support bracket at the rectangular hole with a cable strap (6) from the kit.

Use a second cable strap to tie the antenna cable (**and on FLHX models, the excess rear fascia lamp wires**) to the frame rail, near the suspension air lines, underneath the chrome cover. DO NOT tie the cable to the air lines.

Use the remaining cable strap to tie the antenna cable (J) to the saddlebag-to-fender support (A) and saddlebag rear support (B) brackets as shown.

16. Thread the antenna mast assembly (G) onto the antenna base (D), and use a 2 mm hex key to securely tighten the set screw (H) at the bottom of the mast assembly to hold it in place.

NOTE

To prevent possible damage to the sound system, verify that the Ignition/ Light Key Switch is in the OFF position before re-installing the maxi-fuse.

17. Verify that the Ignition/Light Key Switch is in the OFF position. Refer to the Owner's Manual and follow the instructions given to re-install the maxi-fuse.
18. Test the radio for proper operation.
19. Re-install the left-side cover and saddlebag.



SERVICE PARTS

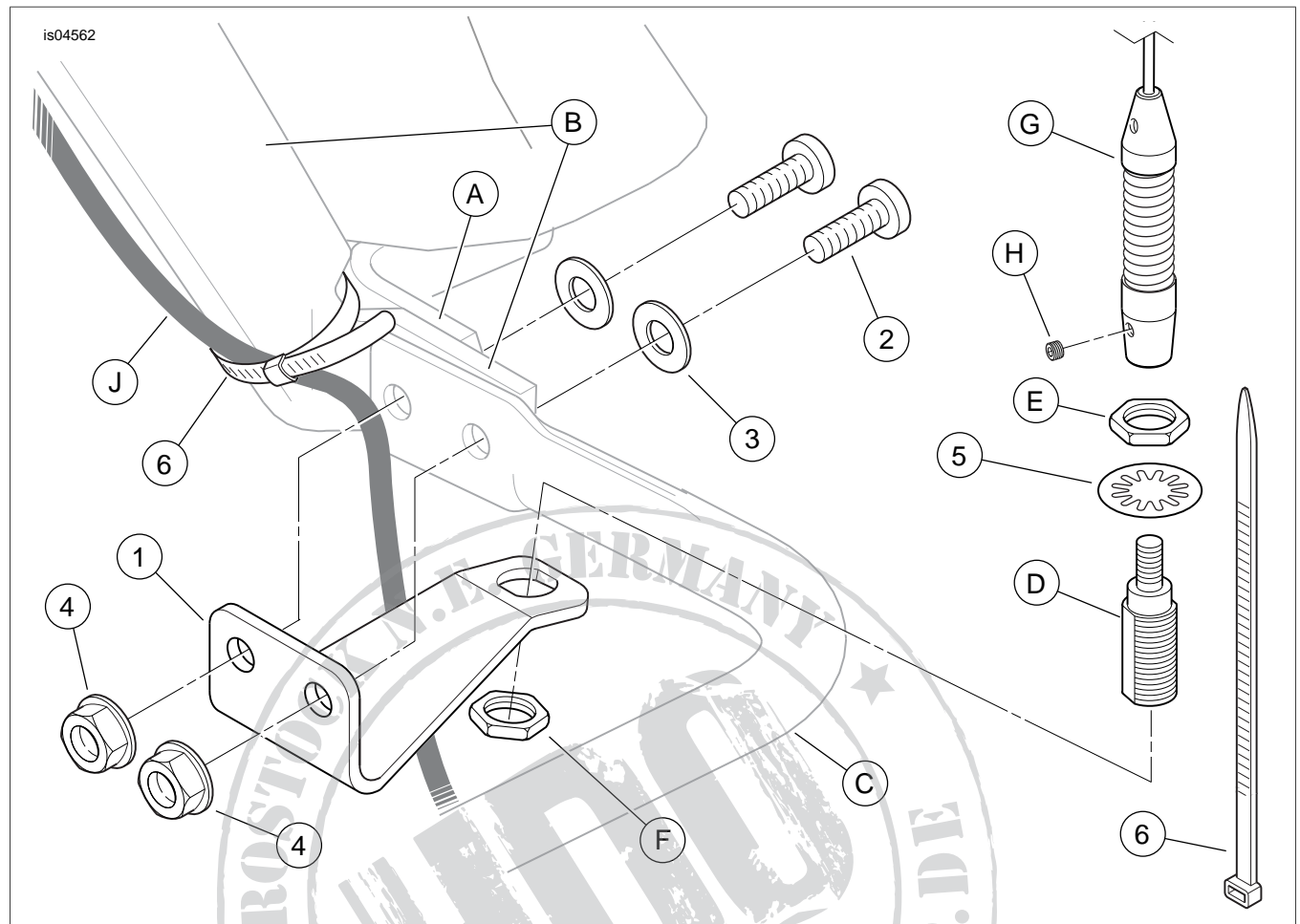

Figure 2. Service Parts, Antenna Relocation Kit

Table 1. Service Parts Table

Item	Description (Quantity)	Part Number
1	Bracket, antenna mounting	Not sold separately
2	Screw, hex socket, button head, 5/16-18 x 1-1/4 inch long (2)	4334
3	Washer, flat (2)	6702
4	Hex flange nut, 5/16-18 (2)	7531
5	Lockwasher, internal tooth, 1/2 inch	7129
6	Cable strap (3)	10006
Items mentioned in text, but not included in kit:		
A	Saddlebag-to-fender support bracket	
B	Saddlebag rear support bracket	
C	Lower saddlebag support bar	
D	Antenna base	
E	Upper antenna base hex nut	
F	Lower antenna base hex nut	
G	Antenna mast assembly	
H	Lower antenna mast set screw	
J	Antenna cable	