



INSTRUCTIONS

-J06024

2015-06-15

BOOM! AUDIO AMPLIFIER KIT

GENERAL

Kit Number

76000523

Models

For model fitment information, see the P&A retail catalog or the Parts and Accessories section of www.harley-davidson.com (English only).

Installation Requirements

When adding more than four speakers, separate purchase of a speaker expansion kit (Part No. 76000280) is required.

The purchase of this kit entitles you to a specially developed sound equalization software that is used with the Advanced Audio System. This unique equalization was designed to optimize the performance and sound response of the BOOM! Audio fairing lower speakers.

Even if this kit is not installed by a Harley-Davidson dealer, this special equalization software is available without charge from any dealer through Digital Technician II. Dealer labor rates could apply for the upgrade procedure.

⚠ WARNING

The rider's safety depends upon the correct installation of this kit. Use the appropriate service manual procedures. If the procedure is not within your capabilities or you do not have the correct tools, have a Harley-Davidson dealer perform the installation. Improper installation of this kit could result in death or serious injury. (00333a)

NOTE

This instruction sheet refers to service manual information. A service manual for this year/model motorcycle is required for this installation. One is available from a Harley-Davidson dealer.

Electrical Overload

NOTICE

It is possible to overload your vehicle's charging system by adding too many electrical accessories. If the combined electrical accessories operating at any one time consume more electrical current than the vehicle's charging system can produce, the electrical consumption can discharge the battery and cause damage to the vehicle's electrical system. See an authorized Harley-Davidson dealer for advice about the amount of current consumed by additional electrical accessories or for necessary wiring changes. (00211c)

⚠ WARNING

When installing any electrical accessory, be certain not to exceed the maximum amperage rating of the fuse or circuit breaker protecting the affected circuit being modified. Exceeding the maximum amperage can lead to electrical failures, which could result in death or serious injury. (00310a)

This amplifier requires up to **8 amps** more current from the electrical system.

Kit Contents

See Figure 7 and Table 4.

Preparation

⚠ WARNING

To prevent accidental vehicle start-up, which could cause death or serious injury, remove main fuse before proceeding. (00251b)

NOTE

- **Vehicles WITH security siren:** With security fob present, turn ignition switch ON. See the service manual. Disarm security system. **IMMEDIATELY** remove the main fuse.
 - **Vehicles WITHOUT security siren:** See the service manual. Remove main fuse.
1. See the service manual. Remove the seat, fuel tank, outer fairing and air duct.
 2. See Figure 1. Remove the wire trough cover.
 3. See the service manual. Remove the headlamp assembly.



Figure 1. Wire Trough

Installation

1. See Figure 7. Get the front (2) and rear (3) amplifier brackets and four hex socket screws (4) from the kit.

2. See Figure 2. Install the amplifier brackets to the amplifier (1). Tighten the screws to 9–12 N·m (7–9 ft-lbs).

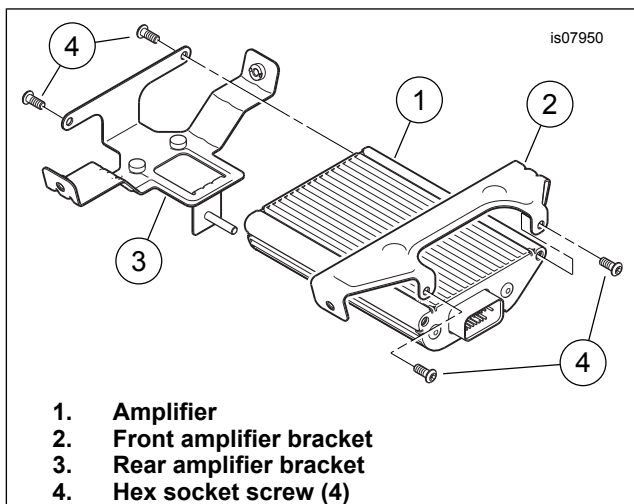

Figure 2. Install Amplifier Mounting Brackets

3. See Figure 3. Install the amplifier.
 - a. Get the four hex head screws (4) and flat washers (5) from the kit.
 - b. Slide the amplifier and bracket assembly (1) into location on the underside of the radio mounting bracket (3) as shown, with the connector (2) facing out. **NOTE: Radio removed to show detail.**
 - c. Align the holes in the radio bracket with the amplifier bracket inserts.

NOTE

The stud on the rear of the bracket is for CVO use only.

NOTE

Electrical connectors are identified in the service manual by the numbers and letters shown here **within brackets**.

- d. Install amplifier to radio bracket with screws and washers. Tighten to 9.5–12.2 N·m (7–9 ft-lbs).

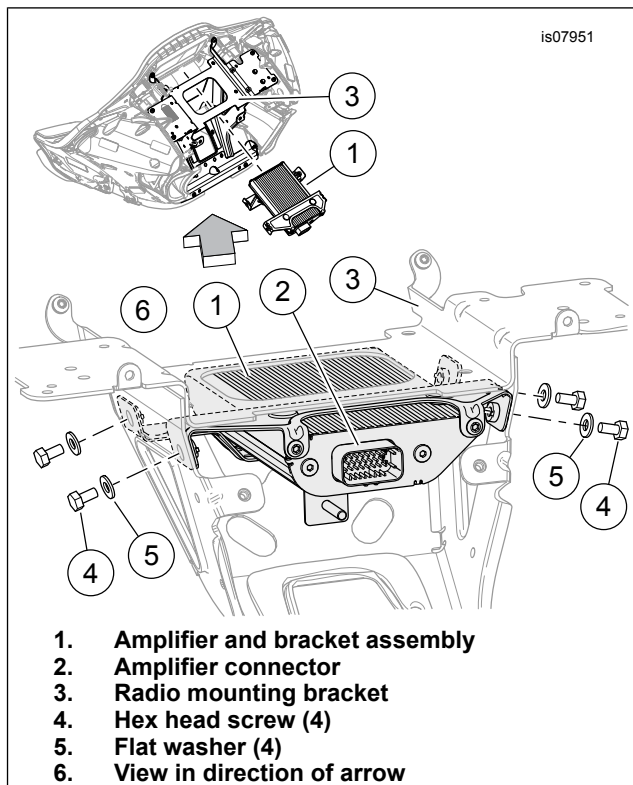

Figure 3. Amplifier Installation

4. See Figure 4. Position the harness as shown. Plug in the connectors. Connections for [34], [35], [162], [313], [299] and [22] are detailed in the following notes.

NOTE

- **FLTRX models:** If adding this amplifier to speakers from a previous installation, see Table 3 for specific instructions regarding wire harness connections.
 - When using this amplifier with a second amplifier to **enable six or eight speakers**, see connector [162] and [313] details in Table 1, Table 2 and Kit 76000280.
 - Four-way Molex connector [162] provides rear channel output from the radio. Used for speaker output on models without amplifier (see Figure 4). Unused with primary amp. Used for secondary amp INPUT.
 - Four-way Molex connector [313] provides rear channel output from the primary amplifier. This connector can be used for saddlebag speakers, rear pods or fairing lowers. When used with six or eight speaker configurations, connector [313] is reserved for fairing lowers.
 - Locate unused two-way Multilock P&A accessory connector [299A], next to the radio on the right (brake lever) side. Remove the socket housing now installed as a cover. Plug main amplifier wire harness connector [299] into the P&A accessory connector.
 - Locate four-way P&A CAN connector [243] next to the left speaker. Disconnect the CAN jumper [243B] from pin housing [243A]. Plug the two halves of four-way connector [22] into the mating halves of connector [243].
5. Unplug the two halves of upper fairing speaker connectors [34] and [35] on the fairing harness. Plug the amplifier wire harness connectors [34] and [35] into both halves of the open fairing harness connectors.

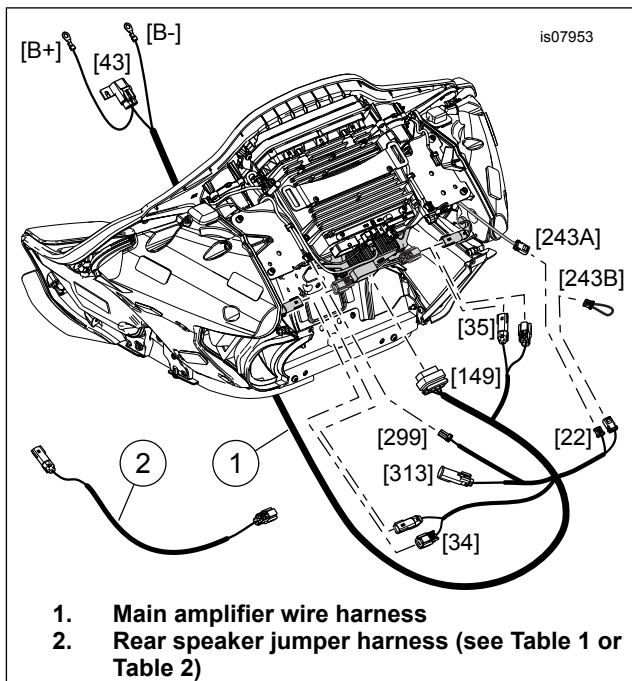

Figure 4. Harness Connections

6. Route the battery wires through the wire trough and to the correct battery terminals.
7. Remove the positive and negative battery terminals.
 - a. Place the ring terminal labeled "B+" on the positive battery terminal. Install the bolt.
 - b. Place the terminal labeled "B-" on the negative battery post. Install the bolt.
 - c. Tighten the bolts to 6.8–7.9 N·m (60–70 in-lbs).
 - d. Position the in-line fuse holder in a location that can be accessed with minimal disassembly. DO NOT place the fuse holder inside the wire trough.
8. See Figure 5. Install the wire trough cover. Cap any unused pin-side connectors with a four-way pin weather plug (Part No. 72632-10). Use the weather plug that comes with connector [313] on harness 692000478 or from the original equipment (OE) fairing harness connector [162].
9. See the service manual. Install the headlamp assembly onto the pins.

▲ WARNING

Be sure that steering is smooth and free without interference. Interference with steering could result in loss of vehicle control and death or serious injury. (00371a)

10. Secure the wire harness with cable straps from the kit. Verify that the wiring does not interfere with steering or suspension travel.

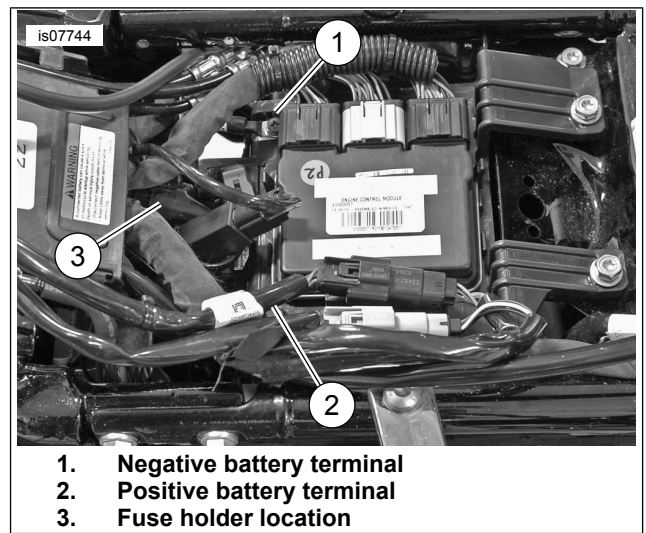

Figure 5. Battery Connection

Table 1. Connector [313] of Amplifier Harness

Model	Speaker Quantity			
	2	4	6	8
FLTRX	N/A	A	B	B

A: Connect to 69200489 jumper (for covers or rear pods) or fairing lower harness 69200612.
B: Connect to fairing lower harness 69200612.
N/A: Two speaker system does not use connector [313].

Table 2. Connector [162] of Vehicle Fairing Harness and Amplifier

Model	Speaker Quantity			
	2	4	6	8
FLTRX	N/A	D	E	E

D: Do not connect. Leave original weather cap in place.
E: Connect to 69200489 jumper. Other end of jumper to speaker expansion harness 69200490 [296].
N/A: Two speaker system does not use connector [162].

Audio System Configuration Reflash for Amplifier Installation

NOTE

DO NOT perform the system reflash using Bluetooth connection. USB connection is much faster.

1. Turn on the Digital Tech II PC. The Digital Tech II main screen is displayed.
2. Connect the TechLink II device to the DT II PC **using the USB port connector**.
3. Connect the remaining TechLink II cable to the six-way Deutsch Data Link Connector (DLC) [91] under the left side cover.
4. **Without keyless ignition:** Turn ignition switch to ACC. **With keyless ignition:** With security fob present, press and hold left side trip switch to power up accessory circuit.
5. Use the "AUTO DETECT" icon to identify the vehicle on the "VEHICLE INFORMATION" screen. The "SYSTEM INFORMATION" screen appears.
 - a. Verify that the vehicle is identified correctly on the PC screen.
 - b. Select the "checkmark" icon.
 - c. Select the "reflash" (lightning bolt) icon.
 - d. Select "RADIO".

- Verify the "REGION" is correct. Select the "SPEAKER" tab. Select the correct speaker configuration.

NOTE

Record the information on the right side of the screen before continuing to the next screen.

- Select the "OPTIONS" tab. **IMPORTANT: Select ALL the correct option boxes for the intended configuration.**
- Select "AUDIO INPUTS". Verify that all settings are correct.
- Select the "checkmark" icon to begin radio configuration. Follow the screen prompts to complete radio configuration. Return to the Digital Tech II main screen.
- Select the "refresh" (lightning bolt) icon.
- Continue through the screens that follow.
 - Select the "AMP 1" check box. Select the "checkmark" icon.
 - Select the correct "AMP EQ" from the list. Select the "checkmark" icon. Follow the on-screen instructions.
 - Check the "ARE YOU SURE?" box.

- Verify that the module part number shows the correct EQ calibration for this configuration.

NOTE

The reflash procedure takes anywhere from 2 to 20 minutes.

- Reflash of amplifier 1 begins. A progress bar appears on-screen to indicate operation status. Follow any screen prompts until completion.
- When the Amp 1 reflash is complete, return to the Digital Tech II main screen. Repeat the reflash steps for "AMP 2", "AMP 3", "AMP 4" as needed.
- Return to the Digital Tech II main screen. Select the "toolbox" icon from the top row. Select the "SYSTEM INFORMATION" icon from the lower left column. Verify that the radio and amplifiers are configured correctly.
- Check sound system for proper operation.

Completion

- See the service manual. Install the air duct, outer fairing, tank and seat.
- Use Digital Technician II to clear any codes that were set during the installation.

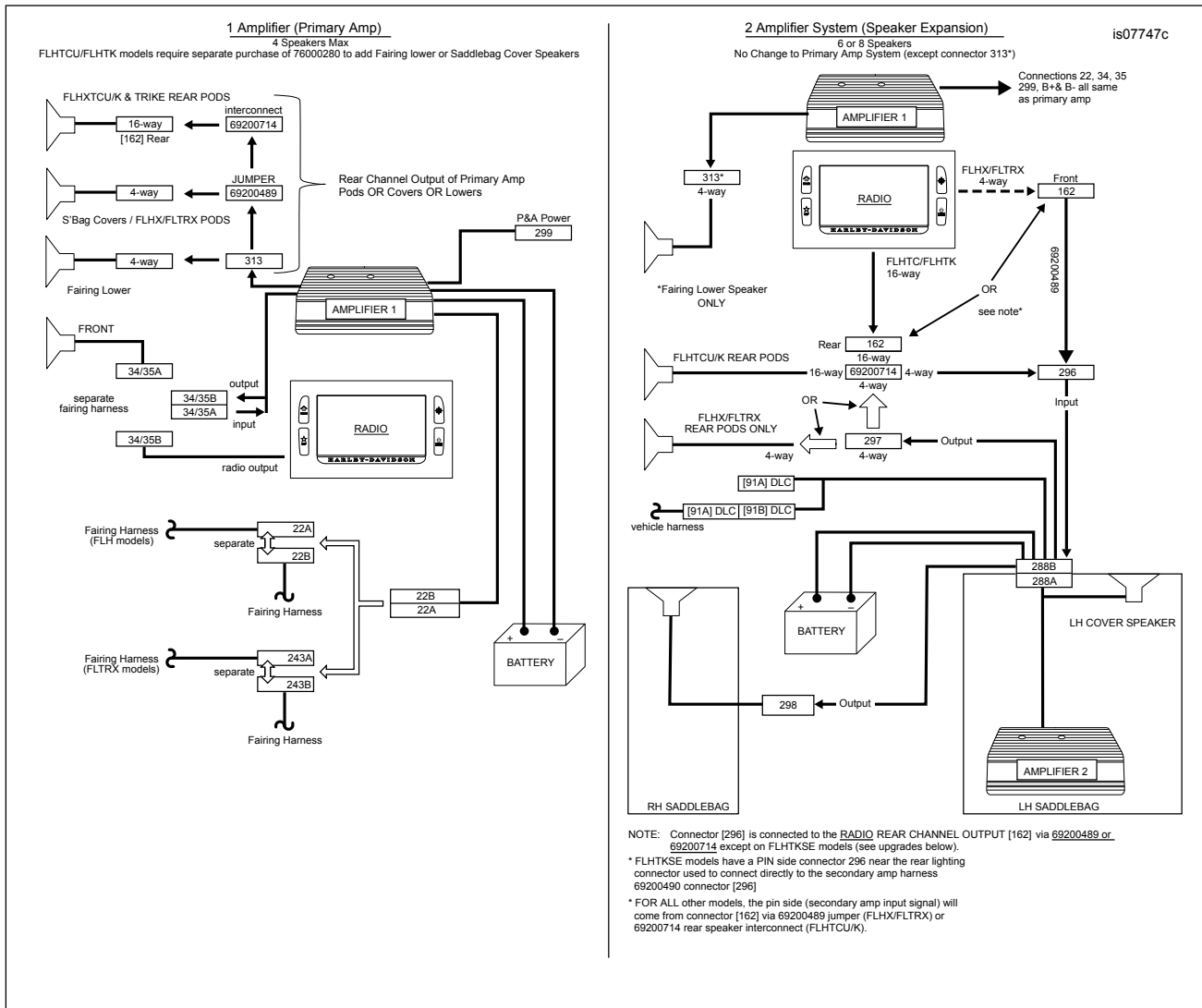

Figure 6. Amplifier Configuration

Table 3. Upgrades

UPGRADES	
FLHX/FLTRX models with 4 speaker system: upgrading to Primary Amp	
Loweres	Disconnect Lower harness (69200612) from vehicle harness radio output [162]. Reconnect to [313] of the fairing amplifier.
Pods/Covers	<ul style="list-style-type: none"> Disconnect Jumper 69200489 from vehicle harness radio output [162]. Reconnect to [313] of the fairing amplifier Replace weather cap from [313] in [162].

SERVICE PARTS

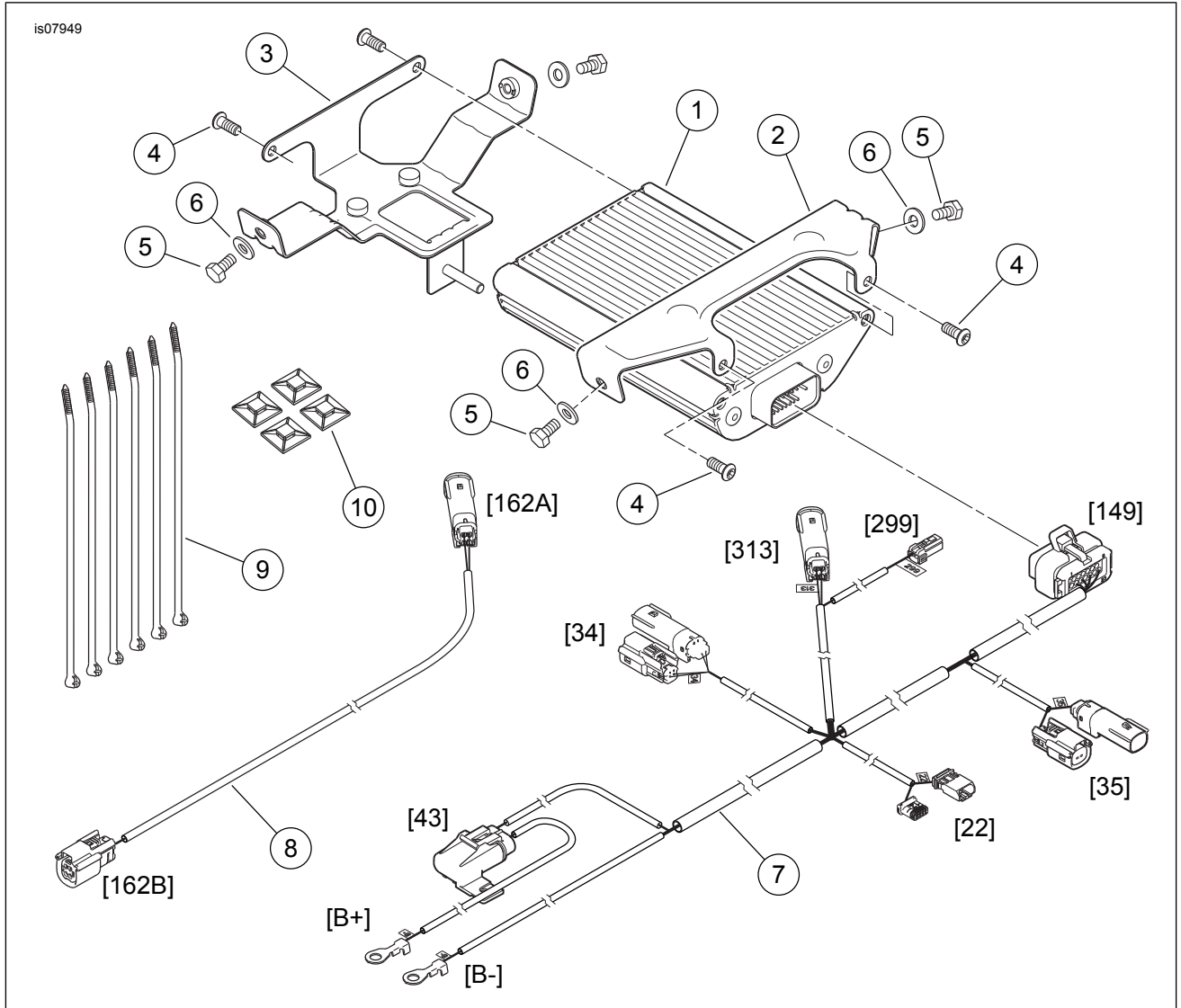

Figure 7. Service Parts, Boom! Audio Amplifier Kit

Table 4. Service Parts

Item	Description (Quantity)	Part Number
1	Audio amplifier	76000277
2	Amplifier mounting bracket, front	76000556
3	Amplifier mounting bracket, rear	76000558
4	Screw, hex socket button head, 1/4-20 x 16 mm (5/8 in) long (4)	926
5	Screw, hex head, 1/4-20 x 13 mm (1/2 in) long (4)	3728
6	Plain washer, 6.4 mm (1/4 in) I.D. (4)	6703
7	Wire harness, main amplifier	69200487
8	Wire harness, rear speaker jumper	69200489
9	Cable strap (6)	10006
10	Wire retainer, adhesive back (4)	69200342