



# INSTRUCTIONS

-J02633

REV. 2011-05-11

## CHROME HANDLEBAR SWITCH CAP KITS

### GENERAL

#### Kit Number

71802-03, 71803-03, 71804-03, 71808-03, 71816-09

#### Models

These kits contain complete sets of chrome switch caps for the left and right handlebar switches. These caps are direct replacements for the standard equipment black switch caps.

Table 1. Kits and Fitments

Kits	Fitments
71802-03	1996-Later FLHTCUI (Ultra Classic Electra Glide)
	1998-Later FLTR (Road Glide)
71803-03	1996-Later FLHT (Electra Glide Standard)
	1996-Later FLHTC (Electra Glide Classic)
71804-03	1996-Later XL
	1996-Later Dyna Glide
	1996-Later Softail
	1996-Later FLHR (Road King)
	1998 to 2001 FLHRCI (Road King Classic)
	2002-Later VRSC (V-Rod)
71808-03	2002-Later FLHRCI (Road King Classic)
71816-09	1996-Later FLHT/FLHTC and 2006-Later FLHX equipped with Cruise Control*

\* Original equipment (OE) or accessory cruise control.

#### Additional Parts Required

Ask your Harley-Davidson Dealer about Chrome Switch Housing kits and Chrome Hand Lever Bracket kits, and the selection of Handlebar Grips that are also available for these models. These items can be easily installed at the same time as this kit.

### WARNING

The rider's safety depends upon the correct installation of this kit. Use the appropriate service manual procedures. If the procedure is not within your capabilities or you do not have the correct tools, have a Harley-Davidson dealer perform the installation. Improper installation of this kit could result in death or serious injury. (00333a)

#### NOTE

This instruction sheet references service manual information. A service manual for your model motorcycle is required for this installation and is available from a Harley-Davidson dealer.

#### Kit Contents

See Figure 5 and Table 2.

### REMOVAL

1. Open or remove seat according to the instructions in the service manual.

### WARNING

To prevent accidental vehicle start-up, which could cause death or serious injury, disconnect battery cables (negative (-) cable first) before proceeding. (00307a)

### WARNING

Disconnect negative (-) battery cable first. If positive (+) cable should contact ground with negative (-) cable connected, the resulting sparks can cause a battery explosion, which could result in death or serious injury. (00049a)

### WARNING

To prevent accidental vehicle start-up, which could cause death or serious injury, remove main fuse before proceeding. (00251b)

2. Disconnect battery cables, negative (-) cable first or remove the main fuse.
3. Remove left and right side switch housing assemblies. Refer to the service manual.

#### NOTE

It is not necessary to disconnect the switch wiring to replace the switch caps.

4. Remove individual switches from switch housing. Refer to the service manual.

### INSTALLATION

#### Upper Housing Switches

1. For horn and start switch caps, release torsion spring leg from hole in switch cap tab. Take note of the spring orientation. The other leg of the spring can remain in the switch bracket hole.
2. See Figure 1 and Figure 5. Carefully pry stock black switch cap up off the splined actuator shaft (2) on left side of switch.

3. Pry the switch cap up and away from pivot pin (3) on right side of switch and remove cap.

**NOTE**

Use the clear protective cover film to protect the chrome surface of the switch caps during installation. Remove the film after the installation is complete.

4. See Figure 5. Select proper chrome replacement switch cap from kit.
5. See Figure 1. Place cap onto switch, angling the hole on right side over pivot pin (4) on switch.
6. Carefully press switch cap down onto splined actuator shaft (5), rocking and moving the cap until shaft snaps into place in splined hole.
7. For horn and start switch caps, insert torsion spring leg into hole in switch cap tab.
8. Toggle switch back and forth, checking for proper operation.

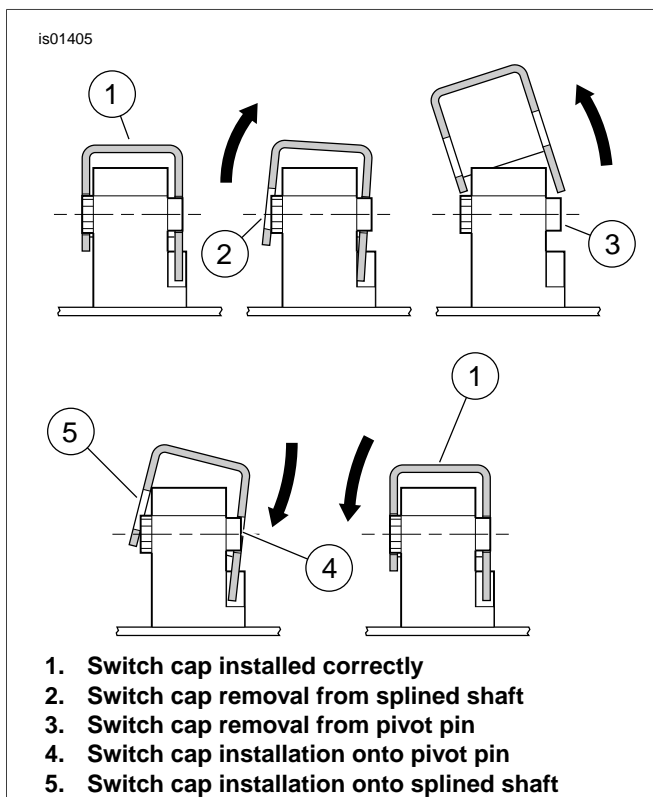

**Figure 1. Switch Cap Removal and Replacement**

**Turn Signal Switches**

1. See Figure 1 and Figure 5. Carefully pry stock black switch cap up off the splined actuator shaft (2) on switch.
2. Pry the switch cap up and away from pivot pin (3) on switch, and remove cap.
3. Select proper chrome replacement switch cap from kit.
4. See Figure 1. Place cap onto switch, angling the hole on top over pivot pin (4) on switch.
5. Carefully press switch cap onto splined actuator shaft (5), rocking and moving the cap until shaft snaps into place in splined hole.

6. Toggle switch back and forth, checking for proper operation.

**Switch Cap Replacement**

**NOTES**

The switch cap removal tool is tapered on both ends to assist in the removal of the switch caps. As the tool is pushed under the switch cap, the tapered ends will slowly push the switch cap off of the switch pin. Do not use the switch cap removal tool as a pry bar. This will damage the switch cap and switch housing.

The cruise control switch cap must be removed first before attempting to remove the mode select switch cap.

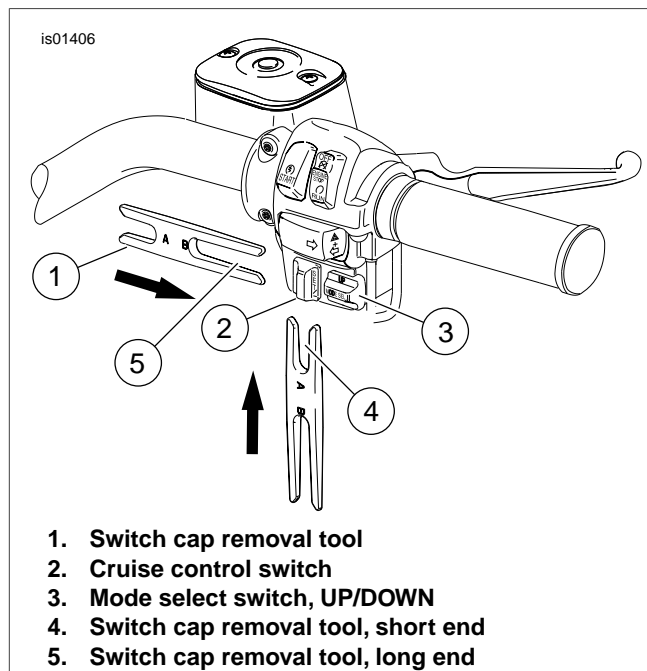

**Figure 2. Cruise Control and Mode Select Switch Caps**

1. See Figure 2. Use short end (4) of tool to remove cruise control switch cap (2). Push upwards under switch cap. The tool taper will slowly push the switch cap off switch pin.
2. See Figure 3. Use long end (Figure 2, Item 5) of tool (1) and push tool straight and under mode switch cap until it is disengaged from switch pin (2) to remove mode select switch cap (3).
3. Pull stock black switch cap from switch shaft. If there is a metal clip in the old switch cap, insert copper clip from kit into new chrome cap.
4. See Figure 5. Select proper chrome replacement switch cap from kit, then slide the cap onto the shaft.

**NOTE**

The cap will fit snugly to prevent the cap from loosening during regular operation.

5. Toggle the switch back and forth, checking for proper operation.

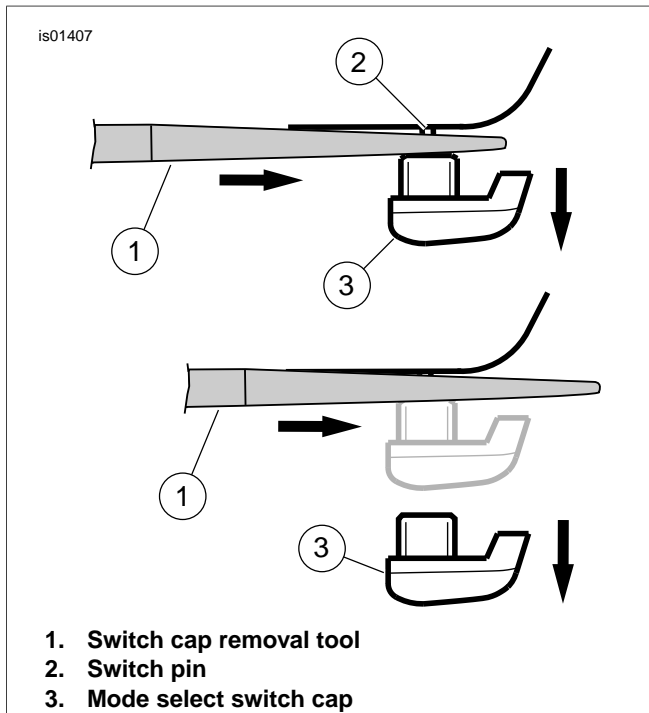

Figure 3. Mode Select Switch Cap

**NOTES**

The switch cap removal tool is tapered on both ends to assist in the removal of the switch caps. As you push the tool under the switch cap, the tapered ends will slowly push the switch cap off of the switch pin.

Do not use the removal tool as a pry bar. This will damage the switch cap and switch housing.

**For FLHTCU and FLTR Models:** The SQ-/PTT/SQ+ switch cap must be removed before attempting to remove the audio control switch cap.

6. See Figure 4. Use short end (4) of tool (1) to remove the SQ-/PTT/SQ+ switch cap (2). Push upwards under switch cap. The tool taper will slowly push switch cap off switch pin.
7. Use long end (5) of tool (1) to remove the audio control switch cap (3).

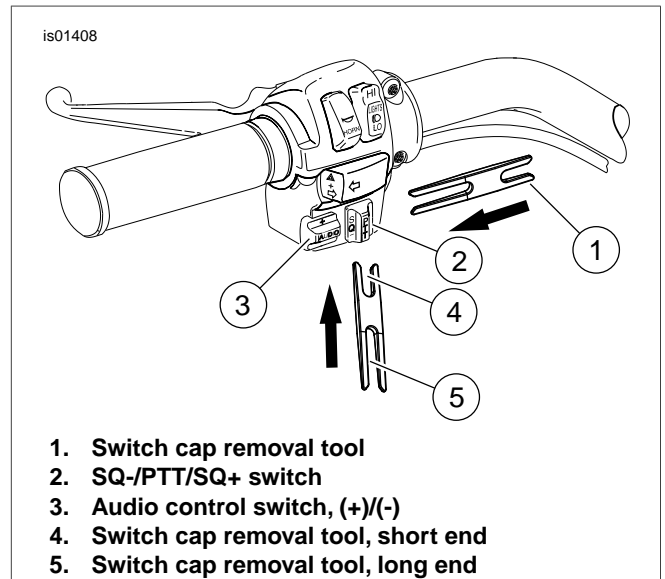

Figure 4. SQ-/PTT/SQ+ and Audio Control Switch Caps

**Assemble Switches**

1. Assemble individual switches back into switch housings. Use care when installing switches to avoid damage. Refer to the service manual.
2. Assemble left and right side switch housing assemblies. Refer to the service manual. Remove and discard clear protective installation covers.

**⚠ WARNING**

Connect positive (+) battery cable first. If positive (+) cable should contact ground with negative (-) cable connected, the resulting sparks can cause a battery explosion, which could result in death or serious injury. (00068a)

3. Connect battery cables, positive (+) cable first or install the main fuse.

**⚠ WARNING**

After installing seat, pull upward on seat to be sure it is locked in position. While riding, a loose seat can shift causing loss of control, which could result in death or serious injury. (00070b)

4. Install seat according to the instructions in the service manual.
5. Test all the handlebar switches for proper operation.

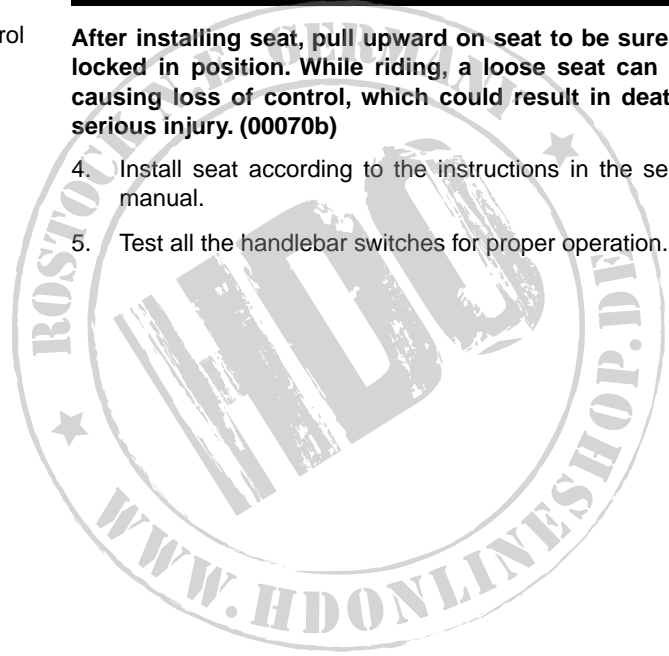

# SERVICE PARTS

is01409a

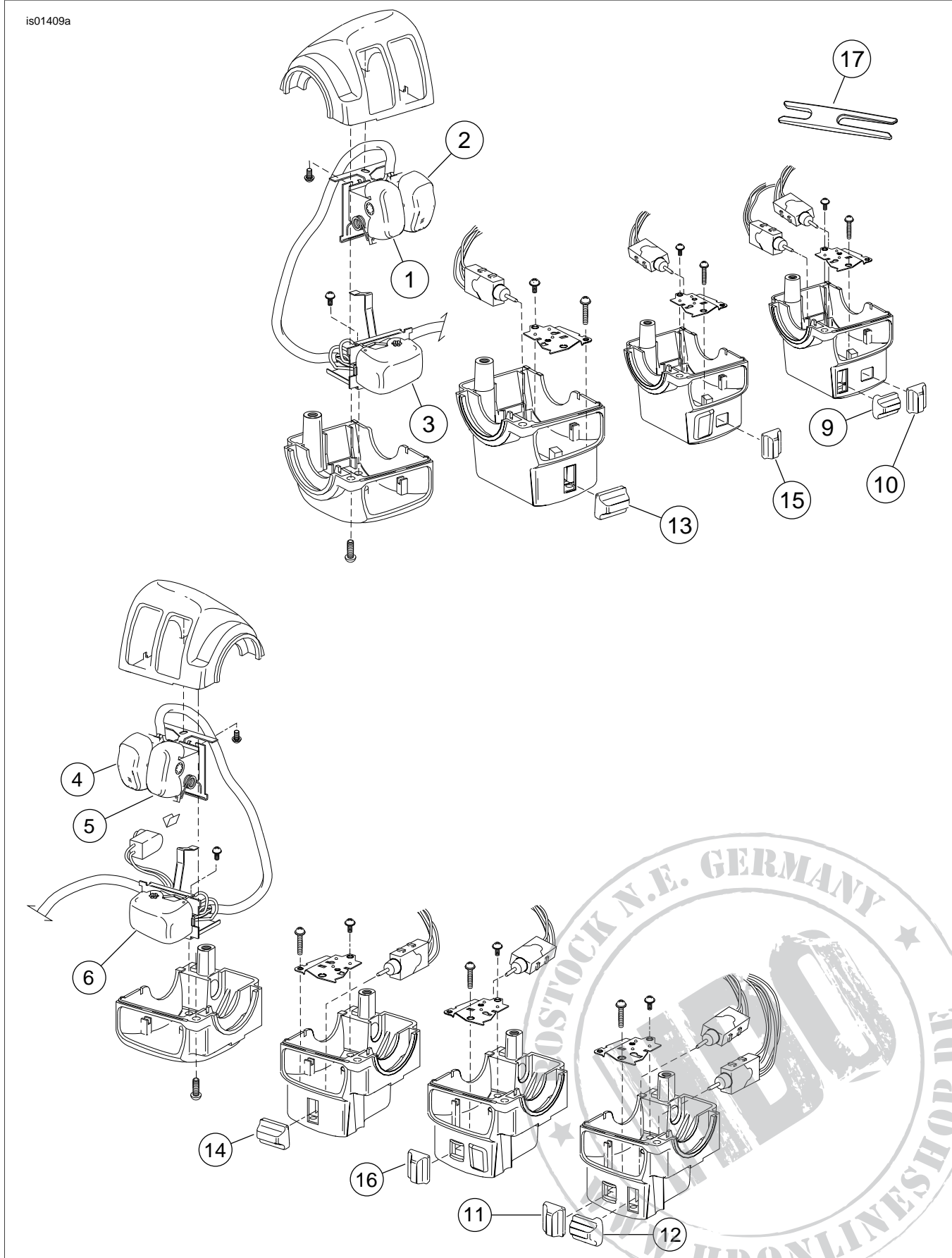

Figure 5. Service Parts: chrome Handlebar Switch Caps

**Table 2. Service Parts: Chrome Handlebar Switch Caps**

Kit	Item	Description (Quantity)	Part Number
<b>Common Items for All Kits:</b>			
	1	Switch cap, HORN (chrome)	Not Sold Separately
	2	Switch cap, LIGHTS HI/LO (chrome)	Not Sold Separately
	3	Switch cap, left turn arrow (chrome)	Not Sold Separately
	4	Switch cap, START (chrome)	Not Sold Separately
	5	Switch cap, OFF/ENGINE STOP/RUN (chrome)	Not Sold Separately
	6	Switch cap, right turn arrow (chrome)	Not Sold Separately
<b>Kit 71802-03 - Additional Contents:</b>			
	9	Switch cap, AUDIO+/- (chrome) includes copper clip	71727-03
	10	Switch cap, PTT/SQ-/SQ+ (chrome) includes copper clip	71730-03
	11	Switch cap, RES/SET (chrome) includes copper clip	71729-03
	12	Switch cap, MODE SEL UP/DN (chrome) includes copper clip	71728-03
	17	Switch cap removal tool	Not Sold Separately
<b>Kit 71803-03 - Additional Contents:</b>			
	13	Switch cap, AUDIO +/- (chrome) includes copper clip	71732-03
	14	Switch cap, MODE SEL UP/DN (chrome) includes copper clip	71733-03
	17	Switch cap removal tool	Not Sold Separately
<b>Kit 71804-03 - No additional items in kit.</b>			
<b>Kit 71808-03 - Additional Contents:</b>			
	15	Switch cap, RES/SET (chrome) includes copper clip	71729-03
	16	Switch cap, CRUISE OFF/ON (chrome) includes copper clip	71731-03
	17	Switch cap removal tool	Not Sold Separately
<b>Kit 71816-09 - Additional Contents:</b>			
	11	Switch cap, RES/SET (chrome) includes copper clip	71729-03
	12	Switch cap, MODE SEL UP/DN (chrome) includes copper clip	71728-03
	13	Switch cap, AUDIO +/- (chrome) includes copper clip	71732-03
	17	Switch cap removal tool	Not Sold Separately

