



# INSTRUCTIONS

-J04112

REV. 2007-02-19

## CHROME ON/OFF SWITCH CAP KIT

### GENERAL

#### Kit Number

71656-07

#### Models

This kit is designed for use with all models using Auxiliary On/Off Switch Kit 71718-02. The chrome items in this kit are direct replacements for the black switch cap on **that** switch, and the black switch hole plugs supplied with Auxiliary Accessory Housing kits.

#### Additional Parts Required

Please see the P&A Retail Catalog or the Parts and Accessories section of [www.harley-davidson.com](http://www.harley-davidson.com) (English only) for Chrome Auxiliary Accessory Housing kits and Chrome Hand Lever Bracket kits that are also available for your motorcycle. These items can be easily installed at the same time as this kit.

### WARNING

The rider's safety depends upon the correct installation of this kit. Use the appropriate service manual procedures. If the procedure is not within your capabilities or you do not have the correct tools, have a Harley-Davidson dealer perform the installation. Improper installation of this kit could result in death or serious injury. (00333a)

#### NOTE

This instruction sheet references Service Manual information. A Service Manual for your model motorcycle is required for this installation and is available from a Harley-Davidson dealer.

#### Kit Contents

See Figure 5 and Table 1.

There are no service parts available for this kit.

### INSTALLATION

#### Models WITH maxi-fuse:

### WARNING

To prevent accidental vehicle start-up, which could cause death or serious injury, remove maxi-fuse before proceeding. (00251a)

1. Refer to the Service Manual and follow the instructions given to remove the maxi-fuse.

#### Models WITHOUT maxi-fuse:

### WARNING

To prevent accidental vehicle start-up, which could cause death or serious injury, disconnect negative (-) battery cable before proceeding. (00048a)

1. Refer to the Service Manual and follow the instructions given to remove the seat and disconnect the negative (black) battery cable from the negative (-) battery terminal. Retain all seat mounting hardware.

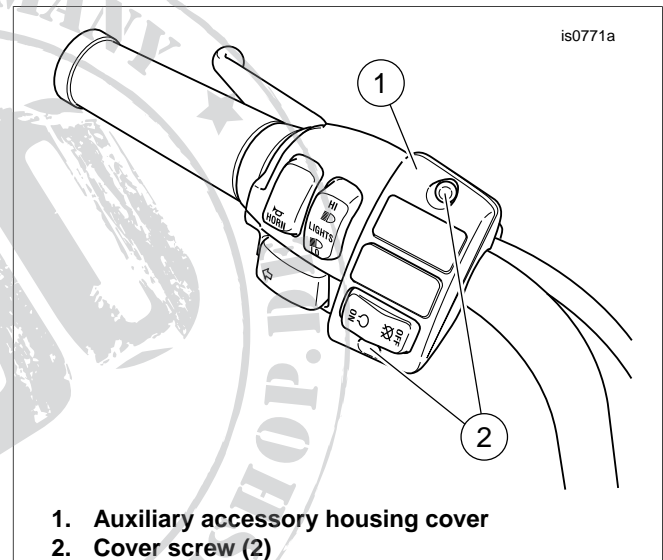

1. Auxiliary accessory housing cover
2. Cover screw (2)

Figure 1. Auxiliary Accessory Housing

#### 2. ALL models:

If the Auxiliary Accessory Housing Kit and the Rocker Switch(es) ARE NOT already installed on the motorcycle handlebar:

- a. Proceed to Step 3 of these instructions. Install a chrome switch cap onto each switch **before** installing the Auxiliary Accessory Housing Kit onto the vehicle.

If the Auxiliary Accessory Housing IS already installed on the motorcycle handlebar:

- a. See Figure 1. Using a T-25 TORX® driver, remove the two screws (2) retaining the Auxiliary Accessory Housing cover (1), and remove the cover.
- b. See Figure 2. Remove the switch mounting bracket, along with any attached switch(es) and accessories, from the switch housing.

Note: it is not necessary to remove the switch from the mounting bracket, or to disconnect the switch wiring to replace the switch caps.

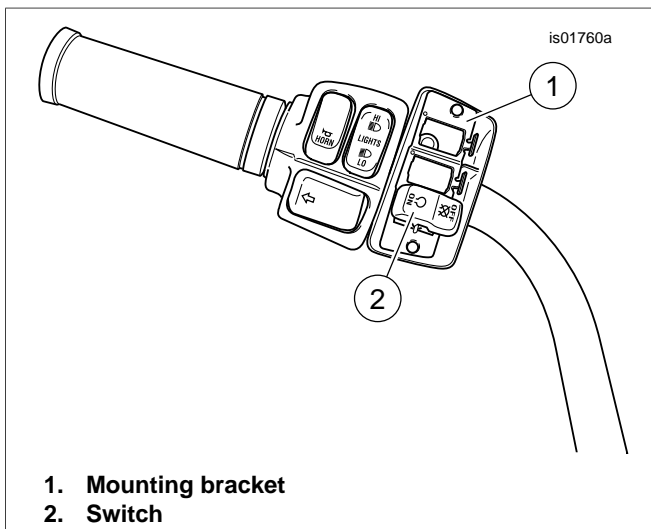

1. Mounting bracket
2. Switch

**Figure 2. Auxiliary Accessory Mounting Bracket**

3. **ALL applications:** See Figure 3. View the switch with the word "OFF" on the right. Carefully pry the black switch cap up and off the splined actuator shaft (2) on the upper side of the switch.
4. Pry the switch cap up and away from the pivot pin (3) on the lower side of the switch, and remove the cap.
5. See Figure 5. Select the chrome replacement switch cap from the kit.

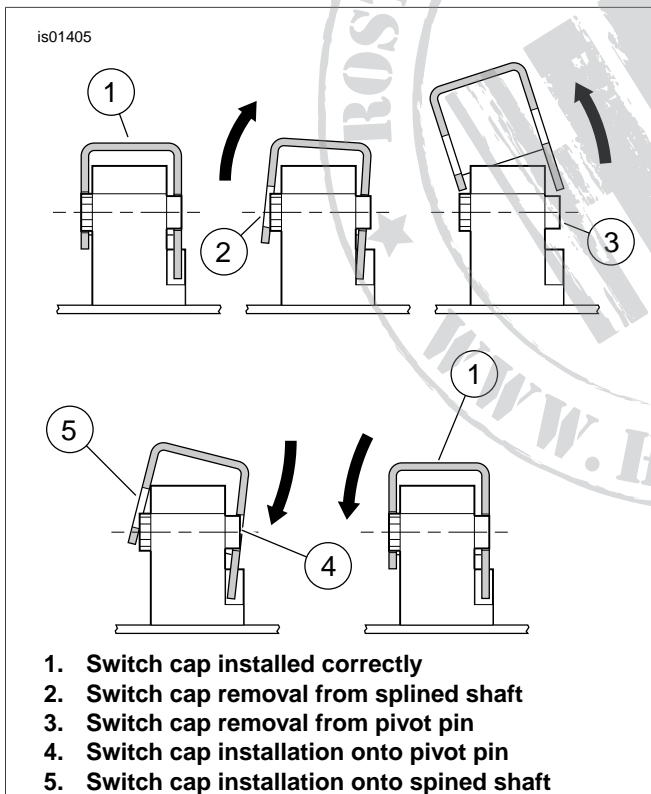

1. Switch cap installed correctly
2. Switch cap removal from splined shaft
3. Switch cap removal from pivot pin
4. Switch cap installation onto pivot pin
5. Switch cap installation onto splined shaft

**Figure 3. Switch Cap Removal and Replacement**

**NOTE**

Use the clear protective cover film to protect the chrome surface of the switch cap during installation. Remove the film after the installation is complete.

6. See Figure 3. Place the chrome cap onto the switch, angling the hole on the lower side over the pivot pin (4) on the switch.
7. Carefully press the chrome switch cap down onto the splined actuator shaft (5), rocking and moving the cap until the shaft snaps into place in the splined hole.
8. Toggle the switch "ON" and "OFF", checking for proper operation.

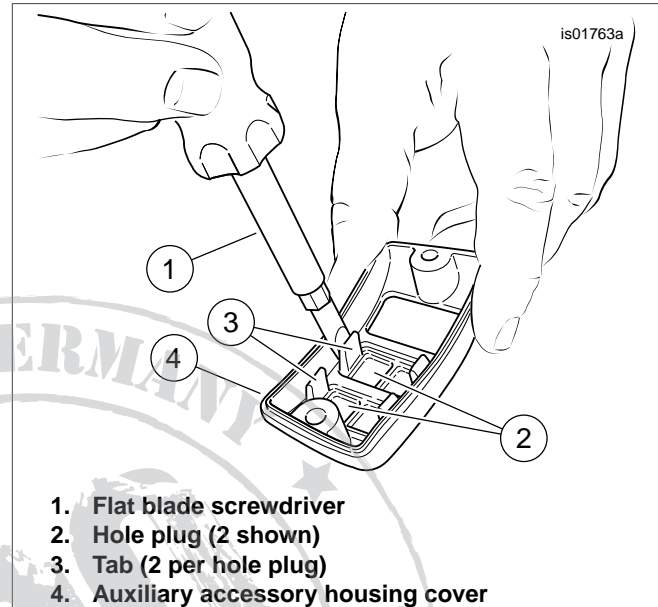

1. Flat blade screwdriver
2. Hole plug (2 shown)
3. Tab (2 per hole plug)
4. Auxiliary accessory housing cover

**Figure 4. Remove and Install Hole Plugs**

9. **If the Auxiliary Accessory Housing WAS already installed on the motorcycle handlebar:**
  - a. Install the switch bracket with the attached switch(es) and accessories into the lower housing.
  - b. If switches or accessories are not installed in one or more locations of the housing, obtain a chrome hole plug from the kit for each opening in the cover.  
See Figure 4. Using a flat-bladed screwdriver (1), carefully compress the tab (3) and remove any black hole plugs (2) from the housing cover (4). If relocating the hole plug, snap the **new** chrome plug in the desired location.
  - c. See Figure 1. Using a T-25 TORX driver, install the housing cover (1) using the two button-head screws (2) removed earlier. Tighten the screws to 35-45 **in-lbs** (4-5 Nm).

**If the Auxiliary Accessory Housing Kit and the Rocker Switch(es) WERE NOT already installed on the motorcycle handlebar:**

- a. Install the lower housing, along with the desired switches or accessories to the vehicle handlebar per the instructions in **those** kits.
- b. If switches or accessories are not installed in one or more locations of the housing, obtain a chrome hole plug from the kit for each opening in the cover.

See Figure 4. Using a flat-bladed screwdriver (1), carefully compress the tab (3) and remove any black hole plugs (2) from the housing cover (4). Snap the **new** chrome plug in the desired location.

- c. See Figure 1. Using a T-25 TORX driver, install the housing cover (1) using the two button-head screws (2) removed earlier. Tighten the screws to 35-45 **in-lbs** (4-5 Nm).

### Final Assembly

1. Verify that the Ignition/Light Key Switch is turned to the OFF position.
2. **Models WITH maxi-fuse:** Refer to the Service Manual and follow the instructions given to re-install the maxi-fuse.  
**Models WITHOUT maxi-fuse:** Apply a light coat of petroleum jelly or corrosion retardant material to the negative battery terminal. Refer to the Service Manual and follow the instructions given to re-attach the negative battery cable.
3. If removed, install the seat according to the instructions in the Service Manual.

### **⚠ WARNING**

**After installing seat, pull upward on seat to be sure it is locked in position. While riding, a loose seat can shift causing loss of control, which could result in death or serious injury. (00070b)**

4. Test the auxiliary handlebar switches and accessories for proper operation.

## SERVICE PARTS

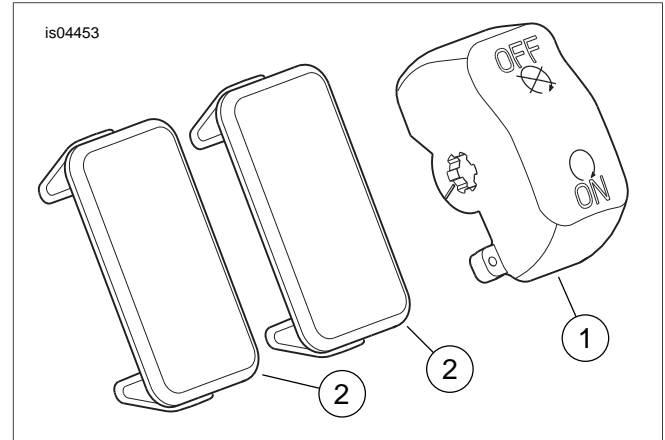

Figure 5. Service Parts, ON/OFF Switch Cap Kit

Table 1. Service Parts

Item	Description (Quantity)	Part Number
1	Cap, ON/OFF switch (chrome)	Not sold separately
2	Plug, switch hole (chrome) (2)	Not sold separately