



# INSTRUCTIONS

-J02662

REV. 2006-04-09

## DASH PANEL EXTENSION KIT

### GENERAL

#### Kit Number

71282-04

#### Models

This kit is designed to fit 2004 and later FXDWG and 2007 FXDC model motorcycles.

#### NOTE

A Service Manual for your model motorcycle is available from a Harley-Davidson Dealer.

#### Kit Contents

See Figure 1 and Table 1.

There are no Service Parts available with this kit.

### INSTALLATION

1. Remove the seat.
2. See Figure 1. Loosen the two socket head screws on the instrument panel console. Raise the console enough to access the two pushnuts holding the upper end of the leather insert. Remove and discard the pushnuts using pliers or a blade-type screwdriver.
3. Remove and discard the phillips head screw (3) and washer (4) securing the lower portion of the leather insert to the fuel tank. Remove the leather insert and discard it.
4. Obtain the dash panel extension (1) and the dash panel extension trim (2) from kit. Place the dash panel extension on the dash panel extension trim making sure the panel is centered and fits cleanly into the lips on both sides of the trim.
5. Gently lift up on the rear of the instrument panel console and install the dash panel extension with the rubber dash panel extension trim underneath, butting the two together. Make sure the rubber dash panel extension trim is aligned with the dash panel extension. Finger tighten the two socket head screws to hold down the instrument panel temporarily in place.

#### NOTE

The console rubber trim from a stock vehicle may need to be trimmed slightly to assure proper fit.

#### NOTE

When performing the next step, note that proper alignment is achieved when space is eliminated between the instrument panel console and/or between the dash panel extension trim piece and the fuel tank. Due to variances in fuel tank and instrument panel console fitments, the foam pads are used on "as needed" basis to achieve proper alignment.

It may be necessary to experiment a few times using various combinations of pads to achieve the desired alignment. In some cases, pads may not be necessary while in others, it may be necessary to use all with one stacked above another.

6. Observe the overall fitment of the panels over the tank and determine whether the foam pads will be necessary to achieve the desired alignment.
7. If necessary, remove the dash panel extension assembly. Peel the adhesive backing and install the needed foam pads (5) to the raised areas extending from the front of the dash panel extension as shown. Re-install the panel.
8. When the proper alignment between the new kit and the fuel tank is achieved, tighten the rear mounting screw (3) with the washer (4) to the speed nut located on the tab at the rear of the fuel tank.
9. Tighten to 18-24 **in-lbs** (2.0-2.7 Nm).
10. Tighten the instrument panel console's two socket head screws to 18-24 **in-lbs** (2.0-2.7 Nm).
11. Install the seat.

#### WARNING

**After installing seat, pull upward on seat to be sure it is locked in position. While riding, a loose seat can shift causing loss of control, which could result in death or serious injury. (00070b)**

# SERVICE PARTS

See Figure 1 and Table 1.

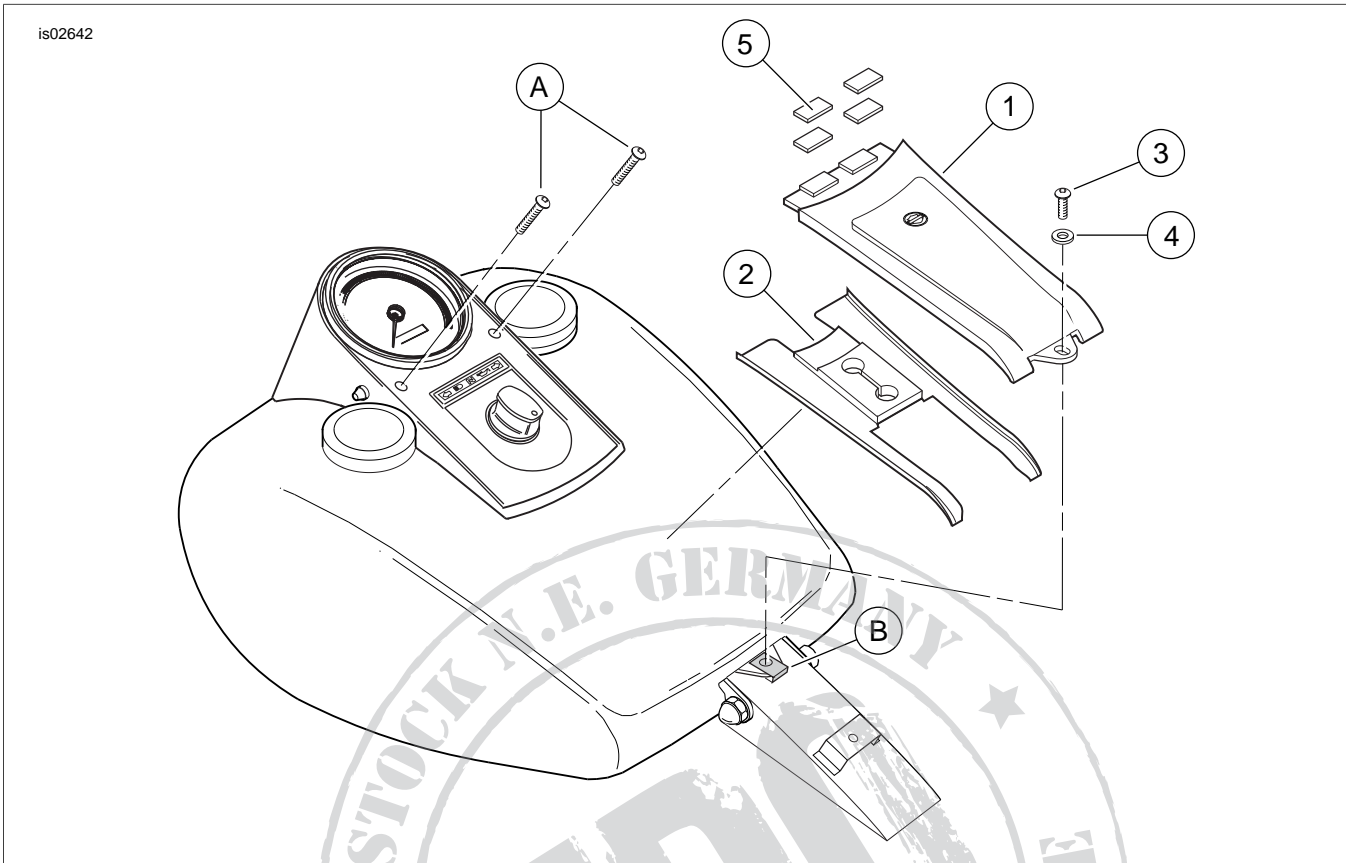

**Figure 1. Service Parts: Dash Panel Extension Kit**

**Table 1. Service Parts Table**

Item	Description (Quantity)	Part Number
1	Extension, dash panel	Not Sold Separately
2	Trim, dash panel extension	Not Sold Separately
3	Cap screw, hex head (1), 5/16-18 x 3/4 inch	94393-92T
4	Washer	Not Sold Separately
5	Pad, foam (4)	71003-01
<b>Items mentioned in text, but not included in kit:</b>		
A	Stock socket head screws (2)	
B	Speed nut	