



# INSTRUCTIONS

-J05410

REV. 2011-05-18

## TITANIUM OIL TEMP GAUGE

### GENERAL

#### Kit Number

70900176 (°F), 70900193 (°C)

#### Models

For model fitment information, see the P&A retail catalog or the Parts and Accessories section of [www.harley-davidson.com](http://www.harley-davidson.com) (English only).

#### Tools and Supplies Required

Loctite® 565 Thread Sealant (H-D Part Number 99818-97) will also be required.

These items are available from a Harley-Davidson dealer.

### WARNING

The rider's safety depends upon the correct installation of this kit. Use the appropriate service manual procedures. If the procedure is not within your capabilities or you do not have the correct tools, have a Harley-Davidson dealer perform the installation. Improper installation of this kit could result in death or serious injury. (00333a)

#### NOTE

This instruction sheet references service manual information. A service manual for this year and model motorcycle is required for this installation and is available from a Harley-Davidson dealer.

### NOTICE

It is possible to overload your vehicle's charging system by adding too many electrical accessories. If the combined electrical accessories operating at any one time consume more electrical current than the vehicle's charging system can produce, the electrical consumption can discharge the battery and cause damage to the vehicle's electrical system. See an authorized Harley-Davidson dealer for advice about the amount of current consumed by additional electrical accessories or for necessary wiring changes. (00211c)

### WARNING

When installing any electrical accessory, be certain not to exceed the maximum amperage rating of the fuse or circuit breaker protecting the affected circuit being modified. Exceeding the maximum amperage can lead to electrical failures, which could result in death or serious injury. (00310a)

This kit requires up to **300 mA** additional current from the electrical system.

#### NOTE

Do not use solvent-based chemicals or waxes directly on the plastic or rubber components as they can affect the overall performance and appearance of plastic and rubber.

#### Kit Contents

See Figure 2 and Table 1.

### INSTALLATION

#### Prepare the Motorcycle

- Follow the instructions in the service manual to:
  - Remove the oil drain plug, drain the engine oil, and remove the oil filter.
  - Inspect the oil drain plug O-ring for tears or damage, and replace if required. Wipe any oil or debris from the plug. Install the O-ring onto the plug.
  - Install the drain plug, and tighten to 14-21 ft-lbs (19-28 Nm).
  - Clean the oil filter mount of gasket material. Lube the gasket on a **new** oil filter with engine oil and install the new filter. Hand-tighten the oil filter until the gasket contacts the filter mounting surface, plus an additional 1/2-3/4 turn.

#### NOTE

Do not use the oil filter wrench to tighten the oil filter.

- Remove maxi-fuse.
- FLHT/C/U models:** Follow the service manual instructions to remove the outer fairing/windshield from the upper fairing.
- FLTR models:** Follow the service manual instructions to remove the outer fairing from the upper fairing.

#### NOTE

While the two-inch oil temperature gauge can replace any of the four factory-installed two-inch gauges or plugs, these instructions will assume the gauge is being mounted in the lower left location as viewed from the rider position.

- Models WITH air temperature gauge:** Remove the air temperature gauge.
  - Disconnect the three-way and two-way socket housings to release the interconnect harness from the air temperature gauge and lamp.
  - Remove the hex nuts from the gauge mounting studs, and remove the mounting bracket.
  - Remove the gauge from the inner fairing.

**Models WITHOUT air temperature gauge:** Remove the plug from the lower left-side gauge opening (below the fuel gauge).

## Install the Oil Temperature Gauge

1. See Figure 2. Obtain the oil temperature gauge (1) from the kit. From the rider position, rotate the gauge to align the face legend horizontal to the rider, and push the gauge into the fairing.
2. From the front of the vehicle, slide the gauge mounting bracket (B) over the threaded gauge studs to engage the tabs of the bracket into the inner fairing.
3. Install two locknuts (A) and tighten to 10-20 **in-lbs** (1.1-2.3 Nm).

## Install the Oil Temperature Sending Unit

1. See Figure 1. Remove the unused pipe plug (3) (**NOT** the engine oil drain plug, item 2) from the left front of the oil pan.

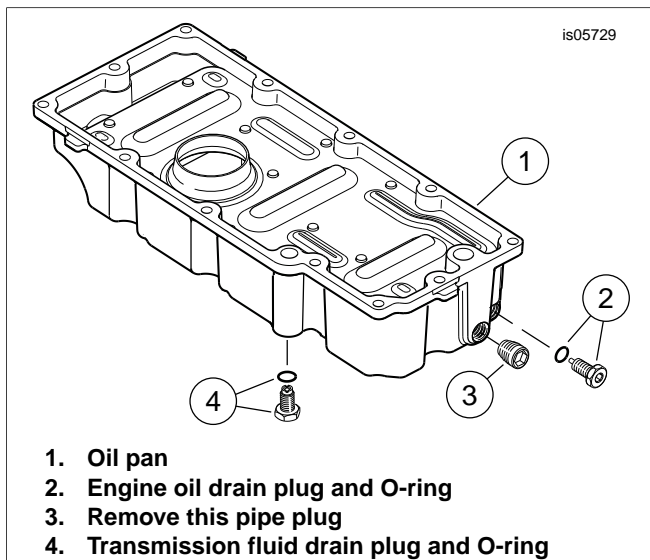

Figure 1. Oil Pan and Plugs, FL Touring Models

2. See Figure 2. Obtain the oil temperature sending unit (2) and adapter fitting (3) from the kit. Coat the clean threads of the adapter fitting with Loctite 565 Thread Sealant, and install the fitting into the pipe plug hole in the oil pan.
3. Coat the clean threads of the sending unit with Loctite 565 Thread Sealant, and install the sending unit into the adapter fitting.

## Route the Wire Harness

1. Obtain the oil temperature gauge wiring harness (4) from the kit. Plug the two-way connector on one end of the harness into the mating connector on the oil temperature sensor.

2. Route the harness:
  - a. to the right side frame tube.
  - b. Follow the rear brake line routing to the brake side foot control.
  - c. Secure the wire harness to the frame tubes with cable straps (5) from the kit.

### NOTE

**DO NOT** secure the harness to the brake line.

3. Continue the wire harness up the right-side frame tube, and through the P-clamp located near the steering head. Locate connector 107 (air temp sensor). See service manual and disconnect air temp sensor (if equipped).
4. Connect the 3-way end of the harness from the kit to the mating connector at location 107.
5. Reconnect 2-way connector (114) and 3-way connector (115) to the back of the oil temp gauge.
6. Check along the path of the oil temperature gauge wiring harness for:
  - a. Pinch points between suspension components and the harness.
  - b. Clearance from heat sources along the harness
  - c. Pinch points in the steering (turn the front forks from lock to lock).

## RETURN TO SERVICE

1. **FLHT/C/U models:** Follow the service manual instructions to install the outer fairing/windshield to the upper fairing.  
**FLTR models:** Follow the service manual instructions to install the outer fairing to the upper fairing.
2. Install the headlamp according to the procedures in the service manual.
3. Verify that the ignition/key switch is turned to the OFF position.  
Install maxi-fuse.
4. Align the headlamp according to the instructions in the service manual.
5. Add engine oil. See the service manual.
6. Test the oil temperature gauge. Turn the ignition switch to ON, but do not start the engine. The gauge should illuminate and read the ambient temperature or remain pegged at the lowest graduation.
7. Start the engine. With the engine running, the oil temperature should rise as the engine warms up to 230°F, 110°C at operating temperature.

## SERVICE PARTS

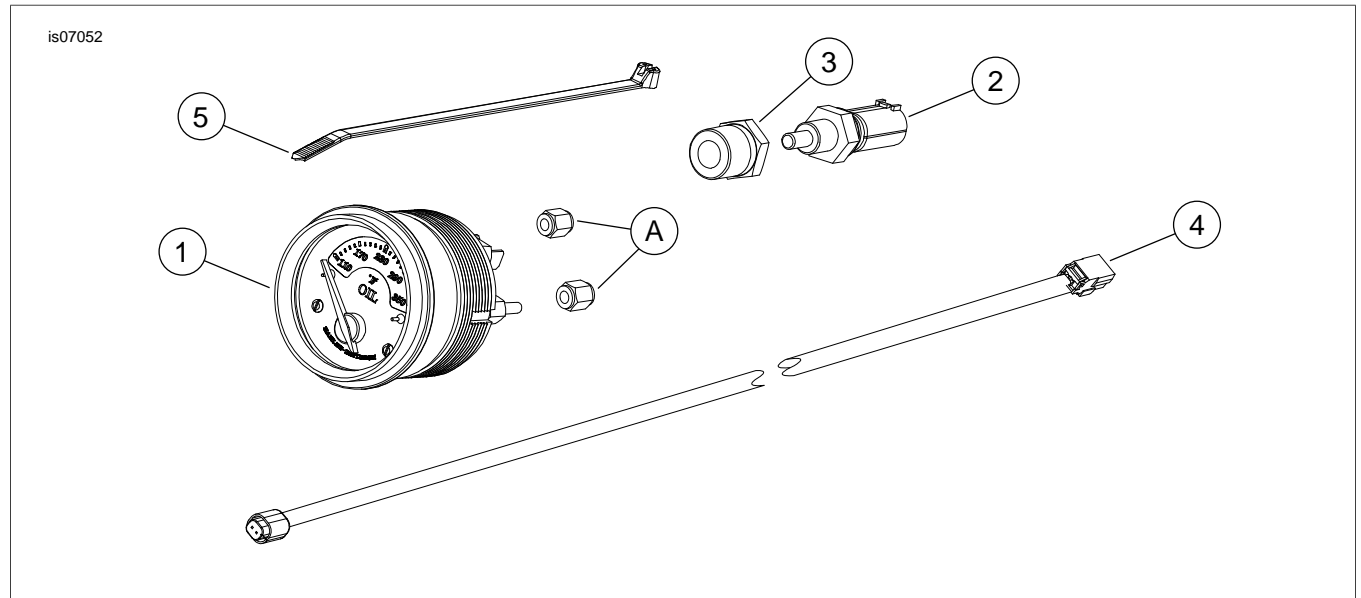

Figure 2. Service Parts: Titanium Oil Temp Gauge

Table 1. Service Parts Table

Item	Description (Quantity)	Part Number
1	Oil temperature gauge (2 gauges, F and C scales)	Not sold separately
2	Sending unit, oil temperature gauge	72357-04
3	Adapter fitting, 3/8 NPT external-1/8 NPT internal thread	Not Sold Separately
4	Wiring harness, oil temperature gauge	69200297
5	Cable strap (6)	10006
<b>Item mentioned in text, but not included in kit:</b>		
A	Hex nut, metric M4 (2) (for mounting gauge to bracket)	
B	Gauge mounting bracket (Not Shown)	

