



# INSTRUCTIONS

-J05286

REV. 2010-10-07

## DIGITAL GEAR INDICATOR

### GENERAL

#### Kit Numbers

70900038, 70900078

#### Models

For model fitment information, see the P&A Retail Catalog or the Parts and Accessories section of [www.harley-davidson.com](http://www.harley-davidson.com) (English only).

#### Additional Parts Required

**For 2007 and 2008 1200 Sportster Models:** An ECM calibration update with DTII is required for 5<sup>th</sup> gear indication to work correctly. Have the dealer install the indicator and perform the update, or after installing the indicator, take the motorcycle to the dealer as soon as possible for the update.

If an existing accessory is already using the data link connector [91], separate purchase of an adapter harness (Part No. 70264-94A) will be required for proper installation.

### **⚠ WARNING**

The rider's safety depends upon the correct installation of this kit. If the procedure is not within your capabilities or you do not have the correct tools, have a Harley-Davidson dealer perform the installation. Improper installation of this kit could result in death or serious injury. (00308a)

#### NOTE

This instruction sheet references service manual information. A service manual for your model motorcycle is required for this installation and is available from a Harley-Davidson dealer.

#### Kit Contents

See Figure 3 and Table 1.

### INSTALLATION

### **⚠ WARNING**

To prevent accidental vehicle start-up, which could cause death or serious injury, remove main fuse before proceeding. (00251b)

### **⚠ WARNING**

To prevent accidental vehicle start-up, which could cause death or serious injury, disconnect negative (-) battery cable before proceeding. (00048a)

1. See the owner's manual and remove the main fuse or disconnect the negative battery cable (-).
2. See Figure 1. Remove screws (1), washers (2) and clamp (3).

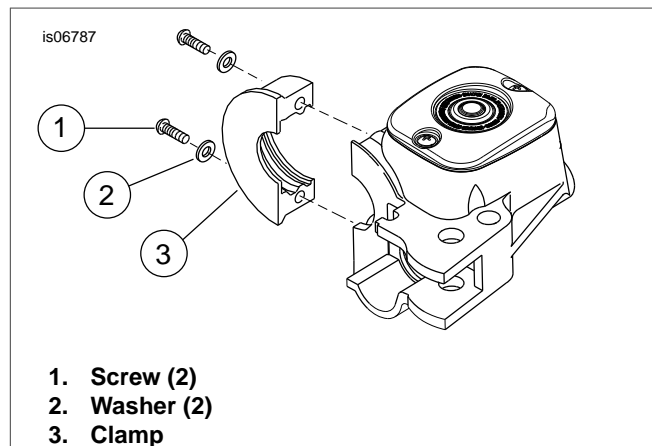

Figure 1. Remove Clamp

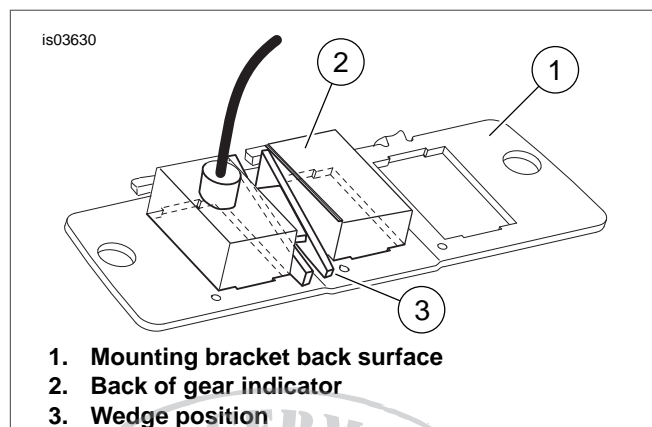

Figure 2. Mounting Bracket and Indicator Assembly Back View

3. See Figure 3. Install gear indicator lower housing (1), washers (2) and screws (3). Tighten screws to 60-80 in-lbs (8-9 Nm).
4. See Figure 2. Install the gear indicator (2) with the wires into the upper mounting bracket opening.
5. Slide the wedge (3) with the pointed ends between the two boxes on the back of the gear indicator (2) from the tab side of the bracket (1). The wedge pointed ends are different thicknesses and have to conform to the step of the housing plate surface. This will secure the gear indicator tightly to the mounting bracket surface.
6. See Figure 3. Route the wiring harness of the gear indicator through the hole in the bottom of the lower housing (1).
7. Orient the gear indicator assembly (4) over the assembly mounting holes of the lower housing.

8. Orient the upper housing over the gear indicator assembly and align with the indicator assembly mounting holes.
9. Install upper housing (5) over the lower housing and secure with two screws (6). Tighten the screws to 35-45 **in-lbs** (4-5 Nm).
10. Install the switch plug (12) in the lower opening of the upper housing.

**NOTE**

*Depending on the location of the data link connector [91], it may be necessary to remove the seat and loosen the fuel tank to properly route the wiring harness. If necessary, see the service manual for additional information.*

11. Route the digital gear indicator harness to the data link connector [91] as follows:
  - a. If the turn signal wiring is exposed, route the gear indicator harness along the handlebar following the turn signal wiring.  
If the turn signal wiring is not exposed, route the gear indicator harness along the brake line to the fork clamp and then to the main harness.
  - b. Route the gear indicator harness to the data link connector in the following locations:  
**For XL models:** Under the left side cover  
**For Dyna models:** Under the electrical caddy cover  
**For Softail models:** Under the seat  
**For Touring models:** Under the left side cover  
**For VRSC models:** Under the right, front side cover  
**For Trike models:** Under the left side cover

**NOTE**

*See the service manual for additional information on assembling the Deutsch connector, if necessary.*

12. See Figure 3. Install the three pins of the wiring harness into the 4-way socket housing (A) from the kit as follows:
  - a. Install the black (BK) wire into terminal 2.
  - b. Install the yellow/orange (Y/O) wire into terminal 3.
  - c. Install the orange (O) wire into terminal 4.
  - d. Install secondary lock (9) into the 4-way socket housing.

13. Connect the gear indicator harness to the data link connector [91].
14. Gather any excess harness and secure near the connector with a cable strap (7).
15. Secure the gear indicator harness to the handlebar and main harness with cable straps (7).
16. See the service manual and install the fuel tank, if loosened or removed.
17. See the owner's manual and install the main fuse or connect battery.

**WARNING**

**After installing seat, pull upward on seat to be sure it is locked in position. While riding, a loose seat can shift causing loss of control, which could result in death or serious injury. (00070b)**

18. See the owner's manual and install the seat, if removed.
19. **For 2007 and 2008 1200 Sportster Models:** Perform an ECM calibration update using DTII. This step requires the use of DTII and can be performed by a dealer technician. Without this update a bar (-) may appear instead of the correct readout in fifth (5) gear.

**OPERATION**

**NOTE**

*Under rare conditions the gear indicator may miss the neutral signal and continue to display a bar (-) symbol. Normal indicator function will be restored simply by shifting out of neutral. The green neutral light on the vehicle should always take precedence.*

- Upon startup and when the clutch lever is engaged, the digital gear indicator will display a bar (-). The gear indicator will also display a bar (-) in the event of a communications error.
- During operation the digital gear indicator will show the vehicle's current gear (1, N, 2, 3, 4, 5 and 6, if equipped) in the gear indicator's display when the clutch lever is disengaged.



# SERVICE PARTS

is06786

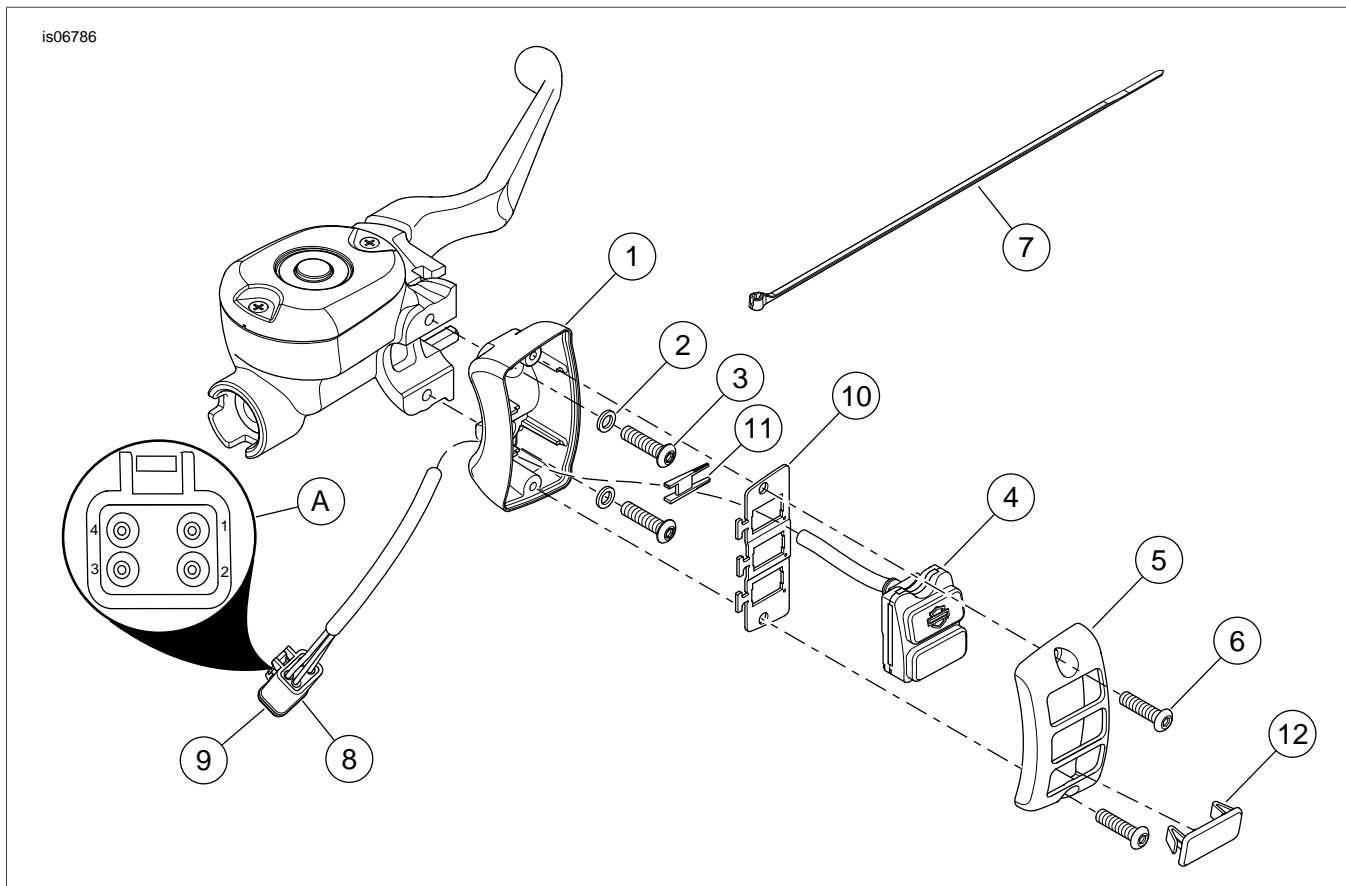

Figure 3. Service Parts: Digital Gear Indicator

Table 1. Service Parts Table

Item	Description (Quantity)	Part Number
1	Housing, lower (black)	71713-02B
	Housing, lower (chrome)	71712-02B
2	Washer (2)	6099
3	Screw (2) (All models except XL)	4015
	Screw, M6 X 1.0 X 20 mm (2) (XL models)	3832M
4	Digital gear indicator assembly	Not Sold Separately
5	Housing, upper (black)	71711-02
	Housing, upper (chrome)	71710-02
6	Screw (2) (black)	3658
	Screw, stainless (2) (chrome kit)	4292
7	Cable strap (6)	10181
8	Housing, 4-way socket	72114-94BK
9	Secondary lock, 4-way socket	72154-94
10	Bracket, switch support	69200219
11	Wedge	62981-02
12	Plug, switch	71715-02B
<b>Items mentioned in text:</b>		
A	Deutsch connector terminal numbers	