



# INSTRUCTIONS

-J03508

REV. 2006-06-09

## LED TAIL LAMP

### GENERAL

#### Kit Number

69366-07 (Red lens), 69367-07 (Clear lens).

#### Models

These kits fit:

- 2000 and later FXSTD (Softail® Deuce™)
- All 2002 and later VRSC™ models

#### Additional Parts Required

##### NOTE

*This instruction sheet references Service Manual information. A Service Manual for your model motorcycle is required for this installation, and is available from a Harley-Davidson Dealer.*

#### Kit Contents

Table 1. Kit Contents

Description (Quantity)	Part Number
Tail lamp, LED	Not sold separately
Gasket	
• For FXSTD (Deuce™)	69384-05
• For all V-Rod® models <b>except</b> VRSCR (Street Rod™)	69385-05
• For VRSCR (Street Rod™)	68071-06
Dielectric grease, 5 gram (0.176 oz.) packet	Not sold separately

### INSTALLATION

For models WITH maxi-fuse:



**To prevent accidental vehicle start-up, which could cause death or serious injury, remove maxi-fuse before proceeding. (00251a)**

1. Refer to the Service Manual and follow the instructions given to remove the maxi-fuse.

For models WITHOUT maxi-fuse:



**To prevent accidental vehicle start-up, which could cause death or serious injury, disconnect negative (-) battery cable before proceeding. (00048a)**

1. Refer to the Service Manual and follow the instructions given to remove the seat and disconnect the negative (black) battery cable from the negative (-) battery terminal. Retain all seat mounting hardware.

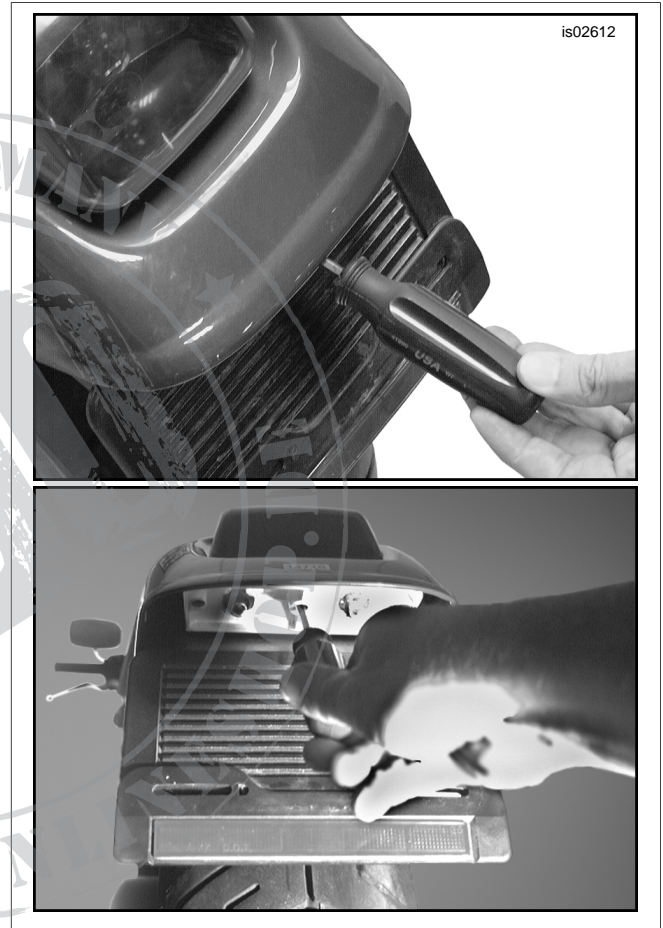

Figure 1. Removing the Tail/ Stop Lamp Assembly

2. See Figure 1. Insert a Phillips-head screwdriver into the middle hole of the license plate illuminator assembly. Push forward with the screwdriver to disengage the retaining clip while gently lifting the rear of the tail/stop lamp assembly and pulling it away from the fender.



**Figure 2. Tail/ Stop Lamp Wiring**

3. Disconnect the tail/stop lamp from the vehicle harness at the 4-place Multilock connector [93], and remove the lamp from the vehicle.

**For all FXSTD and 2002-2006 VRSC models:**

- a. See Figure 2. The connector is located inside the fender at the tail/stop lamp opening.

**For 2007 and later VRSC models:**

- a. Open the seat, and remove the passenger pillion per the instructions in the Service Manual. The connector is located under the pillion.

- b. See Figure 3.

**For models EXCEPT VRSCR:** Remove the six hex head cap screws (3) and flat washers (4) retaining the rear fender (2) and passenger grab strap (5) to the vehicle frame (1). Unclip the rear electrical caddy and Engine Management (EVMS) Module (6) from the slots (7) in the frame to gain access to the middle two screws.

**For VRSCR models:** Remove the four hex socket button head cap screws (3) and flat washers (4) retaining the rear fender (2) and passenger grab strap (5) to the vehicle frame (1).

- c. Raise the rear fender slightly to allow the rear half of the tail/stop lamp connector to fit through the gap between the fender and frame so the lamp can be removed from the vehicle.

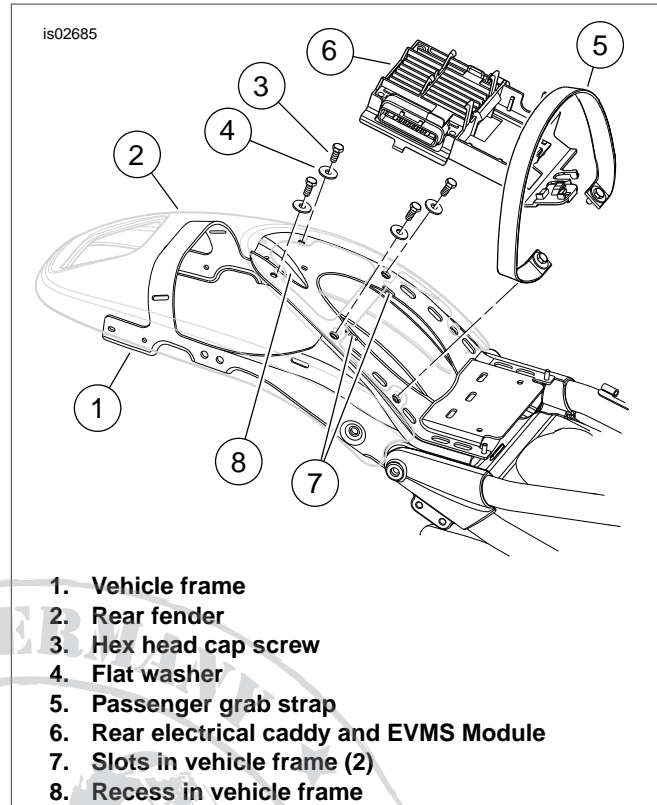

**Figure 3. Rear Fender, 2007 and Later VRSC (VRSCA Shown)**

**NOTES**

*The gasket part number is molded into the large pad (see Figure 4, item 5) found at one end of the gasket.*

*Use soapy water to ease the installation of the gasket to the LED tail/stop lamp.*

4. Refer to Table 1 to select the correct gasket for your vehicle from the kit. See Figure 4. Assemble the gasket to the **new** LED tail/stop lamp as follows:
  - a. With the part number (5) facing **away** from the lamp, insert the small tab (see inset 1, a) at the opposite end of the gasket into the open slot (b) in the lamp base as shown.
  - b. See inset 2. Carefully slip the two slots (a) in the gasket over the tabs (b) on the outer rim of the lamp base.
  - c. Work the three slots (c) in the gasket tab over the hooks (d) on the lamp base, taking care to avoid breaking the hooks.
  - d. See inset 3. Repeat steps 4b and 4c for the opposite side of the gasket.
  - e. See inset 4. Pulling the free end of the gasket, twist the three wide tabs (a) downward to allow insertion into the open slots (b) in the lamp base as shown.
  - f. Examine the installed gasket for proper fit to the LED tail/stop lamp around the entire rim.

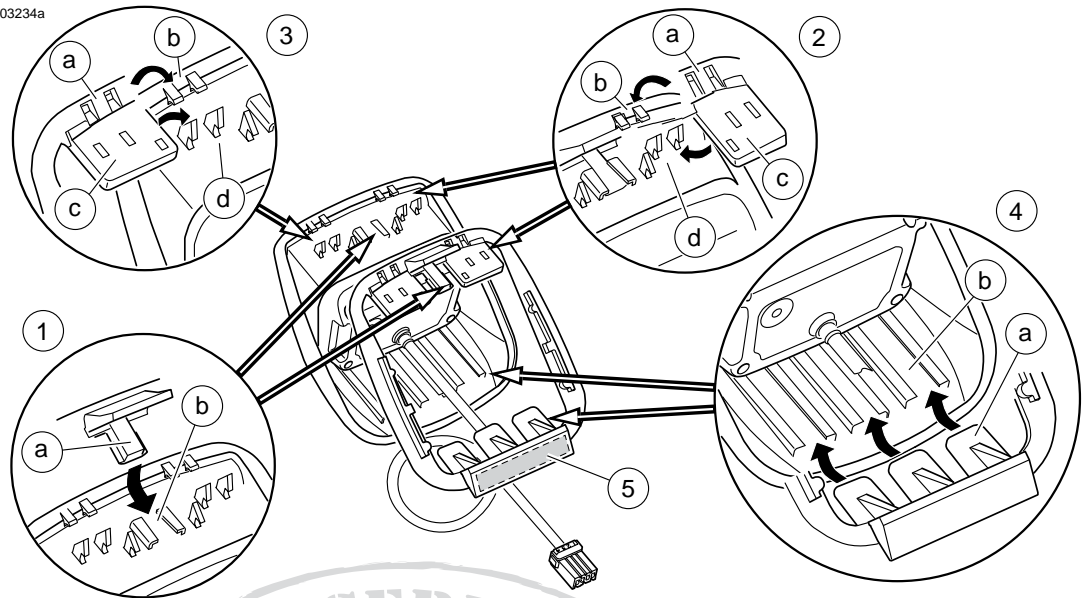

1. Insert small tab in gasket into open slot in lamp base
2. Slip two slots in gasket over tabs on lamp base outer rim. Work three slots in gasket tab over lamp base hooks.
3. Repeat for opposite side
4. Twist three tabs down and insert into open slots
5. Gasket part number molded into large pad

Figure 4. Tail/Stop Lamp Gasket Installation

**NOTE**

Fill the pin cavities of the tail/stop lamp connector housing on the vehicle harness with dielectric grease from the packet in the kit before assembling the connector halves.

5. Connect the tail/stop lamp to the vehicle harness connector [93].

**For all FXSTD and 2002-2006 VRSC models:**

- a. See Figure 2. The connector is located inside the fender at the tail/stop lamp opening. Fill the pin cavities of the connector half on the vehicle harness with dielectric grease before assembling the tail/stop lamp connector.

**For 2007 and later VRSC models:**

- a. Route the connector on the tail/stop lamp into the tail lamp opening in the fender. Raise the rear fender slightly, and fit the connector and wiring through the gap between the fender and frame.

**For models EXCEPT VRSCR:** See Figure 3. The tail lamp wires should fit into the trough (8) in the frame at the centerline of the vehicle.

**For VRSCR models:** Route the tail lamp wires through the gap to the left of the rearmost left-side fender mounting screw.

Fill the pin cavities of the tail/stop lamp connector half on the vehicle harness with dielectric grease before assembling the connector.

- b. **For ALL VRSC models:** Fasten the rear fender and passenger grab strap to the frame with the screws and flat washers removed earlier.

**For VRSCR models:** Tighten the four hex socket button head cap screws to 4.5-7.5 Nm (40-66 in-lbs).

**For models EXCEPT VRSCR:** Tighten the six hex head cap screws to 20-26 Nm (15-19 ft-lbs). Clip the rear electrical caddy and Engine Management (EVMS) Module to the frame at the two slots (7).

- c. **For ALL VRSC models:** Re-install the passenger pillion and close the seat per the instructions in the Service Manual.

**NOTE**

The tail/stop lamp will fit into the fender opening facing either direction. When installing the lamp assembly, make sure the LEDs are pointed **rearward**.

6. Route all electrical connectors and wiring harnesses to either side of the tail lamp opening in the fender, away from the LED tail/stop lamp base.
7. Install the tail/stop lamp into the fender opening as follows:
  - a. Insert the thick tab on the forward end of the tail/stop lamp gasket under the forward edge of the fender opening.
  - b. **Carefully** push the lamp assembly toward the front of the vehicle.
  - c. Align the four small retaining tabs on the rearward end of the gasket with the rearward edge of the fender opening.
  - d. Gently press down on the lamp assembly until the lamp snaps securely into place.

**NOTE**

The retaining tabs must firmly engage the edge of the fender opening for the lamp to remain locked into position. Wiggle the lamp in the opening to check for proper engagement.

## CAUTION

**Do not over-tighten bolts on battery terminals. Use recommended torque values. Over-tightening battery terminal bolts could result in damage to battery terminals. (00216a)**

8. Verify that the Ignition/Light Key Switch is in the OFF position.

**Models WITH maxi-fuse:** Refer to the Service Manual and follow the instructions given to re-install the maxi-fuse.

**Models WITHOUT maxi-fuse:** Re-connect the negative (-) battery cable per the instructions in the Service Manual. Apply a light coat of petroleum jelly or corrosion retardant material to the battery terminal.

Refer to the Service Manual, and follow the instructions given to re-install the seat.

## ⚠ WARNING

**After installing seat, pull upward on seat to be sure it is locked in position. While riding, a loose seat can shift causing loss of control, which could result in death or serious injury. (00070b)**

## ⚠ WARNING

**Be sure headlamp, tail and stop lamp and turn signals are operating properly before riding. Poor visibility of rider to other motorists can result in death or serious injury. (00478b)**

9. Turn the Ignition/Light Key Switch to ON, but do not start the motorcycle. Test for proper tail lamp and stop lamp operation.

