



INSTRUCTIONS

-J03729

REV. 2006-10-09

CUSTOM AUXILIARY LIGHTING KIT

GENERAL

Kit Number

69227-04A

Models

For model fitment information, please see the P&A Retail Catalog or the Parts and Accessories section of www.harley-davidson.com (English only).

Additional Parts Required

Turn signal assembly must be purchased separately.

Use existing sealed beams, lens/bulb assemblies, and trim rings (if applicable). Otherwise, these parts can be purchased separately from a Harley-Davidson dealer.

FLHR and FLHRS models equipped with windshield require the separate purchase of Hardware Kit 69235-04. FLHRS models can be made "windshield ready" with the additional purchase of Hardware Kit 69234-04. These kits are available from a Harley-Davidson dealer.

WARNING

The rider's safety depends upon the correct installation of this kit. Use the appropriate service manual procedures. If the procedure is not within your capabilities or you do not have the correct tools, have a Harley-Davidson dealer perform the installation. Improper installation of this kit could result in death or serious injury. (00333a)

NOTE

This instruction sheet references Service Manual information. A Service Manual for your model motorcycle is required for this installation and is available from a Harley-Davidson dealer.

Kit Contents

See Figure 9 and Table 1.

REMOVAL

WARNING

To prevent accidental vehicle start-up, which could cause death or serious injury, disconnect battery cables (negative (-) cable first) before proceeding. (00307a)

WARNING

Disconnect negative (-) battery cable first. If positive (+) cable should contact ground with negative (-) cable connected, the resulting sparks can cause a battery explosion, which could result in death or serious injury. (00049a)

1. *2003-Earlier Models:*
 - a. Remove seat according to the instructions in the Service Manual.
 - b. Disconnect battery cables, negative (-) cable first. Refer to BATTERY in Service Manual.

WARNING

To prevent accidental vehicle start-up, which could cause death or serious injury, remove maxi-fuse before proceeding. (00251a)

2. *2004-Later Models:*
 - a. Remove left side saddlebag. Refer to SADDLEBAG REMOVAL in Service Manual.
 - b. Remove left side cover and maxi-fuse. Refer to SYSTEM FUSES in Service Manual.
3. See Figure 1. Remove original equipment auxiliary lamp (1) and bracket assembly (2) if equipped. Refer to AUXILIARY LAMPS in Service Manual. Save sealed beams, lens/bulb assemblies, and trim rings for kit installation.

NOTE

On 2006 and later Touring models equipped with Delphi 2-place connectors in each auxiliary lamp housing (not spade terminals), go to Step 3.

On Touring models equipped with two spade terminal connectors in each auxiliary lamp housing, go to Step 4.

4. If using original auxiliary lens/bulb assemblies, cut off Delphi 2-place connector in original lamp housing about 2 inches from connector end. Save connector with wire ends for later splicing to new lamp housing wires.
5. See Figure 2. *For FLHRS models:* Remove and discard original mounting screws (1). Repeat for other side. Remove handlebar mounted turn signals, acorn nuts, internal tooth washers, signals, and mounting blocks from handlebars. Install original acorn nuts and internal tooth washers to secure mirrors.
6. Remove headlamp and headlamp bucket. Refer to HEADLAMP in Service Manual.

NOTE

Be sure to label or mark all wires before cutting them to ensure proper installation and function of kit. Be sure to cut wires in places easily concealed for a clean kit installation.

7. Locate turn signal connectors and auxiliary lamp connectors. Refer to ELECTRICAL CONNECTOR LOCATIONS in Service Manual.
8. Label, cut, and strip wires (purple, blue, black and gray for auxiliary lamps), prior to installing kit.

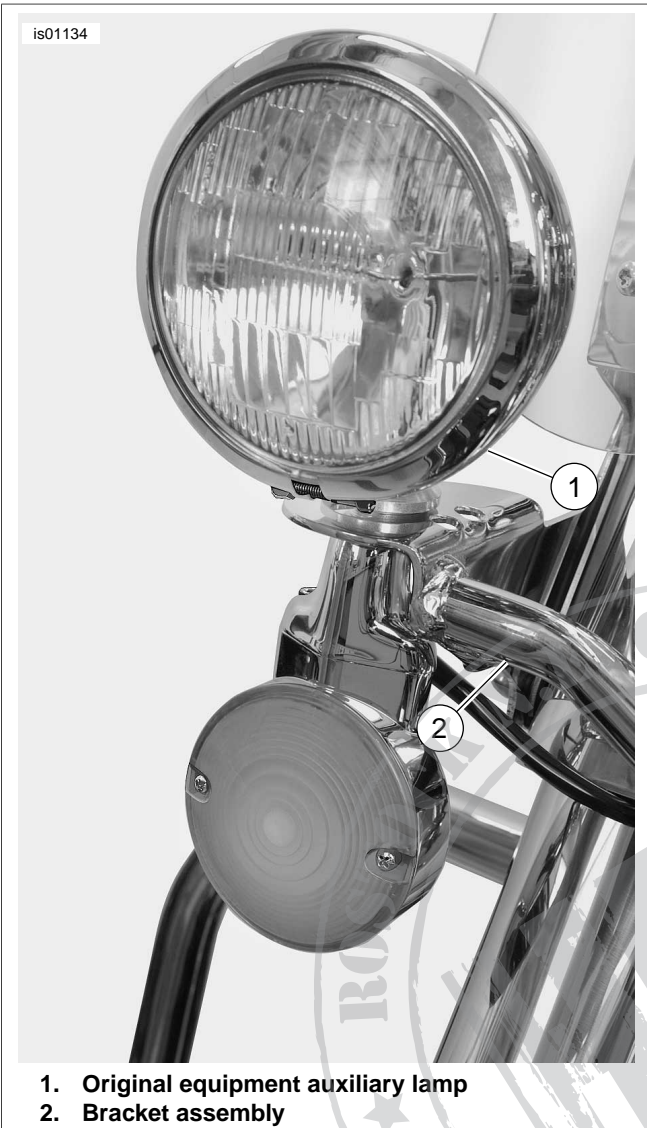

Figure 1. Original Equipment Auxiliary Lamp Assembly (Typical)

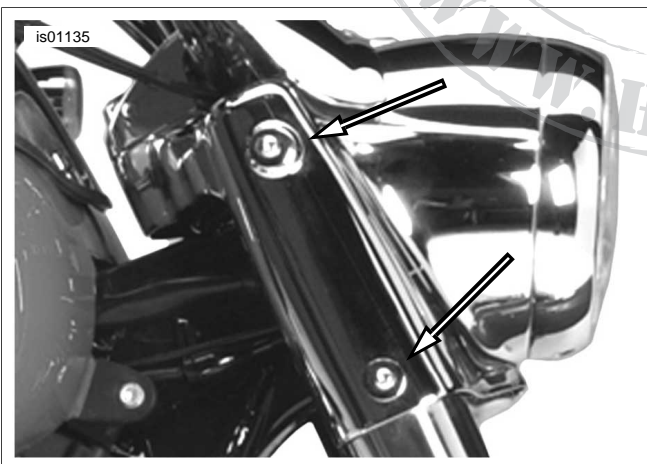

Figure 2. Typical Mounting Screw Locations (FLHRS)

ASSEMBLY

NOTE

The Custom Auxiliary Lighting Kit must be assembled before installation on motorcycle.

1. See Figure 9. Install lamp housing (1), rubber washer (2), clamp block (3), and lamp bracket (4). Secure with lockwasher (5) and nylon locknut (6). Tighten locknut to 14-18 ft-lbs (19-24 Nm). Repeat for other side.
2. Tie small knot in terminal end of gray wire from lamp housing (1) approximately 3-4 inches from terminal to avoid wire getting pulled too far into housing during installation.
3. See Figure 3. Insert bare end of gray wire through hole in mounting stud on auxiliary lamp housing (1) and through larger passage in lamp bracket until knot in terminal end of wire bottoms in socket housing (2).



Figure 3. Auxiliary Lamp Wire Routing

4. See Figure 9. Install turn signal assembly (A) to stand off (7) by routing wires through directional stand off and passage in lamp bracket (4) along side gray wire (Figure 4). Secure turn signal assembly using lockwasher (8) and screw. (9). Tighten to 96-120 in-lbs (10.8-13.6 Nm). Repeat for other side.

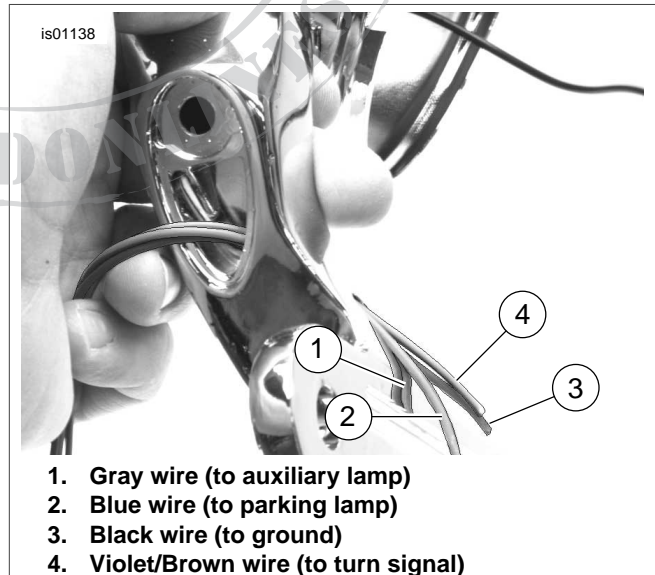

Figure 4. Turn Signal Wire Routing

5. See Figure 5. Install wire sheathing (1) onto wires (2). Insert a small amount of silicone into passage (3) of lamp

bracket and firmly slide sheathing into passage and allow to dry before installing.

- See Figure 9. After silicone has dried, place a cable tie (14) from kit approximately 1 inch from sealed area, and clinch around sheathing to secure it in place.

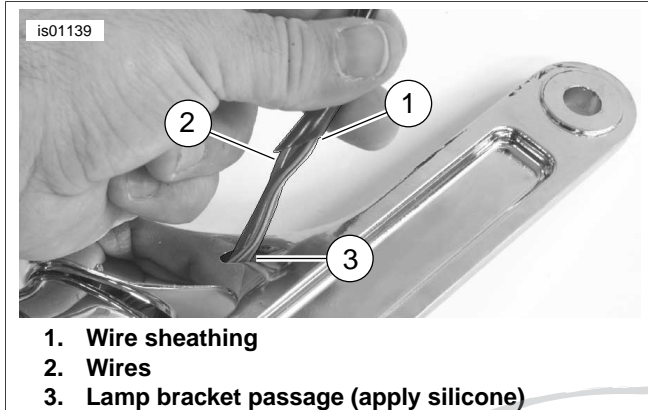

Figure 5. Install Wire Sheathing

INSTALLATION

FLHT Models

- See Figure 6. Hold left side lamp bracket (1) in mounting position on motorcycle. Install two TORX screws (2) and washers (3) into lamp bracket (1) and attach to motorcycle. Tighten screws to 12-16 ft-lbs (16-22 Nm). Repeat for right side.

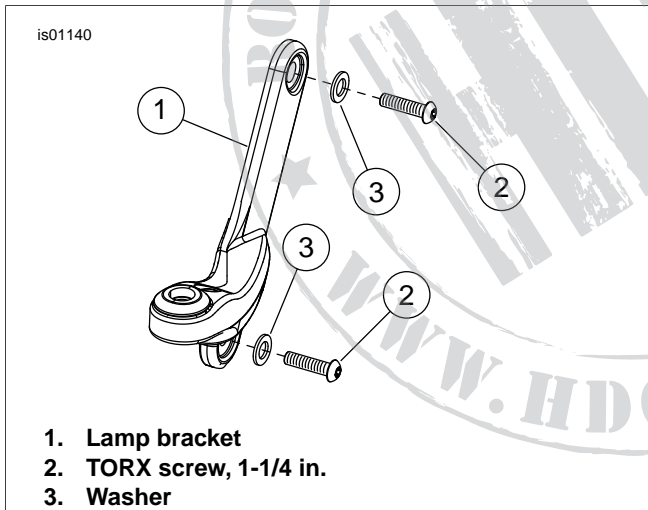

Figure 6. Lamp Bracket Assembly (FLHT)

- See Figure 9. Connect wires from lamp assembly to wires previously labeled or marked on motorcycle using butt splice connectors (18) from kit. Refer to SEALED BUTT SLICE CONNECTORS in Service Manual for instructions to splice wires.

NOTES

When connecting wires from kit to existing wires, match colors to colors (i.e. purple wire to purple wire). Refer to appropriate wiring schematic if questions arise.

On 2006 and later FLHT models, if using original lens/bulb assemblies equipped with Delphi 2-place connectors, go to Step 3.

If using auxiliary lamps with spade connectors, go to "Final Assembly" subtopic.

- Cut both spade terminals from new accessory lamp as close to the terminal as possible.
- Using butt splice connectors (18) from kit, connect positive (gray/black) wire and ground (black) wire from new lamp housing to same wires on 2-place Delphi connector cut from original lamp housing. Refer to SEALED BUTT SLICE CONNECTORS in Service Manual for instructions to splice wires.

FLHR/FLHRS Models With Windshield

NOTES

FLHR and FLHRS models equipped with a windshield will require the separate purchase of Hardware Kit 69235-04 which includes three 1-1/2 in. bolts and one 1-3/4 in. bolt.

FLHRS models can be made "windshield ready" with the additional purchase of Hardware Kit 69234-04 which includes three 1-1/2 in. bolts, one 1-3/4 in. bolt, and four docking bushings.

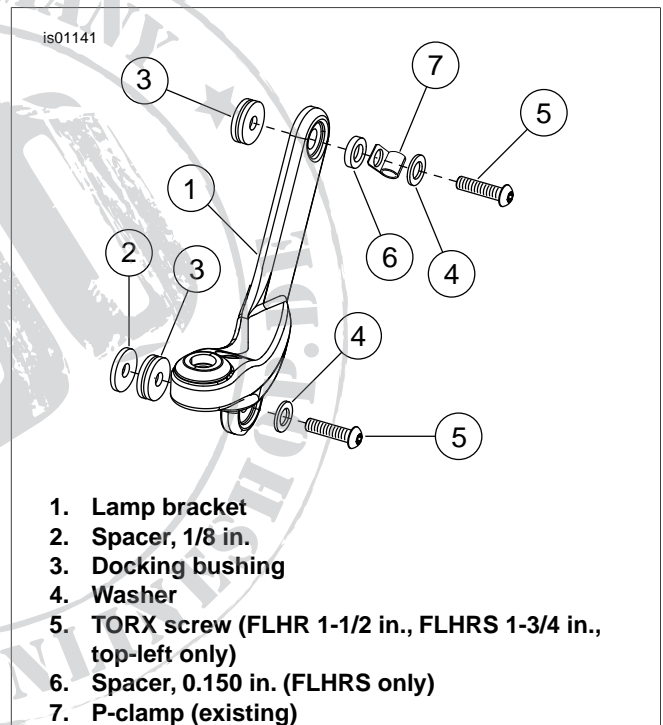

Figure 7. Lamp Bracket Assembly (FLHR/S) With Windshield

- For FLHR models: See Figure 7. Hold left side lamp bracket (1) in mounting position on motorcycle. Install 1/8 in. spacer (2), docking bushing (3), washer (4), and 1-1/2 in. TORX screw (5) in top and bottom locations. Tighten screws to 12-16 ft-lbs (16-22 Nm). Repeat for right side.

For FLHRS models: See Figure 7. Hold left side lamp bracket (1) in mounting position on motorcycle. Install 1/8 in. spacer (2), docking bushing (3), washer (4), and 1-1/2 in. TORX screw (2). Pivot lamp bracket upward. Install docking bushing (3), 0.150 in. spacer (6), clutch cable P-clamp (7), washer (4), and 1-3/4 in. (5). Tighten screws to 12-16 ft-lbs (16-22 Nm).

NOTE

For right side, use 1/8 in. spacer (2), washer (4), and 1-1/2 in. TORX screw (5) at top and bottom locations. Tighten screws to 12-16 ft-lbs (16-22 Nm)

2. See Figure 9. Connect wires from lamp assembly to wires previously labeled or marked on motorcycle using butt splice connectors (18) from kit. Refer to SEALED BUTT SLICE CONNECTORS in Service Manual for instructions to splice wires.

NOTES

When connecting wires from kit to existing wires, match colors to colors (i.e. purple wire to purple wire). Refer to appropriate wiring schematic if questions arise.

On 2006 and later FLHT models, if using original lens/bulb assemblies equipped with Delphi 2-place connectors, go to Step 3.

If using auxiliary lamps with spade connectors, go to "Final Assembly" subtopic.

3. Cut both spade terminals from new accessory lamp as close to the terminal as possible.
4. Using butt splice connectors (18) from kit, connect positive (gray/black) wire and ground (black) wire from new lamp housing to same wires on 2-place Delphi connector cut from original lamp housing. Refer to SEALED BUTT SLICE CONNECTORS in Service Manual for instructions to splice wires.

FLHRS Models Without Windshield

1. See Figure 8. Hold left side lamp bracket (1) in mounting position on motorcycle. Install 1/8 in. spacer (2) washer (3), 1-1/4 in. TORX screw (4). Pivot lamp bracket upward. Install 0.150 in. spacer (5) into upper lamp bracket recess. Install clutch cable P-clamp (6), washer (3), and 1-1/2 in. TORX screw (4). Tighten screws to 12-16 ft-lbs (16-22 Nm).

NOTE

For right side, use 1/8 in. spacer (2), washer (3), and 1-1/4 in. TORX screw (4) at top location and bottom locations. Tighten screws to 12-16 ft-lbs (16-22 Nm).

2. See Figure 9. Connect wires from lamp assembly to wires previously labeled or marked on motorcycle using butt splice connectors (18) from kit. Refer to SEALED BUTT SLICE CONNECTORS in Service Manual for instructions to splice wires.

NOTE

When connecting wires from kit to existing wires, match colors to colors (i.e. purple wire to purple wire). Refer to appropriate wiring schematic if questions arise.

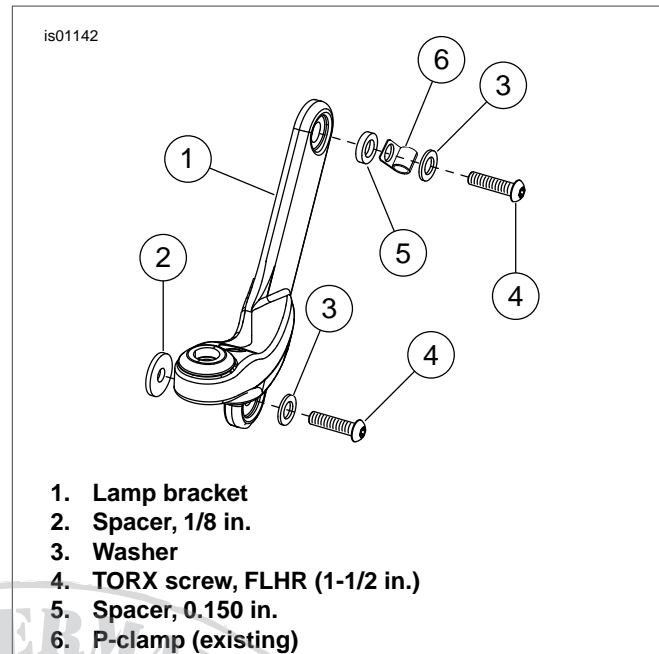

Figure 8. Lamp Bracket Assembly (FLHRS) Without Windshield

Final Assembly

1. See Figure 9. Connect and install lamp sealed beams, lens/bulb assemblies, and trim rings using nest rings (12) from kit.
2. Verify all lighting components and switches function properly before operating vehicle.

WARNING

Connect positive (+) battery cable first. If positive (+) cable should contact ground with negative (-) cable connected, the resulting sparks can cause a battery explosion, which could result in death or serious injury. (00068a)

3. 2003-Earlier Models:
 - a. Connect battery cables, positive (-) cable first. Refer to BATTERY in Service Manual.
 - b. Install seat according to the instructions in the Service Manual.

WARNING

After installing seat, pull upward on seat to be sure it is locked in position. While riding, a loose seat can shift causing loss of control, which could result in death or serious injury. (00070b)

4. 2004-Later Models:
 - a. Remove left side cover and maxi-fuse. Refer to SYSTEM FUSES in Service Manual.
 - b. Install left side saddlebag. Refer to SADDLEBAG INSTALLATION in Service Manual.

SERVICE PARTS

is03870

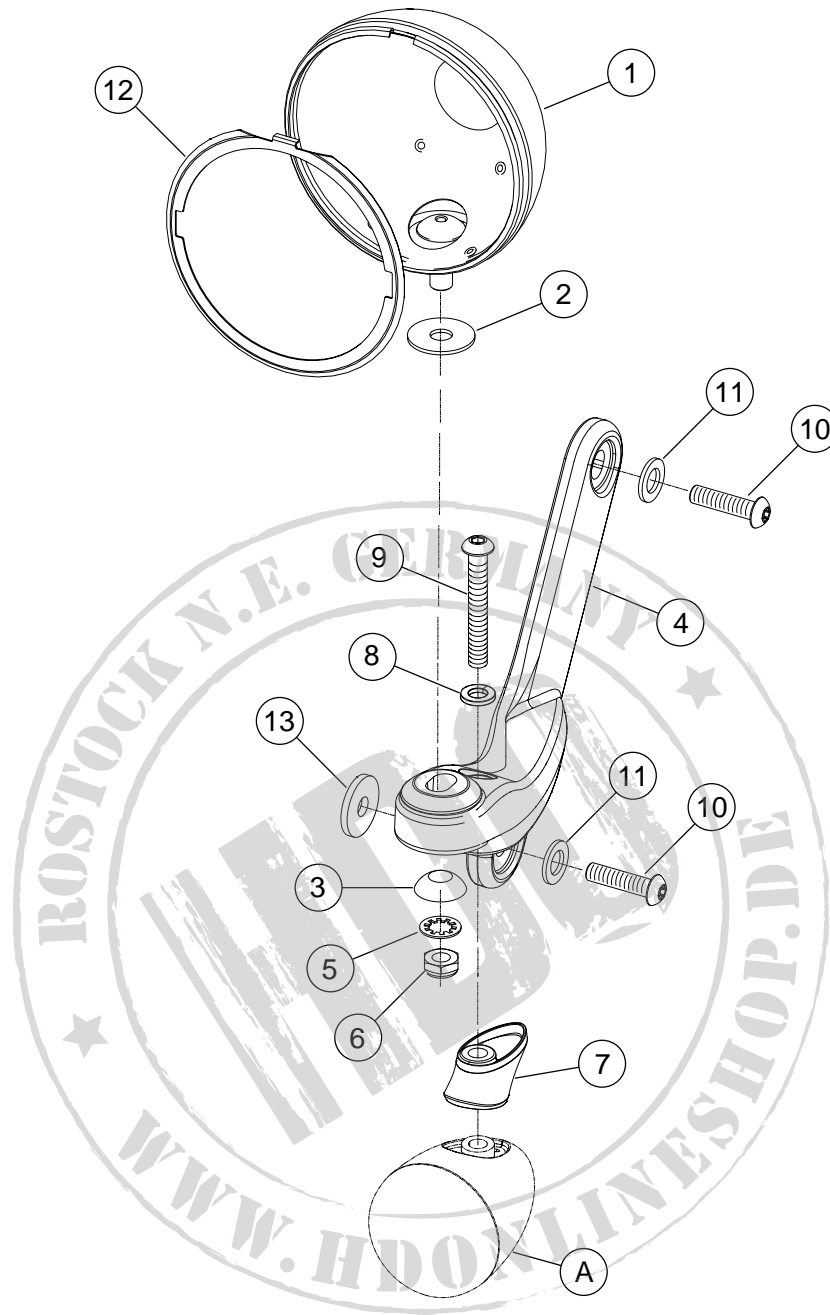

Figure 9. Service Parts: Custom Auxiliary Lighting Kit

Table 1. Service Parts: Custom Auxiliary Lighting Kit

Item	Description (Quantity)	Part Number
1	Lamp housing, auxiliary (chrome) (2)	68822-04
2	Washer, rubber (2)	40901-05
3	Clamp block (2)	69563-06
4	Bracket, auxiliary lamp, left side	Not Sold Separately
	Bracket, auxiliary lamp, right side (Not Shown)	Not Sold Separately
5	Lockwasher, 3/8 in. (2)	7041
6	Locknut, Nylon 3/8 in. (2)	7667
7	Stand-off, directional (2)	68821-00

Table 1. Service Parts: Custom Auxiliary Lighting Kit

Item	Description (Quantity)	Part Number
8	Lockwasher, 5/16 in. (2)	7130W
9	Screw, hex socket head, 5/16-18 x 2-1/4 in. (2)	4296
10	Screw, TORX button head 5/16-18 x 1-1/4 in. (4)	94602-98
11	Washer, flat 7/16 in. (4)	57920-04
12	Ring, nest (2)	68331-02
13	Washer, flat 3/8 in. (2)	6645
14	Cable tie (4) (Not Shown)	10181
15	Screw, TORX button head 5/16-18 x 1-1/2 in. (Not Shown)	4784
16	Spacer, clamp (Not Shown)	65832-92
17	Sheathing, black vinyl (2) (Not Shown)	Not Sold Separately
18	Connector, butt splice (12) (Not Shown)	70585-93
Items mentioned in text, but not included in kit:		
A	Turn signal assembly, left and right (purchased separately)	

