



# INSTRUCTIONS

-J05884

2013-06-13

## LED HEADLAMP ADAPTER HARNESS

### GENERAL

#### Kit Number

69200897

#### Models

For model fitment information, see the P&A Retail Catalog or the Parts and Accessories section of [www.harley-davidson.com](http://www.harley-davidson.com) (English only).

#### Additional Parts Required

##### ▲ WARNING

The rider's safety depends upon the correct installation of this kit. Use the appropriate service manual procedures. If the procedure is not within your capabilities or you do not have the correct tools, have a Harley-Davidson dealer perform the installation. Improper installation of this kit could result in death or serious injury. (00333a)

##### NOTE

- This instruction sheet references service manual information. A service manual for your model motorcycle is required for this installation and is available from a Harley-Davidson dealer.
- The body control module (BCM) must be programmed .

#### Kit Contents

See Figure 2 and Table 1.

### REMOVAL

##### ▲ WARNING

To prevent accidental vehicle start-up, which could cause death or serious injury, remove main fuse before proceeding. (00251b)

1. Remove the main fuse. Follow the instructions in the service manual.
2. Remove the headlamp. Follow the instructions in the service manual.
3. Disconnect the OEM headlamp jumper harness from the main harness. Discard jumper.

### INSTALLATION

#### Fairing Models

1. The two capped wires are not used. Secure to the jumper harness with electrical tape.
2. Connect the LED adapter harness to the main harness connector.

##### NOTE

The fourth wire on the LED adapter harness is not used in all cases. It is for the position light on some headlamps.

3. Follow the instruction included with the new LED headlamp to connect and finish headlamp installation.
4. Install main fuse. Follow the instructions in the service manual.

#### Road King Models

1. Cut the OEM harness connectors off. If the vehicle may be returned to halogen lighting at a later date, leave enough wire at the connectors to allow splicing.
2. See Figure 2. Cut off connector (4) from the adapter harness.

##### NOTE

The blue wire on the LED adapter harness is not used in all cases. Wrap with electrical tape to insulate.

3. **HDI models:** Cut off the sealed caps (5). If the original headlamp was not equipped with a position lamp, do not cut off the sealed caps.
4. See Figure 1. Strip and splice the wires following the sealed splice connector procedure in the service manual.
  - a. Match wire colors.
  - b. Use the blue splice connectors for the 16 ga wires that were cut from connector (4).
  - c. **HDI models:** Use the red splice connectors for the blue and black 20 ga wires that connect to the position lamp on certain models.
5. Follow the instructions included with the new LED headlamp to connect and finish headlamp installation.
6. Install main fuse. Follow the instructions in the service manual.



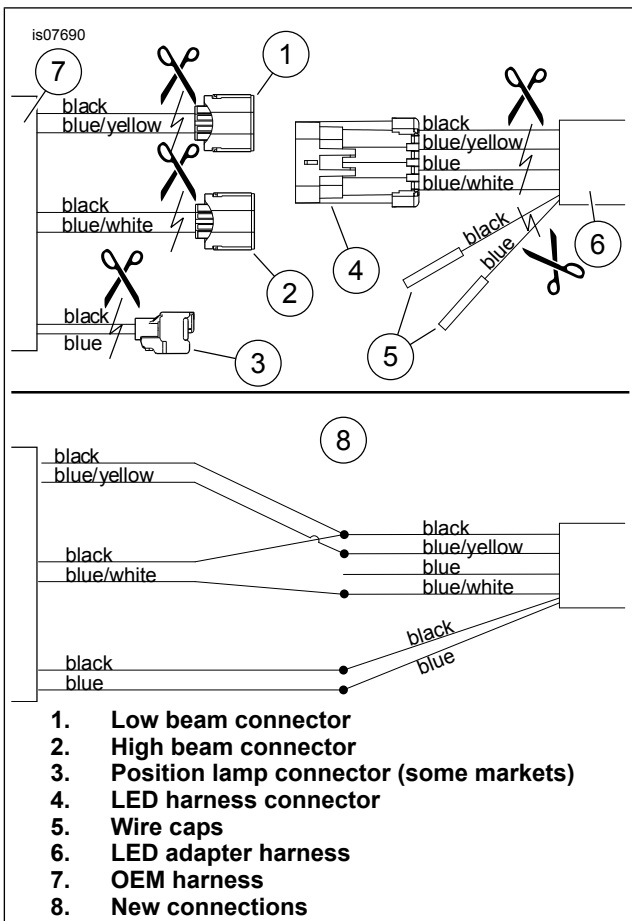

Figure 1. Reconfigure Harness: FLHR/C

## FINALIZE INSTALLATION

### ⚠ WARNING

Be sure headlamp, tail and stop lamp and turn signals are operating properly before riding. Poor visibility of rider to other motorists can result in death or serious injury. (00478b)

1. Verify headlamp operation: Direct optic LED: Reflective optic LED:
  - a. **High beam:** Only the lower globe and both side lamps should light.
  - b. **Low beam:** Only the upper globe and both side lamps should light.
  - a. **High beam:** Only the lower globe and center bar & shield should light.
  - b. **Low beam:** Only the upper globe and center bar & shield should light.
2. Follow the instructions in the service manual to align the headlamp.

## SERVICE PARTS

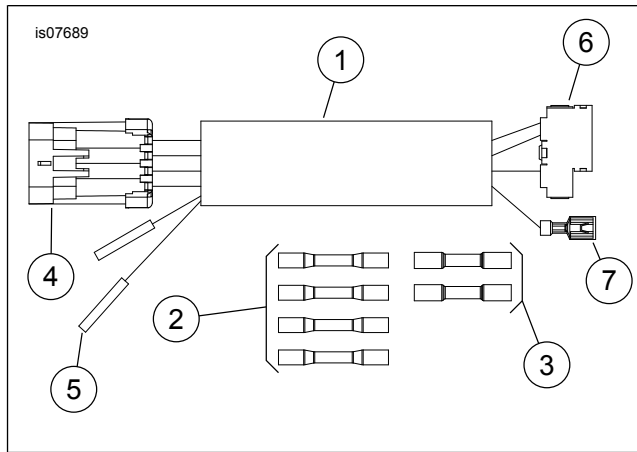

Figure 2. Service Parts: LED Headlamp Harness Adapter Kit

Table 1. Service Parts: LED Headlamp Harness Adapter Kit

Item	Description (Quantity)	Part Number
1	Headlamp adapter harness (includes items 4-7)	69200881
2	Connector, blue (4)	70586-93
3	Connector, red (2)	70585-93
4	Connector, 4-way	
	• Housing	69200255
	• Secondary lock	69200256
	• Terminal, pin (4)	72608-08
	• Seal (4)	72214-94
5	Wire cap (2)	not serviced
6	Connector, 3-way	
	• Housing	72056-92
	• Terminal, LH (2)	9848
	• Terminal, RH (1)	9847
7	Connector, spade	9907