



# INSTRUCTIONS

-J05287

2010-08-19

## DETACHABLE TOUR-PAK HARNESS KIT

### GENERAL

#### Kit Number

69200181

#### Models

For model fitment information, see the P&A retail catalog or the Parts and Accessories section of [www.harley-davidson.com](http://www.harley-davidson.com) (English only).

#### Additional Parts Required

Prior or concurrent installation of a Detachable Tour-Pak® Rack Kit (Part No. 53246-09A) is required for proper installation of this Harness Kit.

#### Tools and Supplies Required

A Deutsch Terminal Crimp Tool (Part No. HD-39965) is required for the proper installation of this kit.

#### ▲ WARNING

The rider's safety depends upon the correct installation of this kit. Use the appropriate service manual procedures. If the procedure is not within your capabilities or you do not have the correct tools, have a Harley-Davidson dealer perform the installation. Improper installation of this kit could result in death or serious injury. (00333a)

#### NOTE

This instruction sheet refers to service manual information. A service manual for this year/model motorcycle is required for this installation and is available from a Harley-Davidson dealer.

### Kit Contents

See Figure 4 and Table 1.

### INSTALLATION

#### Preparation

#### NOTE

**For vehicles equipped with security siren:**

- Verify that the Hands-Free Fob is present.
- Turn the ignition key switch to IGNITION.

#### ▲ WARNING

To prevent accidental vehicle start-up, which could cause death or serious injury, remove main fuse before proceeding. (00251b)

1. Refer to the service manual and follow the instructions to remove the main fuse.

2. Follow the service manual instructions to remove the saddlebags and seat. Retain all seat mounting hardware.

#### Tour-Pak Removal

#### NOTE

Electrical connectors are identified in the service manual by the number and letter shown here within brackets.

1. Disconnect the left-side and right-side rear speakers (circuits [41] and [42]).
  - a. Disengage the grommet surrounding the speaker wire harness on one of the speaker boxes.
  - b. Carefully pull the harness from the speaker box until the six-way Deutsch connector is exposed.
  - c. Disconnect the pin housing on the harness from the socket housing on the speaker. Let the socket housing remain outside the hole in the speaker box, but install the grommet back into the opening.
  - d. Tuck the pin housing and harness into the area under the seat.
  - e. Repeat for the remaining speaker.
2. Remove the passenger headset harness retaining spring assembly.
  - a. Grasp the cable strap on the end of the vinyl spring sleeve on the passenger headset harness.
  - b. Unhook the sleeve and the end of the spring from the tab at the upper right of the license plate holder.
  - c. Unhook the other end of the spring from the tab near the headset receptacle on the passenger headset harness. The spring assembly can be discarded.
  - d. Release the headset harness from the clip on the underside of the left-side speaker box, and temporarily tuck it into the area under the seat.
3. Open the Tour-Pak lid and remove all items from the Tour-Pak base.
4. Open the map pocket and remove the acorn nuts with flat washers. Remove the map pocket and liner.
5. Disconnect the AM/FM antenna cable [29B] from the antenna base cable [29A] inside the Tour-Pak. Disconnect the CB antenna cable [50C] from the CB antenna cable extension [50D] inside the Tour-Pak. Leave the cable extension connected to the CB antenna base stud and ground. Release both antenna cables from the adhesive clips at the bottom of the Tour-Pak.

6. Disconnect the Tour-Pak lighting three-way Multilock socket housing [12B] from vehicle main harness pin housing [12A] inside the Tour-Pak.
7. Pull the left- and right-side grommets (A and B) into the Tour-Pak, and remove them from the Tour-Pak lighting harness, AM/FM antenna cable and CB antenna cable. Feed the antenna cables and Tour-Pak lighting branch of the vehicle main harness out through the grommet holes.
8. Remove the left and right side covers. Coil the antenna cables into the space inside the covers.
9. See Figure 4. Connect the Tour-Pak quick-disconnect wire harness (15) pin housing (D) to socket housing [12B] inside the Tour-Pak.
10. Install the AM/FM antenna jumper cable from the Detachable Tour-Pak Kit by threading the knurled nut onto the Tour-Pak AM/FM antenna base. Tighten the nut securely.
11. Lay the AM/FM antenna jumper cable so that the cable rests flat on the bottom of the Tour-Pak. Secure the cable in the wire clips on the floor of the Tour-Pak.
12. Feed the Tour-Pak lighting jumper harness and AM/FM antenna jumper cable out through the grommet hole on the front left side of the Tour-Pak.

**NOTE**

*DO NOT connect the Tour-Pak lighting jumper harness socket housing (E) to vehicle main harness pin housing [12A].*

*DO NOT connect the AM/FM antenna jumper cable to vehicle AM/FM antenna cable [29B].*

13. Install the grommet (A) onto the AM/FM antenna jumper cable and the Tour-Pak lighting jumper harness near the hole in the Tour-Pak. Carefully work the grommet into the hole to seal the opening around the cable and harness.
14. Install the CB antenna jumper cable (10) by plugging the CB antenna cable extension into the female end of the jumper.
15. Lay the CB antenna jumper cable so that the cable rests flat on the bottom of the Tour-Pak. Secure the cable in the wire clips on the floor of the Tour-Pak. Route the other end forward and through the grommet hole on the front right side of the Tour-Pak.

**NOTE**

*DO NOT connect the CB antenna jumper cable to vehicle CB antenna cable [50C].*

16. Install the grommet (B) onto the CB antenna jumper cable near the hole in the Tour-Pak. Carefully work the grommet into the hole to seal the opening around the cable.

**NOTE**

*The CB antenna mast (C) and the AM/FM antenna mast are similar in appearance and are marked "AM/FM" and "CB" (see Figure 1 ). The masts are not interchangeable.*

**NOTE**

*Have a firm grasp on the Tour-Pak as the bolts and washers are removed.*

17. Remove the CB antenna mast and AM/FM antenna mast and set them aside.

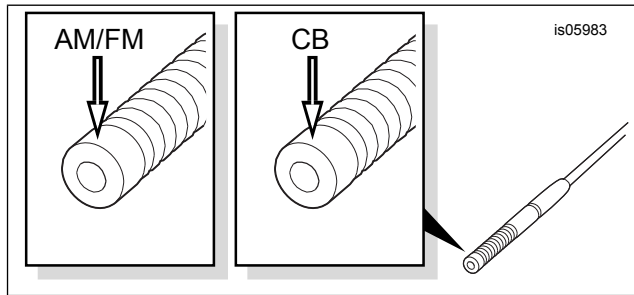
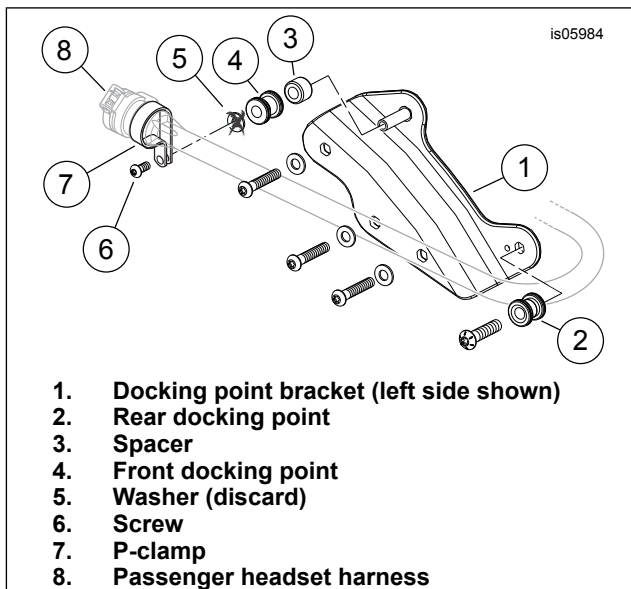

**Figure 1. Antenna Mast Identification**

18. Remove the four bolts and washers from inside the Tour-Pak. Remove the Tour-Pak from the motorcycle.
19. Follow the instructions in the Detachable Tour-Pak Rack Kit to remove the following items:
  - a. Passenger grab strap.
  - b. Forward saddlebag brackets.
  - c. Rear fender supports.
  - d. Luggage rack-to-fender support fasteners.

## Rack and Docking Point Installation

1. Follow the instructions in the Detachable Tour-Pak Rack Kit to perform the following installations:
  - a. Install the rack to the Tour-Pak.
  - b. See Figure 2. Install the docking point brackets (1) to the motorcycle.
  - c. Install the forward and rear docking points to the right-side bracket. Install the **rear** docking point (2) to the left-side bracket.
  - d. Install the spacer (3) and front docking point (4) onto the pin.



1. Docking point bracket (left side shown)
2. Rear docking point
3. Spacer
4. Front docking point
5. Washer (discard)
6. Screw
7. P-clamp
8. Passenger headset harness

Figure 2. Communication Port Installation

2. Retrieve the passenger headset harness (8) from the area under the seat. Route the harness back along the fender, inboard of the left-side docking point bracket, then out and forward **underneath** both docking points.
3. Obtain the P-clamp (7) from **this** kit. Insert the communication port at the end of the passenger headset harness into the loop of the P-clamp, and fasten the clamp to the pin with the screw (6). The flat washer (5) can be discarded.
4. Follow the instructions in the Detachable Tour-Pak Rack Kit to perform the following installations:
  - a. Install the license plate holder and reflector to the vehicle.
  - b. Install the forward saddlebag brackets and grab strap to the vehicle.

### AM/FM Antenna Base and Bracket Mounting to Fender

1. Follow the instructions in the Detachable Tour-Pak Rack Kit to install the AM/FM antenna cable and bracket to the left-side saddlebag support with the following exceptions:
  - a. See Figure 4. Use the AM-FM antenna bracket (3, Part No. 76228-09) from **this** kit instead of the bracket (Part No. 76557-09) from the Detachable Tour-Pak Rack Kit.
  - b. Complete the AM/FM antenna installation only up to the point where the antenna mast is installed. DO NOT install the antenna mast at this time.

### CB Antenna Base and Bracket Mounting to Fender

**NOTE**

See Figure 4. To allow for maximum thread engagement of the CB antenna/cable adapter (5), position the nuts (7) on the CB antenna base (joint assembly) (6) to leave nearly all of the 1/2-20 thread **above** the upper nut.

1. See Figure 3. Install the inner (5) and outer (6) CB antenna bracket clamps around the saddlebag guard (8), and install four screws (7). Tighten the screws finger-tight.
2. Install one of the 1/2-20 nuts (3) from the kit onto the CB antenna base (1), followed by the large internal tooth lockwasher (4). Insert the large threads of the base downward through the hole in the antenna mounting bracket.
3. Install the second 1/2-20 nut onto the antenna base threads. Place a wrench on the upper nut and tighten the lower nut to 5.4–10.8 N·m (4–8 ft-lbs).
4. Obtain the male-ended CB antenna cable (Figure 4, Item 9) from **this** kit. Plug the 90 degree end connector into the underside of the antenna base (Figure 3, Item 1) on the antenna bracket (5). Tighten the knurled nut to secure the connector to the base. Allow slack in the cable at the antenna base to avoid kinking or binding at the connection.
5. Route the jumper cable up the saddlebag support bar, forward along the underside of the fender support cover and over to the right side cover.

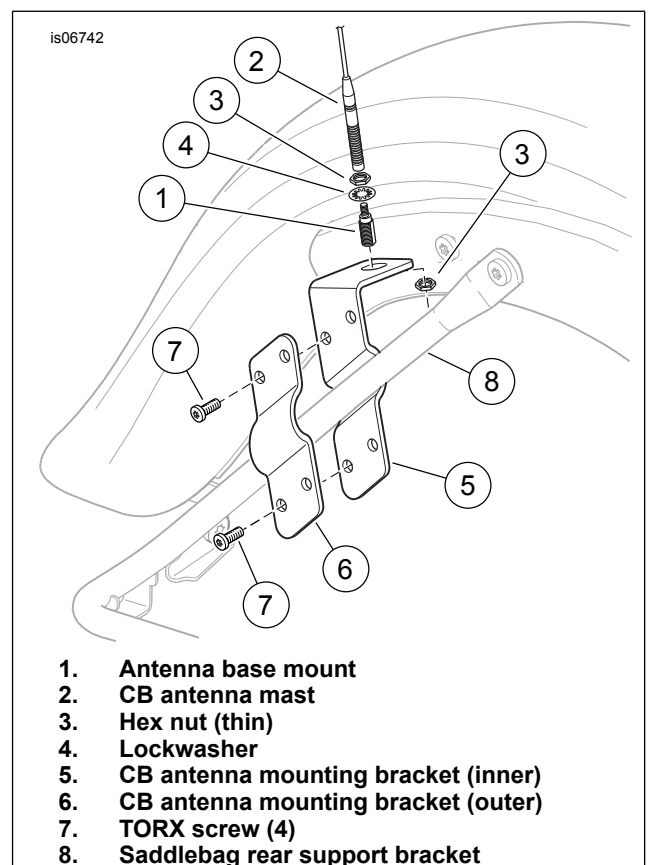

1. Antenna base mount
2. CB antenna mast
3. Hex nut (thin)
4. Lockwasher
5. CB antenna mounting bracket (inner)
6. CB antenna mounting bracket (outer)
7. TORX screw (4)
8. Saddlebag rear support bracket

Figure 3. CB Antenna Bracket Mounting to Fender

6. See Figure 4. Fasten the antenna cable to the saddlebag support bar with a cable strap (12) from the kit. Use a second cable strap to tie the antenna cable to the frame rail, near the suspension air lines, underneath the chrome cover. DO NOT secure the cable to the air lines.
7. Retrieve the open end of the Ultra audio interconnect harness CB antenna cable disconnected from the Tour-Pak and stored under the right side cover in an earlier step.

#### NOTE

The CB antenna mast and the AM/FM antenna mast are similar in appearance. See Figure 1.

8. Connect the CB antenna jumper cable to the audio interconnect harness CB antenna cable. Coil the excess cable and tie with a cable strap from the kit. Stow the coiled cable under the cover.
9. See Figure 3. Install the CB antenna mast (2) securely onto the right-side antenna base (1). Install the AM/FM antenna mast securely onto the left-side antenna base.
10. Align the CB antenna parallel with the radio antenna. Adjust the position of the CB antenna bracket clamp location if necessary. Tighten the four bracket clamp mounting screws to 4.5–6.7 N·m (40–60 **in-lbs**).

## RETURN TO SERVICE

#### NOTE

To prevent possible damage to the sound system, verify that the ignition key switch is in the OFF position **before** installing the main fuse.

1. Refer to the service manual and follow the instructions to install the main fuse.
2. Test the AM/FM radio and CB for proper operation.
3. Cap the unused Tour-Pak lighting three-way Multilock pin housing [12A] on the vehicle main harness with the three-way socket housing from the Detachable Tour-Pak Rack Kit.
4. Apply protective tape to the rear saddlebag mounting brackets on the saddlebags per the instructions in the Detachable Tour-Pak Rack Kit.
5. Install the saddlebags per the instructions in the service manual.

#### ▲ WARNING

**After installing seat, pull upward on seat to be sure it is locked in position. While riding, a loose seat can shift causing loss of control, which could result in death or serious injury. (00070b)**

6. Refer to the service manual and follow instructions to install the seat, with the following exception: Use the seat hardware (13) from **this** kit in place of the original hardware.
7. Install the left and right side covers.

## IN SERVICE

### To Install the Tour-Pak and Relocate the Antenna Masts

1. Remove the CB antenna mast and AM/FM antenna mast from the fender brackets, and set them aside.
2. Install the Tour-Pak and rack to the docking points per the instructions in the Detachable Tour-Pak Rack Kit.

#### NOTE

After installing the Tour-Pak rack, check to be sure the Tour-Pak and rack are secure. The front and rear docking points must be fully engaged.

3. See Figure 4. Thread the CB antenna adapter (5) onto the CB antenna mount joint assembly (6). Plug the free end of the CB antenna jumper cable (10) from the right front of the Tour-Pak onto the top of the antenna adapter (5), and tighten the knurled nut to secure the connector.
4. Thread the AM/FM antenna adapter onto the AM/FM antenna mount joint assembly. Plug the free end of the AM/FM antenna jumper cable from the left front of the Tour-Pak onto the top of the antenna adapter, and tighten the knurled nut to secure the connector.
5. Connect the three-way Multilock socket housing (E) on the Tour-Pak lighting jumper harness to pin housing [12A] on the vehicle main harness.
6. Retrieve the six-way Deutsch pin housings of the Ultra audio interconnect harness (circuits [41] and [42]) from the area under the seat. Connect to the socket housings from the speaker harnesses.

#### NOTE

The CB antenna mast and the AM/FM antenna mast are similar in appearance. See Figure 1.

7. Install the CB antenna mast and AM/FM antenna mast to the Tour-Pak.

### To Remove the Tour-Pak and Relocate the Antenna Mast

1. Disconnect the CB antenna jumper cable and AM/FM antenna jumper cable from the antenna adapters on the top of the fender antenna brackets, leaving them attached to the Tour-Pak.
2. Disconnect the three-way Multilock socket housing [12B] on the Tour-Pak lighting jumper harness from pin housing [12A] on the vehicle main harness, leaving it attached to the Tour-Pak.
3. Disconnect the six-way Deutsch socket housings of the speaker harnesses from the pin housings of the Ultra audio interconnect harness (circuits [41] and [42]).
4. Remove the CB antenna mast and AM/FM antenna mast from the Tour-Pak, and set them aside.
5. Remove the Tour-Pak and rack from the docking points per the instructions in the Detachable Tour-Pak Rack Kit.

#### NOTE

The CB antenna mast and the AM/FM antenna mast are similar in appearance. See Figure 1.

6. See Figure 4. Unthread the CB antenna adapter (5) from the CB antenna mount joint assembly (6) and save for later Tour-Pak installation. Thread the CB antenna mast (C) onto the top of the antenna mount joint assembly.
7. Unthread the AM/FM antenna adapter from the AM/FM antenna mount joint assembly and save for later Tour-Pak installation. Thread the AM/FM antenna mast onto the top of the antenna mount joint assembly.

#### NOTE

Store the antenna jumper connectors and antenna mast adapters inside the Tour-Pak when not in use.

If the Tour-Pak regularly remains off the vehicle for long periods of time, consider separate purchase of the following

items (available from a Harley-Davidson dealer) to prevent deterioration of the electrical connections due to dirt and corrosion.

To protect the lighting connector **on the vehicle** while the Tour-Pak is removed:

- Socket housing, three-way, Part No. 74113-98BK

- (3) Seal pins, Part No. 74195-98

To protect the lighting connector **on the Tour-Pak** while in storage:

- Pin housing, three-way, Part No. 74103-98BK
- (3) Seal pins, Part No. 74195-98

## SERVICE PARTS

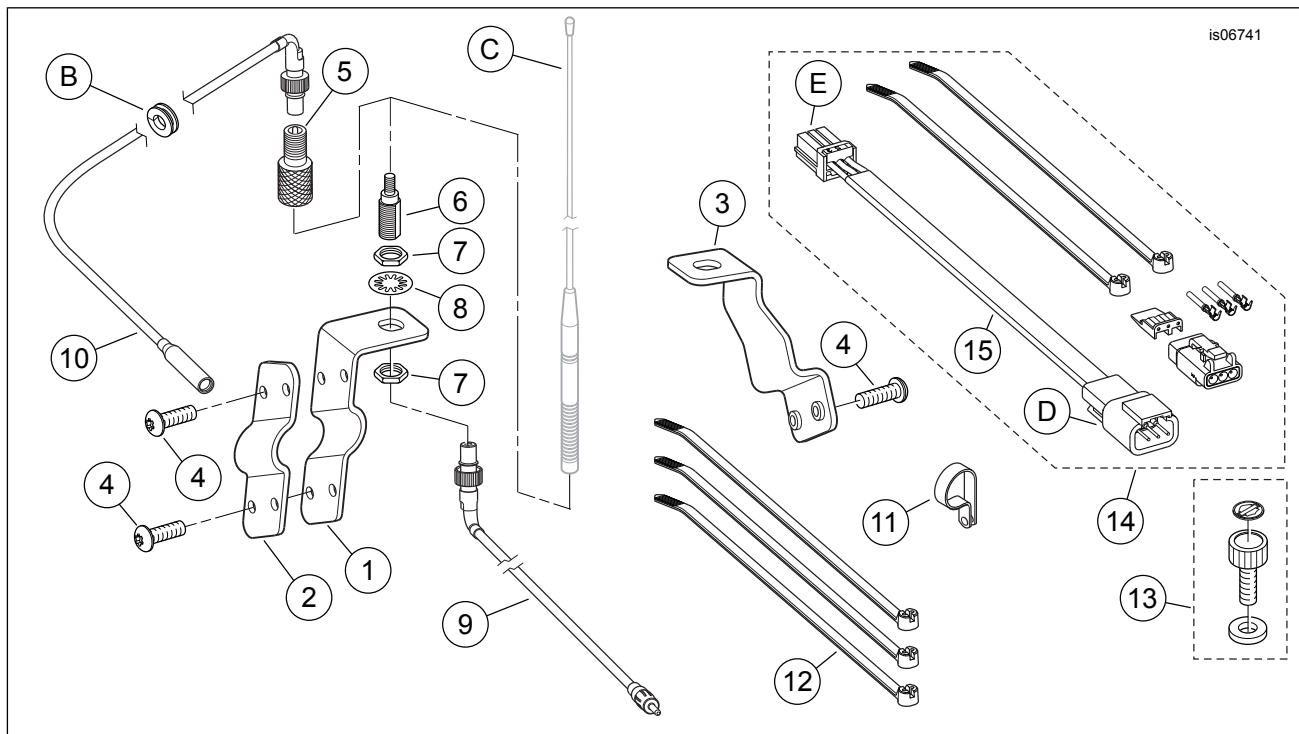

Figure 4. Service Parts, Ultra Detachable Tour-Pak Harness Kit

Table 1. Service Parts

Item	Description (Quantity)	Part Number
1	Bracket, CB antenna mounting (inner)	76411-09
2	Bracket, CB antenna mounting (outer)	76413-09
3	Bracket, AM/FM antenna mounting	76228-09
4	Screw, TORX® pan head, #10-24 x 12.7 mm (½ in) long (6)	2441
5	Adapter, antenna/cable	76219-00
6	Antenna base (joint)	76354-00
7	Hex nut, thin, 1/2-20 (2)	76353-00
8	Lock washer, internal tooth, 1/2 inch	7129
9	Cable assembly, CB antenna (male end, vehicle to bracket)	76505-09
10	Cable assembly, CB antenna (female end, Tour-Pak to bracket)	76506-09
11	Clamp, P-type (1/2 inch)	10053
12	Cable strap (3)	10006
13	Detachable Passenger Seat Hardware Kit	51676-97A
14	Detachable Tour-Pak Light Harness Kit (includes item 15)	70113-08
15	• Wire harness, Tour-Pak quick-disconnect	Not sold separately
<b>Items mentioned in text, but not included in kit:</b>		
A	Grommet, Tour-Pak wire hole, left (not shown)	
B	Grommet, Tour-Pak wire hole, right	
C	CB antenna mast	
D	Tour-Pak quick-disconnect harness pin housing	
E	Tour-Pak quick-disconnect harness socket housing	