



INSTRUCTIONS

-J00434

REV. 2006-09-11

FRONT DIRECTIONAL LIGHT RELOCATION KIT

GENERAL

Kit Number

68517-94A

Models

For model fitment information, please see the P&A Retail Catalog or the Parts and Accessories section of www.harley-davidson.com (English only).

Additional Parts Required

WARNING

The rider's safety depends upon the correct installation of this kit. Use the appropriate service manual procedures. If the procedure is not within your capabilities or you do not have the correct tools, have a Harley-Davidson dealer perform the installation. Improper installation of this kit could result in death or serious injury. (00333a)

NOTE

This instruction sheet references Service Manual information. A Service Manual for your model motorcycle is available from a Harley-Davidson Dealer.

Kit Contents

See Figure 3 and Table 1.

INSTALLATION

NOTE

This kit contains the components needed to relocate directional lights mounted on the upper fork bracket or handlebars (mirrors) to the bottom fork bracket. On motorcycles equipped with front directional lights with three wires, the third black wire is a ground wire. Check how many wires are connected to the front directional lights and follow the following procedure that applies.

RELOCATING TWO WIRE DIRECTIONAL LIGHTS

1. Support motorcycle on a center stand such that front wheel is raised slightly off the ground.
2. Remove fork tube pinch screw from right side of lower fork bracket.
3. **If directional light is mounted on upper fork bracket**, remove fork tube pinch screw from right side of upper fork bracket. (This is the screw that secures the right directional light.) See Figure 1. **If directional light is mounted on mirror**, remove directional light and mounting hardware. Retain the internal toothed lockwashers (4) and spacer (5).
4. Install acorn nut from kit to retain right mirror. If acorn nut "bottoms" without tightening add the second spacer (3) from kit in the location shown.

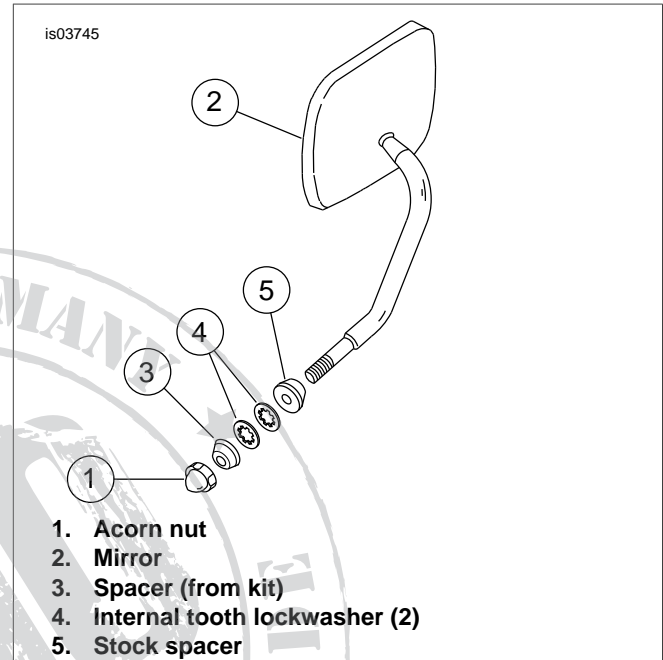

Figure 1. Attaching Mirror

NOTE

Before cutting wires at directional light, remove the directional light, cut cable straps holding wires and check if wires are long enough to reach bottom fork bracket. If wires are too short perform Step 5 otherwise go to Step 6.

5. Cut wires connected to right directional light about 2 inches away from directional light body.

NOTE

If directional light is mounted on upper fork bracket, perform Step 6. **If directional light is mounted on mirror**, refer to Figure 2 and install the directional light mount and then perform Step 6, but, use 3/8-16 x 2.0 inch screw from kit to attach directional light. Disregard reference to upper bracket pinch screw.

6. Install right directional light on right side of lower fork bracket using pinch screw removed in Step 3. Install pinch screw removed in Step 2 into right side of upper bracket. Tighten both pinch screws to 30-35 ft-lbs (41-47 Nm).
7. Repeat Steps 1 through 6 to relocate left directional light. See Figure 1. Use stock acorn nut and internal toothed lockwasher to mount mirror.

NOTE

Fork tubes may slide downward within fork brackets. If this occurs, front fork tube extension above front fork upper bracket will have to be readjusted according to appropriate Service Manual procedures.

8. If wires were cut, connect the right directional light as follows: Strip approximately 5/16 in. insulation from the wires cut in step 5.

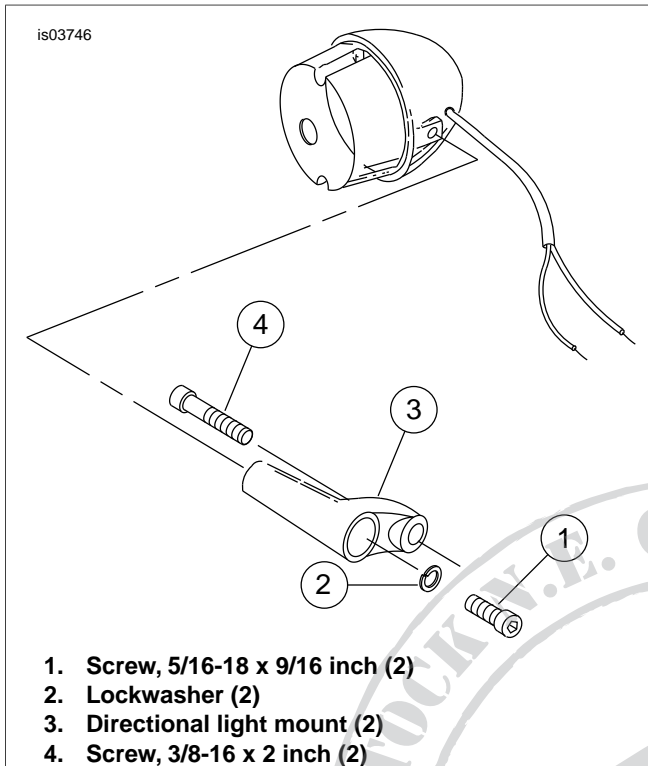

Figure 2. Attaching Directional Light Mount

9. Crimp solderless connectors from kit on two wires coming from motorcycle.
10. Split one end of the 2-conductor polarized wire from kit back about 2 inches and strip 5/16 inch of insulation from wire ends.
11. Slide a piece of shrink tubing from kit over each of the wire ends stripped in Step 10 and crimp the wires into the terminals installed in Step 9. **Make sure you connect the silver and copper colored wires to like colored wires.**

NOTE

Polarized wire is used in this application to ensure correct wiring. One wire is silver, one is copper colored. Wire colors of spliced wire must match wire color of original directional wire leads.

12. Cut polarized wires to the length required for connection to the wires at the relocated directional light. **Make certain you leave enough slack in wires to allow routing the harness along the fork tube.**
13. Split remaining end of the 2-conductor polarized wire from kit back about 2 inches and strip 5/16 inch of insulation from wire ends.
14. Slide heat shrink tubes over the two wire end.
15. Strip 5/16 inch of insulation from wires connected to directional light and connect like colored wires at directional light with connectors from kit.
16. Slide heat shrink tubing over connectors installed in Steps 11 and 15. Activate shrink tubing with UltraTorch UT-100, heat gun or hair dryer.

WARNING

Be sure to follow manufacturer's instructions when using the Robinair Heat Gun or any other radiant heating device. Failure to follow manufacturer's instructions can cause a fire, which could result in death or serious injury. (00379a)

- Avoid directing heat toward any fuel system component. Extreme heat can cause fuel ignition/explosion resulting in death or serious injury.
 - Avoid directing heat toward any electrical system component other than the connectors on which heat shrink work is being performed.
 - Always keep hands away from tool tip area and heat shrink attachment.
17. Position harness along fork tube and secure with cable straps.
 18. Repeat Steps 8 through 17 for left directional light.
 19. Test operation of directional lights and running lights. If operation is not correct, verify that the wire splices were made properly.

RELOCATING THREE WIRE DIRECTIONAL LIGHTS

1. Support motorcycle on a center stand such that front wheel is raised slightly off the ground.
2. Remove fork tube pinch screw from right side of lower bracket.

NOTE

Before cutting wires at directional light, remove the directional light, cut cable straps holding wires and check if wires are long enough to reach bottom fork bracket. If wires are too short perform Steps 3 and 4.

3. Carefully cut off 4 inches of conduit covering the wires connected to right directional light.
4. Cut the directional light wires at the following lengths from the directional light:
 Blue wire- 1-1/4 inches from directional light
 Violet wire- 2-1/4 inches from directional light
 Black wire- 3-1/4 inches from directional light

NOTE

The wires are cut at different lengths to stagger the butt connectors and prevent a large bulge in the harness.

5. Strip 5/16 inch of insulation from the cut ends of the three wires cut in Step 4.
6. Remove fork tube pinch screw from right side of upper fork bracket. (This is the screw that secures the right directional light.)

NOTE

If directional light is mounted on upper fork bracket, perform Step 7. If directional light is mounted on mirror, refer to Figure 2 and install the directional light mount and then perform Step 7, but, use 3/8-16 x 2 inch screw from kit to attach directional light. Disregard reference to upper bracket pinch screw. See Figure 1. Install acorn nut from kit to retain right mirror. If acorn nut "bottoms" without tightening add the second spacer from kit in the location shown.

7. Install right directional light on right side of lower fork bracket using pinch screw removed in Step 6. Install pinch screw removed in Step 2 into right side of upper bracket. Tighten both pinch screws to 30-35 ft-lbs (41-47 Nm).
8. Repeat Steps 1 through 7 to relocate left directional light.

NOTE

Fork tubes may slide downward within fork brackets. If this occurs, front fork tube extension above front fork upper bracket will have to be readjusted according to appropriate Service Manual procedures.

9. If wires were cut, connect right directional as follows: Crimp solderless connectors from kit on three wires coming from motorcycle.
10. Cut a 6 inch length of wire from the black, blue and violet wires in the kit.
11. Strip 5/16 inches of insulation from one end on each of the 6 inch wire lengths, connect like colored wires and crimp into connectors installed in Step 9.
12. Slide shrink tubing from kit over crimped terminals. Activate shrink tubing with heat gun or hair dryer.
13. Cut 8 inches of 5/16 inch ID conduit from conduit supplied with kit.
14. Slide 8 inch length of conduit onto three wires connected in Step 11 and over existing conduit.
15. Cut three spliced-on wires to the lengths required for connection to the wires connected to the directional light. Make certain to leave enough slack to allow routing harness along fork tube.
16. Slide heat shrink tubes over the three wire ends.

17. Strip 5/16 inches of insulation from remaining wire ends and connect like colored wires at directional light with connectors from kit.
18. Slide heat shrink tubing over connectors installed in Steps 10 and 14. Activate shrink tubing with UltraTorch UT-100, heat gun or hair dryer.

⚠ WARNING

Be sure to follow manufacturer's instructions when using the Robinair Heat Gun or any other radiant heating device. Failure to follow manufacturer's instructions can cause a fire, which could result in death or serious injury. (00379a)

- Avoid directing heat toward any fuel system component. Extreme heat can cause fuel ignition/explosion resulting in death or serious injury.
 - Avoid directing heat toward any electrical system component other than the connectors on which heat shrink work is being performed.
 - Always keep hands away from tool tip area and heat shrink attachment.
19. Slide 5/16 inch conduit, installed in Step 14, over all new connections and as close to directional light as possible.
 20. Install a cable strap on the 5/16 inch conduit, next to directional light, to secure conduit in position.
 21. Position harness along fork tube and secure with cable straps.
 22. Repeat Steps 9 through 21 to connect left directional light.
 23. Test operation of directional lights and running lights. If operation is not correct, verify that the wire splices were made properly.

SERVICE PARTS

is03747

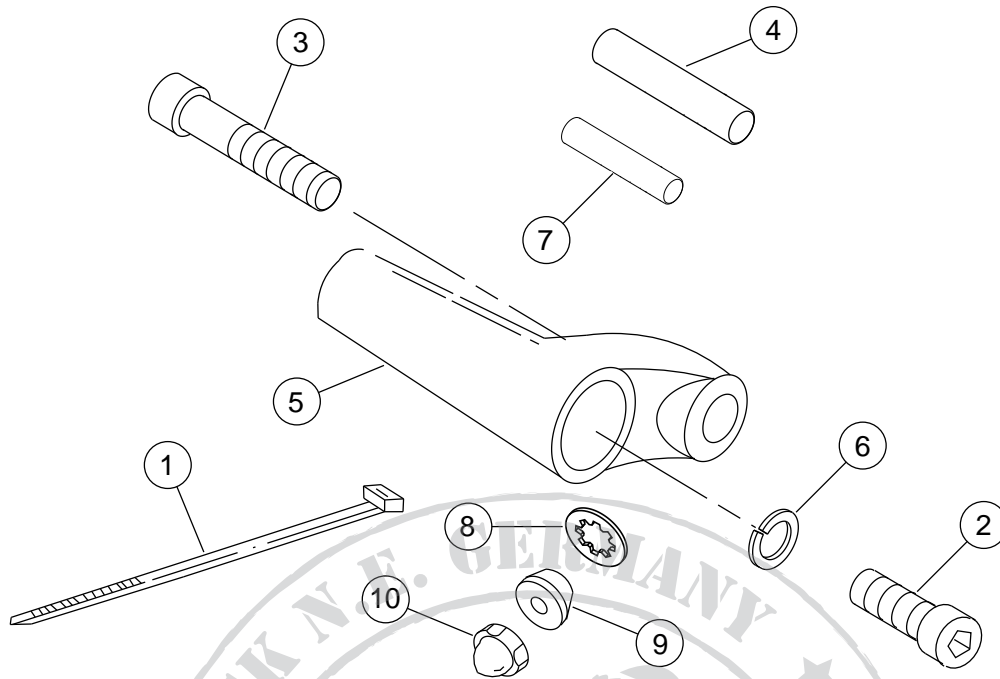

Figure 3. Service Parts: Front Directional Light Relocation Kit

Table 1. Service Parts Table

| Item | Description (Quantity) | Part Number |
|------|--|-------------|
| 1 | Cable strap (6) | 10006 |
| 2 | Screw, 5/16-18 x 9/16 inch (2) | 2698A |
| 3 | Screw, hex socket, 3/8-16 x 2.0 inch (2) | 4047 |
| 4 | Heat shrink tubing (6) | 67113-83 |
| 5 | Directional light mount (2) | 68555-87 |
| 6 | Lockwasher, hicollar (thick) (2) | 7042 |
| 7 | Butt connector (6) | 70581-73 |
| 8 | Lockwasher, internal tooth (mirror) (1) | 7127 |
| 9 | Spacer (mirror) | 5774 |
| 10 | Acorn nut (mirror) | 7736 |