



INSTRUCTIONS

-J03718

REV. 2007-02-09

LED TAIL LAMP WITH BAR & SHIELD LOGO

GENERAL

Kit Numbers

68085-08 (Red lens/Chrome), 68087-08 (Smoke lens/Black), 68086-08 (Smoke lens/Chrome).

Models

For model fitment information, please see the P&A Retail Catalog or the Parts and Accessories section of www.harley-davidson.com (English only).

Kit Contents

See Figure 3 and Table 1.

INSTALLATION

For models WITH maxi-fuse:



To prevent accidental vehicle start-up, which could cause death or serious injury, remove maxi-fuse before proceeding. (00251a)

1. Refer to the Owner's Manual and follow the instructions given to remove the seat and maxi-fuse. Retain all seat mounting hardware.

For models WITHOUT maxi-fuse:



To prevent accidental vehicle start-up, which could cause death or serious injury, disconnect negative (-) battery cable before proceeding. (00048a)

NOTE

For 2004 and later XL (Sportster®) models, the negative battery cable is most easily disconnected at the engine crankcase.

1. Refer to the Owner's Manual and follow the instructions given to remove the seat and disconnect the negative (black) battery cable from the negative (-) battery terminal. Retain all seat mounting hardware.

NOTE

Figure 1 shows the original equipment tail/stop lamp mounted to a full fender. The lamp is rotated 180° when mounted to a Bobtail fender.

2. See Figure 1. Loosen the two Phillips head screws (2) retaining the tail/stop lamp assembly (1) to the lamp base (3), and pull the lamp assembly away from the base.
3. Depress the locking tab (button), and disconnect the tail/stop lamp four-way Multilock socket housing [93B] (4) from the circuit board. Remove the lamp from the vehicle.

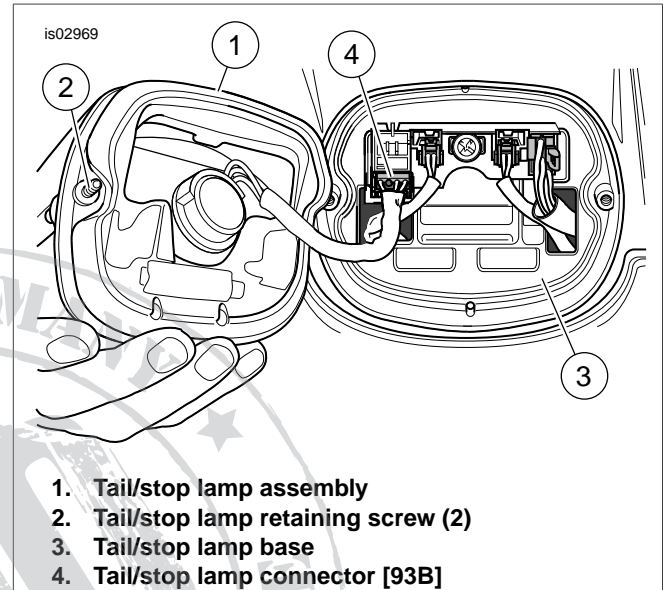

1. Tail/stop lamp assembly
2. Tail/stop lamp retaining screw (2)
3. Tail/stop lamp base
4. Tail/stop lamp connector [93B]

Figure 1. Removing the Tail/Stop Lamp Assembly

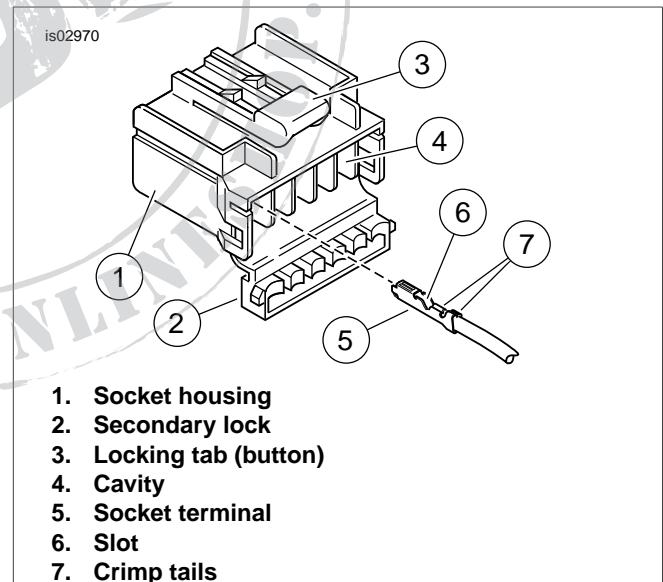

1. Socket housing
2. Secondary lock
3. Locking tab (button)
4. Cavity
5. Socket terminal
6. Slot
7. Crimp tails

Figure 2. Socket Terminal Installation

4. On the new tail/stop lamp assembly, the Blue wire and socket terminal are not installed in the four-way socket housing. Refer to the original lamp removed in Step 3, and observe which cavity contains the Blue wire. Note that the cavities are numbered on the face of the secondary lock. The Blue wire and terminal must be

installed into the **same** cavity in the socket housing of the new lamp as follows:

- See Figure 2. On the secondary lock (2) side of the socket housing (1), position the socket terminal (5) with the slot (6) and crimp tails (7) facing up (in the same direction as the button (3) on the top of the socket housing).
- Insert the terminal into the correct cavity (4) until it snaps into place with an audible "click".
- Gently tug on the wire end to verify that the terminal is locked in place and will not back out of the cavity.
- Rotate hinged secondary lock inward until tabs fully engage the latches on both sides of the connector.

NOTES

If the terminal must be removed and re-installed, refer to the **MULTILOCK ELECTRICAL CONNECTORS** section of a Harley-Davidson Service Manual.

Fill pin cavities in the circuit board with dielectric grease from the packet in the kit before assembling connector halves.

- Connect the socket housing on the **new** tail/stop lamp assembly to the four-way pin housing in the circuit board.

NOTE

Do not over-tighten the screws. Over-tightening the screws can crack the tail/stop lamp lens or result in scratching of the fender paint.

- Install the tail/stop lamp to the vehicle, and alternately tighten the screws to 20-24 **in-lbs** (2.3-2.7 Nm).

NOTE

Lamp assembly (1) attaches as shown on full fender models. On Bobtail models, lamp assembly is rotated 180°. The logo (2) is not factory installed so logo can be installed in the upright position.

- See Figure 3. Peel the liner from the adhesive backing of the Bar & Shield emblem (2) from the kit. Orient the emblem with the logo upright, and carefully position the emblem to the recessed area in the center of the tail/stop lamp lens. Press firmly into place, ensuring that the edge is securely fastened all around.

NOTE

Allow **AT LEAST 24 hours** after applying the emblem before exposing the area to vigorous washing, strong water spray or extreme weather.

CAUTION

Do not over-tighten bolts on battery terminals. Use recommended torque values. Over-tightening battery terminal bolts could result in damage to battery terminals. (00216a)

- Verify that the Ignition/ Light Key Switch is in the OFF position.

Models WITH maxi-fuse: Refer to the Owner's Manual and follow the instructions given to re-install the maxi-fuse.

Models WITHOUT maxi-fuse: Re-connect the negative (-) battery cable per the instructions in the Owner's Manual.

Apply a light coat of petroleum jelly or corrosion retardant material to the negative battery terminal.

Refer to the Owner's Manual, and follow the instructions given to re-install the seat.

WARNING

After installing seat, pull upward on seat to be sure it is locked in position. While riding, a loose seat can shift causing loss of control, which could result in death or serious injury. (00070b)

WARNING

Be sure headlamp, tail and stop lamp and turn signals are operating properly before riding. Poor visibility of rider to other motorists can result in death or serious injury. (00478b)

- Turn the Ignition/ Light Key Switch to ON, but do not start motorcycle. Test for proper tail and stop lamp operation.

SERVICE PARTS

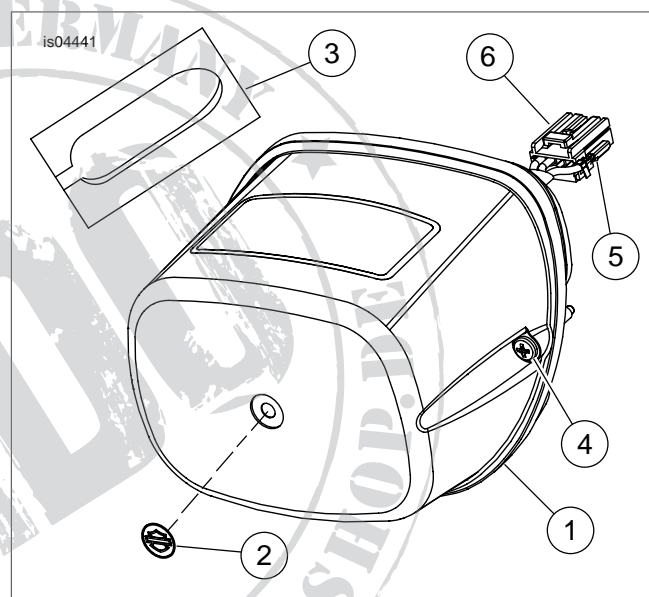

Figure 3. Service Parts: LED Tail Lamp With Bar and Shield Logo

Table 1. Service Parts Table

Item	Description	Part Number
1	Assembly, tail lamp, red lens, chrome	Not sold separately
	Assembly, tail lamp, smoke lens, chrome	Not sold separately
	Assembly, tail lamp, smoke lens, black	Not sold separately
2	Logo (emblem)	Not sold separately
3	Die electric grease	Not sold separately
4	Screw, chrome	68026-99
5	Socket terminal	73191-96
6	Housing, socket, 4-way	73154-96BK