



INSTRUCTIONS

-J04682

REV. 2009-10-23

AIR WING DETACHABLE LUGGAGE RACK LIGHT KITS

GENERAL

Kit Numbers

68065-10, 68219-10

Models

For model fitment information, see the P&A retail catalog or the Parts and Accessories section of www.harley-davidson.com (English only).

WARNING

The rider's safety depends upon the correct installation of this kit. If the procedure is not within your capabilities or you do not have the correct tools, have a Harley-Davidson dealer perform the installation. Improper installation of this kit could result in death or serious injury. (00308a)

NOTE

This instruction sheet refers to service manual information. A service manual for this year/model motorcycle is available from a Harley-Davidson dealer.

Additional Parts Required

This Light Kit is designed to mount to an Air Wing Detachable Luggage Rack. A Detachable Docking Hardware Kit is required for proper installation of the luggage rack.

See the P&A retail catalog or the Parts and Accessories section of www.harley-davidson.com (English only) for these items, and for model fitment information.

Electrical Overload

CAUTION

It is possible to overload your motorcycle's charging system by adding too many electrical accessories. If your combined electrical accessories operating at any one time consume more electrical current than your vehicle's charging system can produce, the electrical consumption can discharge the battery and cause vehicle electrical system damage. See a Harley-Davidson dealer for advice about the amount of current consumed by additional electrical accessories, or for necessary wiring changes. (00211b)

WARNING

When installing any electrical accessory, be certain not to exceed the maximum amperage rating of the fuse or circuit breaker protecting the affected circuit being modified. Exceeding the maximum amperage can lead to electrical failures, which could result in death or serious injury. (00310a)

This Air Wing Luggage Rack Light Kit requires up to **52 mA** additional current from the electrical system.

Kit Contents

See Figure 3 and Table 1.

INSTALLATION

1. If not already in place, install the Detachable Docking Hardware Kit per the instructions in **that** kit.

See Figure 3. If installed, remove the Air Wing Detachable Luggage Rack (A) from the vehicle and place it upside-down on the work surface.

2. Remove the black plastic plugs (B) from the holes at the front and back of the left side rail.
3. Insert the loop end of the nylon monofilament guide wire (8) through the forward hole (C) in the rail, and out through the rear hole (D). Allow the straight end to remain outside the forward hole.
4. Firmly attach the three wires of the light assembly (1) to the loop of the guide wire. Carefully pull the straight end of the guide wire to draw the wires and shrink tubing into and through the rail, and out the forward hole.

Detach the light wires from the guide wire.

NOTE

Ambient temperature should be **at least 60 °F (16 °C)** for proper adhesion of the foam adhesive pads (2) to the rack and light.

Test-fit the light to the rack before installation. Do not remove the pad liners until ready to apply the pads.

5. Clean the foam pad mounting areas (E) on the underside of the rack rear crossbar and (see Figure 1) on the light (3) with a mixture of 50-70% isopropyl alcohol and 30-50% distilled water. Allow to dry thoroughly.

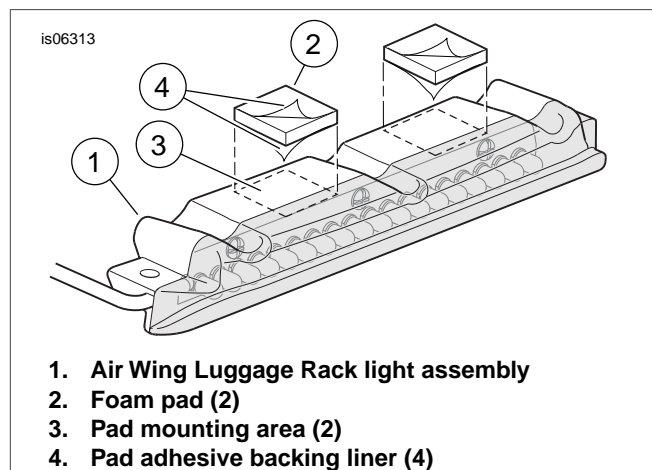

Figure 1. Attach Foam Pads to Light

6. Remove the liner (4) from the adhesive backing on **one side** of a pad (2). Carefully position the pad to the top surface of the light (1), between the clearance notches, and press firmly into place. Repeat with the second pad.
7. See Figure 3. Remove the remaining liner from both pads, and install the light to the rear cross bar with two socket head screws (3) and flat washers (4), drawing the wiring out the forward hole (C) as the light is set in place. Tighten the screws securely.

WIRING

⚠ WARNING

To prevent accidental vehicle start-up, which could cause death or serious injury, remove main fuse before proceeding. (00251b)

1. Refer to the service manual and follow the instructions to remove the seat.

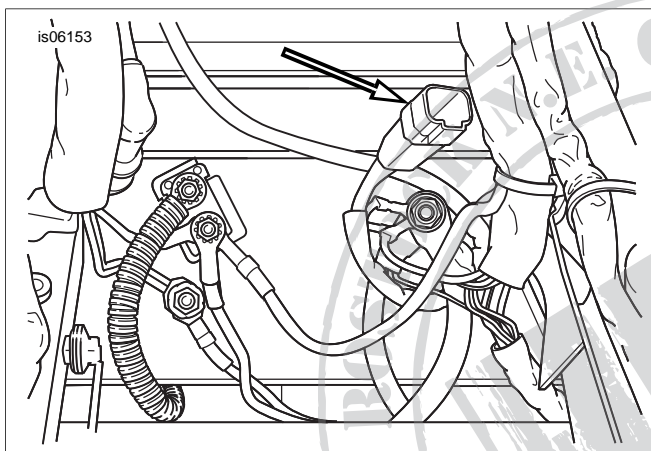

Figure 2. Accessory Connector [4] Location Under Seat

2. Locate the four-way accessory connector [4] in the area under the seat. See Figure 2. Remove the plug from the accessory connector.
Connect the luggage rack light extension wire harness (7) to the accessory connector.

NOTE

If the accessory connector is already in use, a Switched Circuit Adapter Harness (Part No. 70264-94A) is available from a Harley-Davidson dealer to provide an additional connection point.

3. Route the extension harness so the three-way connector can be easily accessed for luggage rack installation and removal.
4. Mount the luggage rack to the docking points on the vehicle per the instructions in the Luggage Rack Kit.

5. Route the light assembly wires along the frame rail to the three-way connector on the luggage rack light extension wire harness. Fasten the light assembly harness to the vehicle with adhesive-backed clips (9) from the kit.
Cut the light assembly wires and shrink tubing to eliminate excess but allow easy connection to the extension harness.
6. Refer to the service manual and follow the instructions to crimp the pin terminals (5) to the three wires of the light assembly harness.
7. Insert the wires and terminals from the light assembly harness into the pin housing (6) from the kit:
 - a. Insert the **blue** wire into cavity 1.
 - b. Insert the **red/yellow** wire into cavity 2.
 - c. Insert the **black** wire into cavity 3.
8. Apply the contents of the dielectric grease packet (11) to the light and extension harness connector terminals.
9. Connect the light assembly harness to the luggage rack light extension wire harness.

RETURN TO SERVICE

1. Refer to the service manual, and follow instructions to install the main fuse.
2. Turn the ignition key switch to IGNITION, but do not start the motorcycle.
Test the luggage rack light **and** the motorcycle lamps for proper operation:
 - a. With the ignition switch on, the LEDs in the luggage rack light should be illuminated, along with the vehicle tail lamp(s).
 - b. When either the brake hand lever or foot pedal are activated, the LEDs in the luggage rack light should noticeably brighten, along with the vehicle stop lamp(s).
 - c. When either turn signal switch is activated, the LEDs in the luggage rack light should remain lit steadily, and not flash.
 - d. Turn the ignition key switch to OFF. The luggage rack light should turn off immediately, along with the vehicle tail lamp(s).

⚠ WARNING

After installing seat, pull upward on seat to be sure it is locked in position. While riding, a loose seat can shift causing loss of control, which could result in death or serious injury. (00070b)

3. Refer to the service manual, and follow instructions to install the seat.

SERVICE PARTS

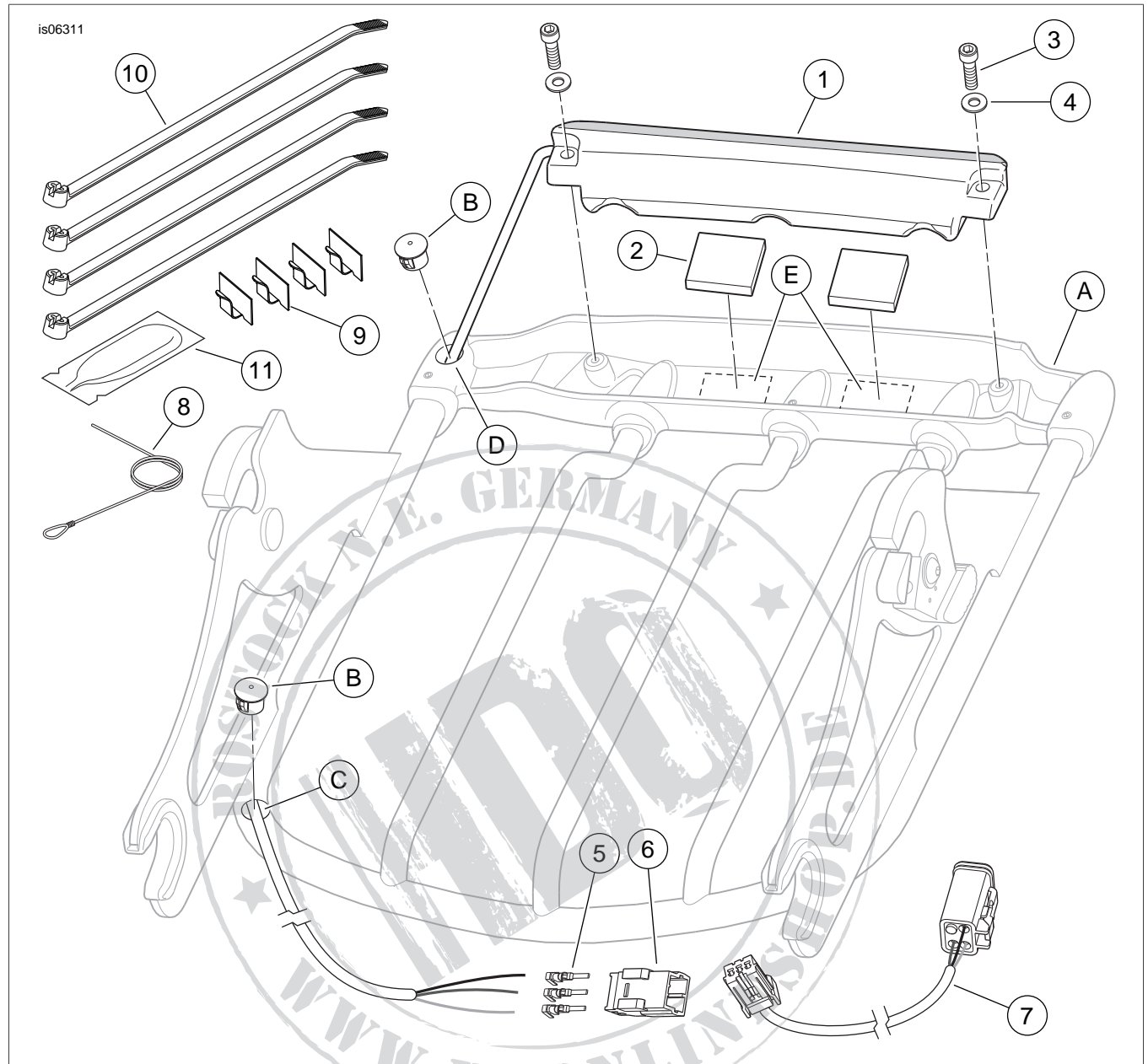

Figure 3. Service Parts, Air Wing Detachable Luggage Rack Light Kits

SERVICE PARTS

Table 1. Service Parts

Item	Description (Quantity)	Part Number
1	Light assembly, Air Wing detachable luggage rack	Not sold separately
2	Foam pad, adhesive both sides (2)	Not sold separately
3	Screw, socket head, #8-32, stainless steel (2)	Not sold separately
4	Flat washer, stainless steel (2)	Not sold separately
5	Pin terminal, 20-16 AWG (3)	73190-96
6	Pin housing, three-way	73103-96BK
7	Wire harness extension, luggage rack light	Not sold separately
8	Guide wire (nylon monofilament), with loop end	Not sold separately
9	Clip, adhesive-backed (4)	10102
10	Cable strap (4)	10006
11	Dielectric grease packet	76001-04
Items mentioned in text, but not included in kit:		
A	Air Wing Detachable Luggage Rack	
B	Plastic plug, black (2)	
C	Forward hole in left side rail	
D	Rear hole in left side rail	
E	Foam pad mounting area (2) on underside of rack rear crossbar	

