



INSTRUCTIONS

-J01707

REV. 2006-06-23

BULLET STYLE TURN SIGNAL RETROFIT KIT

GENERAL

Kit Number

68005-99, 68007-99, 68637-99, 68690-99

Additional Parts Required

⚠ WARNING

The rider's safety depends upon the correct installation of this kit. Use the appropriate service manual procedures. If the procedure is not within your capabilities or you do not have the correct tools, have a Harley-Davidson dealer perform the installation. Improper installation of this kit could result in death or serious injury. (00333a)

NOTE

This instruction sheet references Service Manual information. A Service Manual for your model motorcycle is required for this installation and is available from a Harley-Davidson Dealer.

Kit Contents

See Figure 8 and Table 2.

INSTALLATION

1. Disconnect the battery cables, negative cable first.

⚠ WARNING

To prevent accidental vehicle start-up, which could cause death or serious injury, disconnect battery cables (negative (-) cable first) before proceeding. (00307a)

⚠ WARNING

Disconnect negative (-) battery cable first. If positive (+) cable should contact ground with negative (-) cable connected, the resulting sparks can cause a battery explosion, which could result in death or serious injury. (00049a)

2. Refer to the applicable Service Manual section covering Amp Multilock Electrical Connectors. Remove front left and right turn signal wiring from connectors. Remove turn

signals from existing mounts. Make note of cable strap locations for use when installing new signal wiring in place.

Left Side Swivel Mount

1. Remove acorn nut and lockwasher holding left side rear view mirror in place, but do not remove mirror.
2. See Figure 1. Assemble ball receptacle (4) onto end of rear view mirror using lockwashers (5) placed below receptacle, and original acorn nut. A dimple on the ball receptacle will fit over a small bump on the underside of the clutch lever housing when the receptacle is properly aligned.
3. Place ball stud (3) through ball stud clamp (2) and thread on jamnut (6). Screw ball stud assembly into left side lamp housing. Tighten jamnut against lamp housing.
4. Attach lamp housing to handlebar housing by screwing ball stud clamp onto receptacle. Point turn signal straight ahead then tighten ball stud clamp securely to hold lamp in place.

Right Side Swivel Mount

5. Remove acorn nut and lockwasher holding right side rear view mirror in place, but do not remove mirror.
6. Place remaining lockwasher (5) over end of rear view mirror, then screw retainer (1) onto end of mirror to hold mirror in place.
7. Place ball stud (3) through ball stud clamp (2) and thread on jamnut (6). Screw ball stud assembly into right side lamp housing. Tighten jamnut against lamp housing.
8. Attach lamp housing to handlebar housing by screwing ball stud clamp onto receptacle. Point turn signal straight ahead then tighten ball stud clamp securely to hold lamp in place.
9. Route wiring from kit to connector locations and cut wires to length. Following applicable instructions from Service Manual, install terminals to wires and install to connectors. Mate connectors and install cable and install cable straps from kit at original locations.

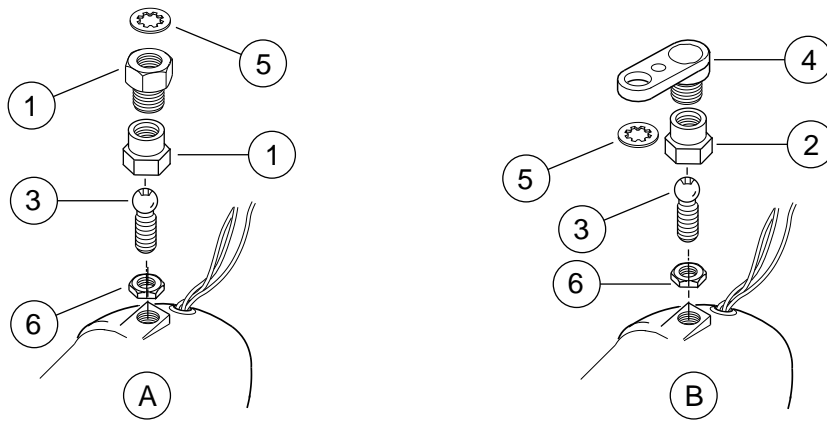

Figure 1. Install Front Swivels and Turn Signals

Table 1. Front Swivels and Turn Signals Kit

Right Side		Left Side	
Item	Description (Quantity)	Item	Description (Quantity)
1	Retainer, mirror/directional	2	Clamp, ball stud
2	Clamp, ball stud	3	Mount, ball stud
3	Mount, ball stud	4	Ball, receptacle
5	Lockwasher	5	Lockwasher
6	Nut, hex jam	6	Nut, hex jam

INSTALL REAR TURN SIGNALS

XL Models (1990 and later when equipped with Airfoil Style Supports)

NOTES

For XL models equipped with Tube-Style Supports, See Figure 5 for installation instructions.

Prior to removing turn signal wires, carefully note routing. In particular pay close attention to the locations of the cable straps which must be replaced.

When removing turn signal wiring, refer to appendix in applicable Service Manual covering detailed procedures for Amp Multilock Electrical Connectors.

1. Remove Turn Signal Wiring according to the following:

1998 and Earlier Models; Remove seat and disconnect connector halves at connector [7]. Following instructions in applicable Service Manual, remove left and right turn signal wiring from connectors.

1999 and Later Models; Remove left and right turn signal 2-pin connectors from circuit board (inside rear tail lamp). Following instructions in applicable Service Manual, remove left and right turn signal wiring from connectors.

2. See Figure 2. Remove left and right turn signals from supports and discard. Save mounting hardware for installation.

3. Pull wiring through conduit and remove from housing.

4. Lay old turn signal lamp housing next to replacement housing from kit and cut new wires to length.
5. Route wiring through new support and fender.
6. See Figure 2. Install support stud through strut cover using hardware removed in Step 2.
7. Install lamp housing to support and tighten securely.

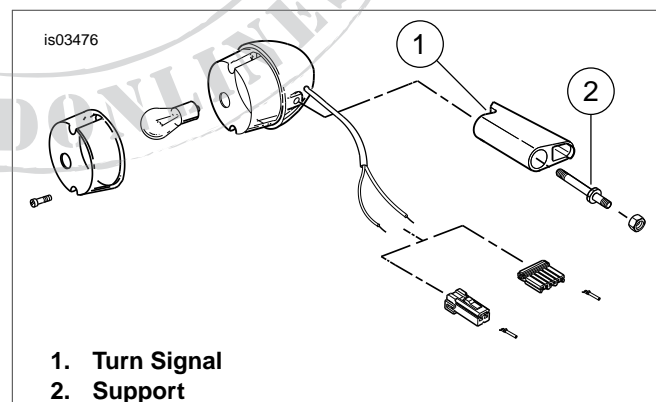

Figure 2. Rear Turn Signal (Typical Airfoil Style Support)

NOTES

When performing the next step, use Terminal P/N 72039-71 for 1995 and earlier models. Use Terminal P/N 73191-96 for 1996 and later models.

When performing the next step on 1994 and earlier models, terminate the ground wire (Black) using ring terminal P/N 9858 and secure to ground screw or other suitable location. For

power wire, use terminal as described in previous note and route following same path as original.

- Following instructions in Service Manual covering Amp Multilock Electrical Connectors, crimp new terminals on wires from kit.
- Thread wires back along taillight conduit and install cable straps to original locations.
- 1998 and Earlier Models;** Insert terminals into connector [7] (under seat). Mate connector halves.
1999 and later Models; Insert terminals into 2-pin connectors. Install connectors to circuit board (inside rear tail lamp).
- Connect battery cables, positive cable first.

⚠ WARNING

Connect positive (+) battery cable first. If positive (+) cable should contact ground with negative (-) cable connected, the resulting sparks can cause a battery explosion, which could result in death or serious injury. (00068a)

- Install seat, if removed.

⚠ WARNING

After installing seat, pull upward on seat to be sure it is locked in position. While riding, a loose seat can shift causing loss of control, which could result in death or serious injury. (00070b)

- Check turn signals for proper operation.

⚠ WARNING

Be sure headlamp, tail and stop lamp and turn signals are operating properly before riding. Poor visibility of rider to other motorists can result in death or serious injury. (00478b)

Dyna Models (1991 and later when equipped with Airfoil Style Supports)

NOTES

For Dyna Models equipped with Tube-Style Supports, See Figure 5 for installation instructions.

When removing turn signal wiring, refer to appendix in applicable Service Manual covering detailed procedures for Amp Multilock Electrical Connectors.

Prior to removing turn signal wires, carefully note routing. In particular pay close attention to the locations of cable straps which must be replaced.

- Remove Turn Signal Wiring according to the following:
1998 and Earlier Models; Remove seat and disconnect connector halves at connector [7]. Following instructions in applicable Service Manual, remove left and right turn signal wiring from connectors.
1999 and Later Models; Remove left and right turn signal 2-pin connectors from circuit board (inside rear tail lamp). Following instructions in applicable Service Manual, remove left and right turn signal wiring from connectors.

- See Figure 3. Remove the existing lamp support by removing the bolt and washer (if present) inside rear fender, then remove the lamp housing from the support. Save hardware for installation. Discard support.
- Pull wiring through conduit and remove from housing.
- Lay old turn signal lamp housing next to replacement housing from kit and cut new wires to length.
- Route wiring through new support and into fender along same path as original.

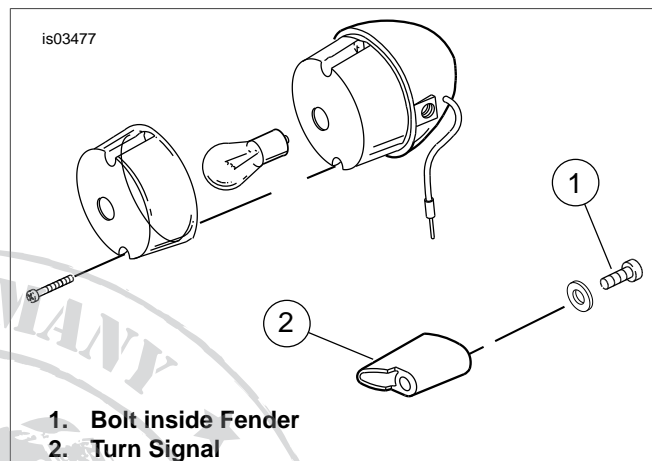

Figure 3. Dyna Rear Turn Signal (Typical Airfoil Style Support)

NOTES

When performing the next step, use Terminal P/N 72039-71 for 1995 and earlier models. Use Terminal P/N 73191-96 for 1996 and later models.

When performing the next step on 1994 and earlier models, terminate the ground wire (Black) using ring terminal P/N 9858 and secure to ground screw or other suitable location. For power wire, use terminal as described in previous note and route following same path as original.

- Following instructions in Service Manual covering Amp Multilock Electrical Connectors, crimp new terminals onto wires from kit.
- Install new lamp housing and support using hardware saved during removal. Tighten both securely.
- Thread wires back along taillight conduit and install cable straps to original locations.
- 1998 and Earlier Models;** Insert terminals into connector [7] (under seat). Mate connector halves.
1999 and later Models; Insert terminals into 2-pin connectors. Install connectors to circuit board (inside rear tail lamp).
- Connect battery cables, positive cable first.

⚠ WARNING

Connect positive (+) battery cable first. If positive (+) cable should contact ground with negative (-) cable connected, the resulting sparks can cause a battery explosion, which could result in death or serious injury. (00068a)

- Install seat, if removed.

WARNING

After installing seat, pull upward on seat to be sure it is locked in position. While riding, a loose seat can shift causing loss of control, which could result in death or serious injury. (00070b)

12. Check turn signals for proper operation.

WARNING

Be sure headlamp, tail and stop lamp and turn signals are operating properly before riding. Poor visibility of rider to other motorists can result in death or serious injury. (00478b)

Softail Models (when equipped with Airfoil Style Supports)

NOTES

For Softail models equipped with Tube-Style Supports, See Figure 5 for installation instructions.

Prior to removing turn signal wires, carefully note routing. In particular, pay close attention to the locations of cable straps which must be replaced.

When removing turn signal wiring, refer to appendix in applicable Service Manual covering detailed procedures for Amp Multilock Electrical Connectors.

1. Remove Turn Signal Wiring according to the following:
 - 1998 and Earlier Models;** Remove seat and disconnect connector halves at connector [7]. Following instructions in applicable Service Manual, remove left and right turn signal wiring from connectors.
 - 1999 and Later Models;** Remove left and right turn signal 2-pin connectors from circuit board (inside rear tail lamp). Following instructions in applicable Service Manual, remove left and right turn signal wiring from connectors.
2. Pull wiring through conduit and remove from housing.
3. See Figure 4. Remove lamp housing from turn signal support, then remove support. Save hardware for installation. Discard support.
4. Lay old turn signal lamp housing next to replacement housing from kit and cut new wires to length.
5. Route wiring through new support and into fender along same path as original.

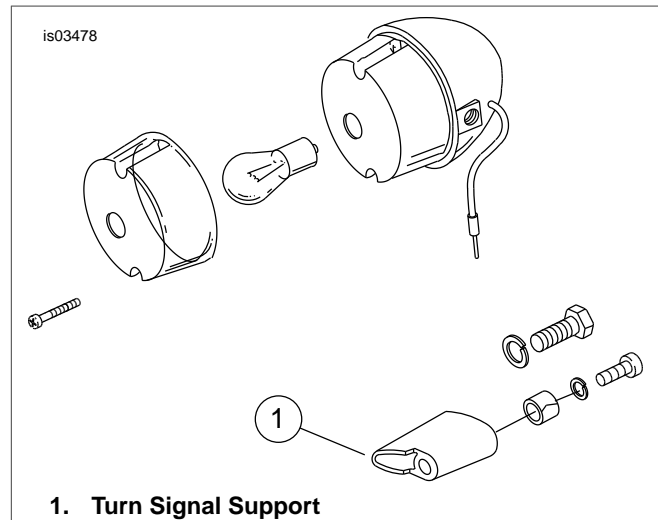

Figure 4. Softail Rear Turn Signal (Typical Airfoil Style Support)

NOTES

When performing the next step, use P/N 72039-71 for 1995 and earlier models. Use Terminal P/N 73191-96 for 1996 and later models.

When performing the next step on 1994 and earlier models, terminate the ground wire (Black) using ring terminal P/N 9858 and secure to ground screw or other suitable location. For power wire, use terminal as described in previous note and route following same path as original.

6. Following instructions in Service Manual covering Amp Multilock Electrical Connectors, crimp new terminals onto wires from kit.
7. Install new lamp housing and support using hardware saved during removal. Tighten both securely.
8. Thread wires back along taillight conduit and install cable straps to original locations.
9. **1998 and Earlier Models;** Insert terminals into connector (under seat). Mate connector halves.
10. **1999 and later Models;** Insert terminal into 2-pin connectors. Install connectors to circuit board (inside rear tail lamp).
11. Connect battery cables, positive cable first.

WARNING

Connect positive (+) battery cable first. If positive (+) cable should contact ground with negative (-) cable connected, the resulting sparks can cause a battery explosion, which could result in death or serious injury. (00068a)

12. Install seat, if removed.

WARNING

After installing seat, pull upward on seat to be sure it is locked in position. While riding, a loose seat can shift causing loss of control, which could result in death or serious injury. (00070b)

13. Check turn signals for proper operation.

WARNING

Be sure headlamp, tail and stop lamp and turn signals are operating properly before riding. Poor visibility of rider to other motorists can result in death or serious injury. (00478b)

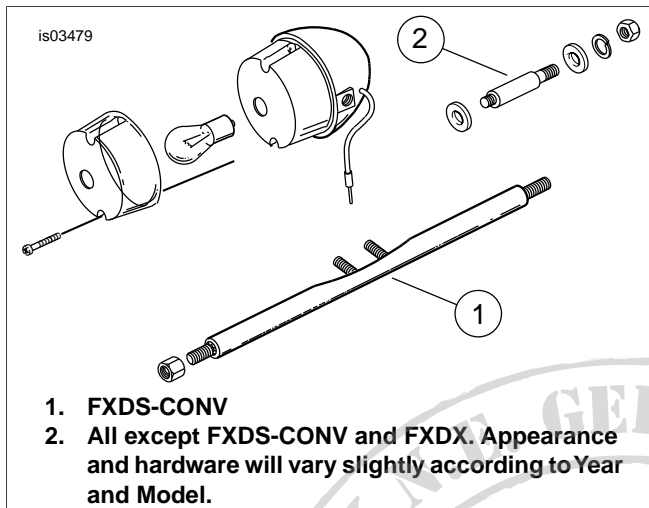

Figure 5. All (Typical Tube-Style Supports)

FXDS-CONV, 1999 and Later FXDX, FXR2, 3 and 4 and All Other Models with Tube-Style Supports

NOTES

Prior to removing turn signal wires, carefully note routing. In particular pay close attention to the locations of cable straps which must be replaced.

When removing turn signal wiring, refer to appendix in applicable Service manual covering detailed procedures for Amp Multilock Electrical Connections.

1. Remove Turn Signal Wiring according to the following:
1998 and Earlier Models; Remove seat and disconnect connector halves at connector [7]. Following instructions in applicable Service Manual, remove left and right turn signal wiring from connectors.
1999 and Later Models; Remove left and right turn signal 2-pin connectors from circuit board (inside rear rail lamp). Following instructions in applicable Service Manual, remove left and right turn signal wiring from connectors.

NOTE

To aid in installing new turn signal wires, attach a thin wire to terminals on old turn signal wires before pulling old wires out of support tube. This thin wire can be used to guide new wires back through support tube.

2. Pull wiring through conduit and remove from housing.
3. See Figure 5. Remove lamp housing from turn signal support. Save hardware. Discard lamp.
4. Lay old turn signal lamp housing next to replacement housing from kit and cut new wires to length.

5. The new lamp housing must be modified slightly prior to mounting. Performing the following:
 - a. See Figure 6. Insert a flat-bladed screwdriver into recessed slot on turn signal lens. Gently twist until lens pops out.
 - b. Remove bulb by gently pushing and turning.
 - c. Remove reflector by inserting a small screwdriver between reflector and rubber grommet surrounding reflector. Slowly and gently pry reflector from lamp housing. Note orientation of reflector in the housing.
 - d. Push wire grommet (surrounding wires) into the lamp and remove the reflector with the wires.
 - e. See Figure 7. Install rubber plug into the hole vacated by the wires.
 - f. Carefully remove the plastic conduit from the wires.
6. See Figure 7. Install lamp housing onto the support as shown.

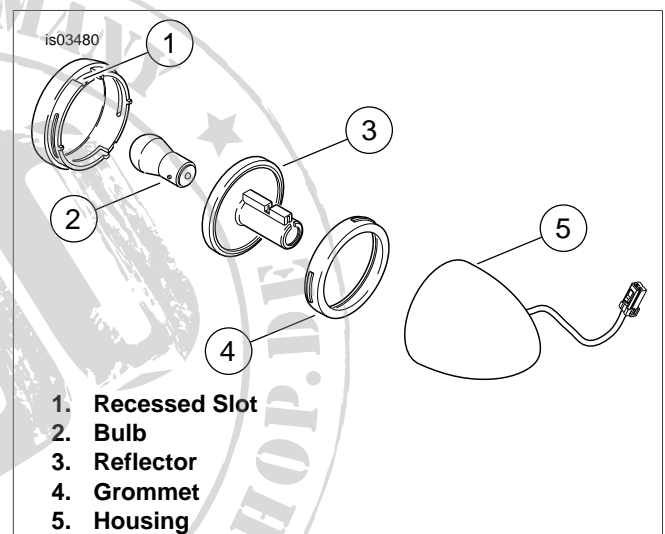
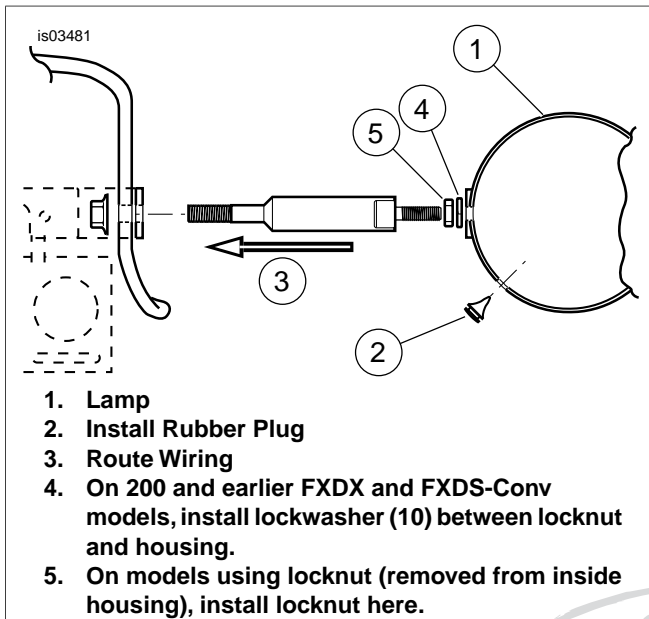

Figure 6. Lamp Assembly



1. Lamp
2. Install Rubber Plug
3. Route Wiring
4. On 200 and earlier FXDX and FXDS-Conv models, install lockwasher (10) between locknut and housing.
5. On models using locknut (removed from inside housing), install locknut here.

Figure 7. Typical Housing Mounting and Wire Routing for Models equipped with Tube-Style Supports

NOTES

In cases in which the locknut was installed originally to the support from inside the lamp, install the locknut to the support outside of the lamp.

On 2000 and earlier FXDX and FXDS-Convertible models, install lockwasher (item 10) between the lamp housing and the chrome locknut.

7. Align the housing and depending on hardware:
 - a. Tighten the housing against the support.
 - b. Tighten locknut against the housing.
8. Route wiring from lamp assembly through support and into fender.

NOTE

When performing the next Step, use rubbing alcohol to lubricate the rubber grommet and aid installation.

9. Install reflector and grommet to housing.
10. Install bulb into reflector, then install lens.
11. Thread wires back through conduit.

NOTES

When performing the next step, use Terminal P/N 72039-71 for 1995 and earlier models. Use Terminal P/N 73191-96 for 1996 and later models.

When performing the next step on 1994 and earlier models, terminate the ground wire (Black) using ring terminal P/N 9858 and secure to ground screw or other suitable location. For power wire, use terminal as described in previous note and route following same path as original.

12. Following instructions in Service Manual covering Amp Multilock Electrical Connectors, crimp new terminals onto wires from kit.
13. Route wires along bottom of fender following same path as original wiring and install cable straps to original locations
14. **1998 and Earlier Models;** Insert terminals into connector [7] (under seat). Mate connector halves.
1999 and later Models; Insert terminals into 2-pin connectors. Install connectors to circuit board (inside rear tail lamp).
15. Connect battery cables, positive cable first.

⚠ WARNING

Connect positive (+) battery cable first. If positive (+) cable should contact ground with negative (-) cable connected, the resulting sparks can cause a battery explosion, which could result in death or serious injury. (00068a)

16. Install seat, if removed.

⚠ WARNING

After installing seat, pull upward on seat to be sure it is locked in position. While riding, a loose seat can shift causing loss of control, which could result in death or serious injury. (00070b)

17. Check turn signals for proper operation.

⚠ WARNING

Be sure headlamp, tail and stop lamp and turn signals are operating properly before riding. Poor visibility of rider to other motorists can result in death or serious injury. (00478b)

SERVICE PARTS

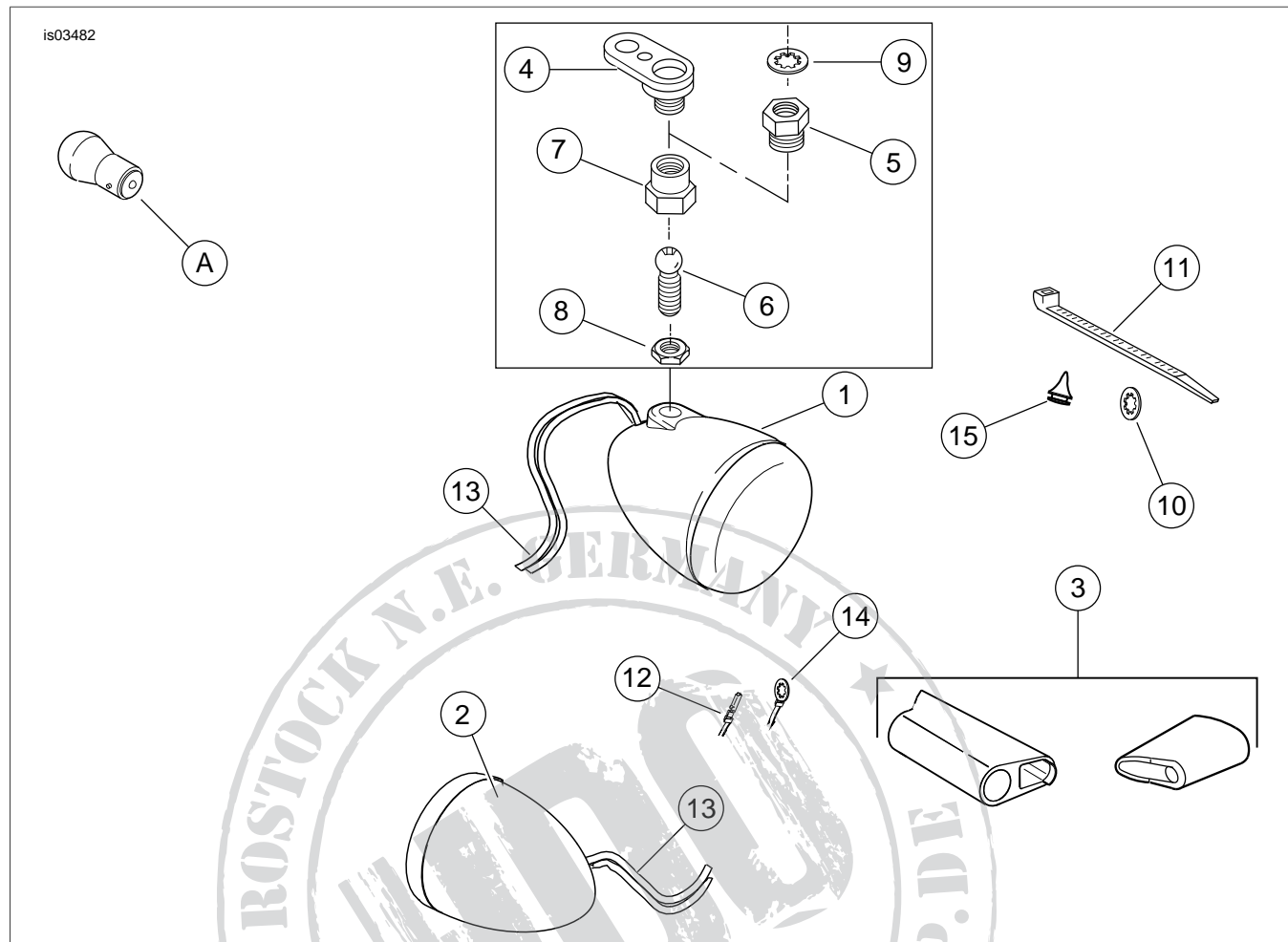

Figure 8. Service Parts: Bullet Style Turn Signal Kit

Table 2. Service Parts Tables

Kit 68005-99 (Domestic)			Kit 68007-99 (Domestic)		
Item	Description (Quantity)	Part Number	Item	Description (Quantity)	Part Number
1	Lamp assembly (front) (2)	69094-00	1	Lamp assembly (front) (2)	69094-00
2	Lamp assembly (rear) (2)	69092-00	2	Lamp assembly (rear) (2)	69092-00
3	Standoff, directional (2)	not sold separately	3	Standoff, directional (2)	not sold separately
	Swivel Kit (includes parts 4-9)	68185-00		Swivel Kit (includes parts 4-9)	68185-00
4	• Ball receptacle (1)	not sold separately	4	• Ball receptacle (1)	not sold separately
5	• Retainer, mirror (1)	not sold separately	5	• Retainer, mirror (1)	not sold separately
6	• Ball stud (2)	not sold separately	6	• Ball stud (2)	not sold separately
7	• Clamp, ball stud (2)	not sold separately	7	• Clamp, ball stud (2)	not sold separately
8	• Nut, jam (2)	7912	8	• Nut, jam (2)	7912
9	• Lockwasher (2)	7127	9	• Lockwasher (2)	7127
10	Lockwasher 5/16 (2)	94081-90T	10	Lockwasher 5/16 (2)	94081-90T
11	Cable strap (10)	10065	11	Cable strap (10)	10065
12	Pin terminal (10)	72039-71A	12	Pin terminal (10)	72039-71A
13	Recept, contact 20-16 gauge (10)	73191-96	13	Recept, contact 20-16 gauge (10)	73191-96
14	Ring terminal (4)	9858	14	Ring terminal (4)	9858

Table 2. Service Parts Tables

Kit 68005-99 (Domestic)			Kit 68007-99 (Domestic)		
Item	Description (Quantity)	Part Number	Item	Description (Quantity)	Part Number
15	Plug (2)	58758-93	15	Plug (2)	58758-93
			16	V-seam, split tube (2) (not shown)	59959-86
A	Replacement Bulbs: Kit 68005-99 and 68007-99 use: (Front) 68168-89; (Rear) 68572-64B				

Table 2. Service Parts Tables

Kit 68637-99 (HDI)			Kit 68690-99 (HDI)		
Item	Description (Quantity)	Part Number	Item	Description (Quantity)	Part Number
1	Lamp assembly (front) (2)	69095-00	1	Lamp assembly (front) (2)	69095-00
2	Lamp assembly (rear) (2)	69093-00	2	Lamp assembly (rear) (2)	69093-00
3	Standoff, directional (2)	not sold separately	3	Standoff, directional (2)	not sold separately
	Swivel Kit (includes parts 4-9)	68185-00		Swivel Kit (includes parts 4-9)	68185-00
4	• Ball receptacle (1)	not sold separately	4	• Ball receptacle (1)	not sold separately
5	• Retainer, mirror (1)	not sold separately	5	• Retainer, mirror (1)	not sold separately
6	• Ball stud (2)	not sold separately	6	• Ball stud (2)	not sold separately
7	• Clamp, ball stud (2)	not sold separately	7	• Clamp, ball stud (2)	not sold separately
8	• Nut, jam (2)	7912	8	• Nut, jam (2)	7912
9	• Lockwasher (2)	7127	9	• Lockwasher (2)	7127
10	Lockwasher 5/16 (2)	94081-90T	10	Lockwasher 5/16 (2)	94081-90T
11	Cable strap (10)	10065	11	Cable strap (10)	10065
12	Pin terminal (10)	72039-71A	12	Pin terminal (10)	72039-71A
13	Recept, contact 20-16 gauge (10)	73191-96	13	Recept, contact 20-16 gauge (10)	73191-96
14	Ring terminal (4)	9858	14	Ring terminal (4)	9858
15	Plug (2)	58758-93	15	Plug (2)	58758-93
			16	V-seam, split tube (2) (not shown)	59959-86
A	Replacement Bulbs: Kit 68637-99 and 68690-99 use: (Front and Rear) 68168-89				