



INSTRUCTIONS

-J05849

2013-06-14

AIR WING SADDLEBAG LID RAIL LIGHTS

GENERAL

Kit Numbers

68000114, 68000115

Models

For model fitment information, see the P&A retail catalog or the Parts and Accessories section of www.harley-davidson.com (English only).

Additional Parts Required

Prior or concurrent installation of Air Wing Saddlebag Rails is required for proper installation of this kit on this model motorcycle.

▲ WARNING

The rider's safety depends upon the correct installation of this kit. If the procedure is not within your capabilities or you do not have the correct tools, have a Harley-Davidson dealer perform the installation. Improper installation of this kit could result in death or serious injury. (00308a)

NOTE

This instruction sheet refers to service manual information. A service manual for this year/model motorcycle is available from a Harley-Davidson dealer.

Electrical Overload

NOTICE

It is possible to overload your vehicle's charging system by adding too many electrical accessories. If the combined electrical accessories operating at any one time consume more electrical current than the vehicle's charging system can produce, the electrical consumption can discharge the battery and cause damage to the vehicle's electrical system. See an authorized Harley-Davidson dealer for advice about the amount of current consumed by additional electrical accessories or for necessary wiring changes. (00211c)

▲ WARNING

When installing any electrical accessory, be certain not to exceed the maximum amperage rating of the fuse or circuit breaker protecting the affected circuit being modified. Exceeding the maximum amperage can lead to electrical failures, which could result in death or serious injury. (00310a)

This Air Wing Saddlebag Lid Rail Lights kit requires up to 50 mA additional current from the electrical system.

Kit Contents

See Figure 3 and Table 1.

INSTALLATION

1. **If saddlebag rails have not yet been installed:** Perform the Air Wing Saddlebag Rail installation up to the point of final assembly of the rails to the saddlebag lids. **If saddlebag rails are already installed:** Open one saddlebag and remove all loose contents. See the service manual. Remove the saddlebag. From the underside of the saddlebag lid, remove the fasteners retaining the saddlebag rail to the lid. Note fastener position and save all components for installation.
2. **ALL installations:** See Figure 3. Obtain a saddlebag rail light assembly (1) from the kit.
3. Insert the light wires through the hole (B) in the side of the saddlebag rail (A) mounting post, and out through the bottom of the post.
4. Install the light to the underside of the saddlebag rail rear cross bar with two screws (4) from the kit. Tighten the screws securely.
5. Insert the light wires through the left rear saddlebag rail mounting pad (C) and the left rear hole (H) in the saddlebag lid (G). Assemble the saddlebag rail to the lid per the instructions in the Air Wing Saddlebag Rail Kit, feeding the wires through the left rear saddlebag rail nylon washer (D), plain washer (E) and the hex head hollow screw (F). Tighten the two **Phillips head screws** to 3.1–3.5 N·m (27–31 **in-lbs**). Tighten the hex head **hollow screw** to 3.4–5.6 N·m (30–50 **in-lbs**).

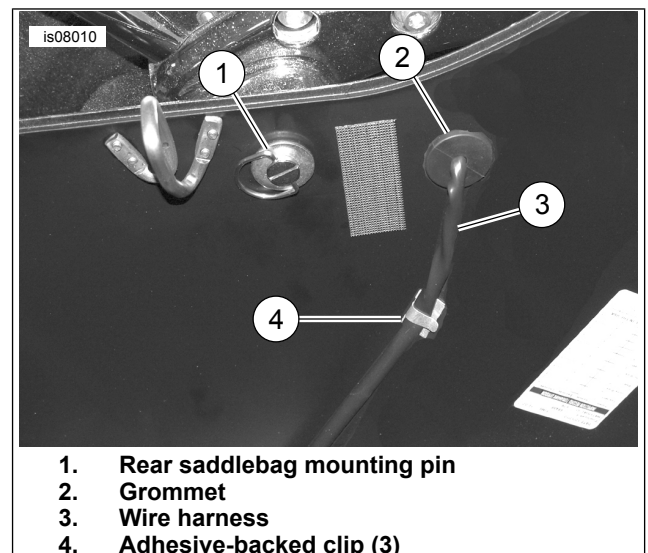

Figure 1. Wire Routing Inside Saddlebag

6. If equipped, remove the saddlebag liner. See Figure 1. Measure approximately 70 mm (2.75 in) on center forward from the rear saddlebag mounting pin location, and affix a strip of masking tape to the **inside** wall of the saddlebag at that location. Mark the location on the tape with a center punch, then:
 - a. drill a 2 mm (1/16 in) diameter pilot hole through the saddlebag wall.
 - b. Enlarge the hole using a 10 mm (3/8 in) drill bit.
7. Remove the tape. Lightly sand to remove burrs and sharp edges. Clean the inside and outside saddlebag surfaces of tape and drilling residue with a mixture of 50-70% isopropyl alcohol and 30-50% distilled water. Allow to dry thoroughly.
8. Install one of the rubber grommets (2) in the hole.
9. Attach the light wires to the inside of the saddlebag around the bottom with adhesive backed clips (4) and route the wires up the inner wall of the saddlebag and out through the grommet.
10. Repeat for the remaining saddlebag rail light assembly and saddlebag.
11. See the service manual. Install the saddlebags.

WIRING

1. See the service manual. Remove the seat.
2. See Figure 3. Obtain three socket terminals (2) and one socket housings (3) from the kit. See the service manual for the instructions to crimp the terminals onto the saddlebag rail light wires. Apply dielectric grease to terminals.
3. Insert the wires and terminals from one saddlebag rail light into one of the socket housings: Repeat for the remaining wires and socket housing.
 - a. Insert the **blue** wire into cavity 1.
 - b. Insert the **red/yellow** wire into cavity 2.
 - c. Insert the **black** wire into cavity 3.
4. Obtain the adapter harness (7) from the kit. See Figure 2. Locate the six-way rear lighting harness connector [7] in the area under the seat.

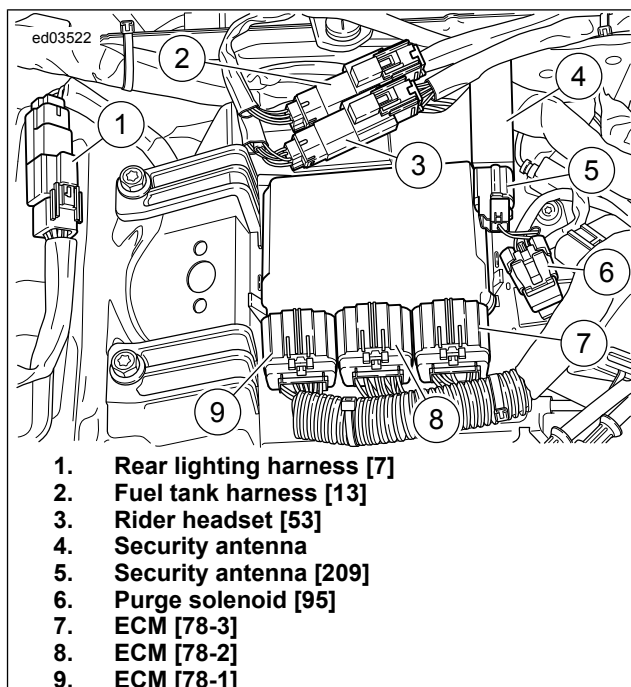

Figure 2. Under Seat: FLHT

5. Connect the saddlebag rail light adapter harness to the vehicle rear lighting harness connector [7]. Connect the left and right saddlebag rail light wires to the adapter harness. Organize the wires neatly alongside the frame rails and secure to the frame with cable straps.
6. Turn the ignition key switch to IGNITION, but do not start the motorcycle. Test the saddlebag rail lights **and** the motorcycle lamps for proper operation:
 - a. With the ignition switch on, the LEDs in each saddlebag rail light should be illuminated, along with the vehicle tail lamp(s).
 - b. When either the brake hand lever of foot pedal are activated, the LEDs in each saddlebag rail light should noticeably brighten, along with the vehicle stop lamp(s).
 - c. When either turn signal switch is activated, the LEDs in each saddlebag rail light should remain lit steadily, and not flash.
 - d. Turn the ignition key switch to OFF. Both saddlebag rail lights should turn off immediately, along with the vehicle tail lamp(s).

▲ WARNING

After installing seat, pull upward on seat to be sure it is locked in position. While riding, a loose seat can shift causing loss of control, which could result in death or serious injury. (00070b)

7. See the service manual. Install the seat.

SERVICE PARTS

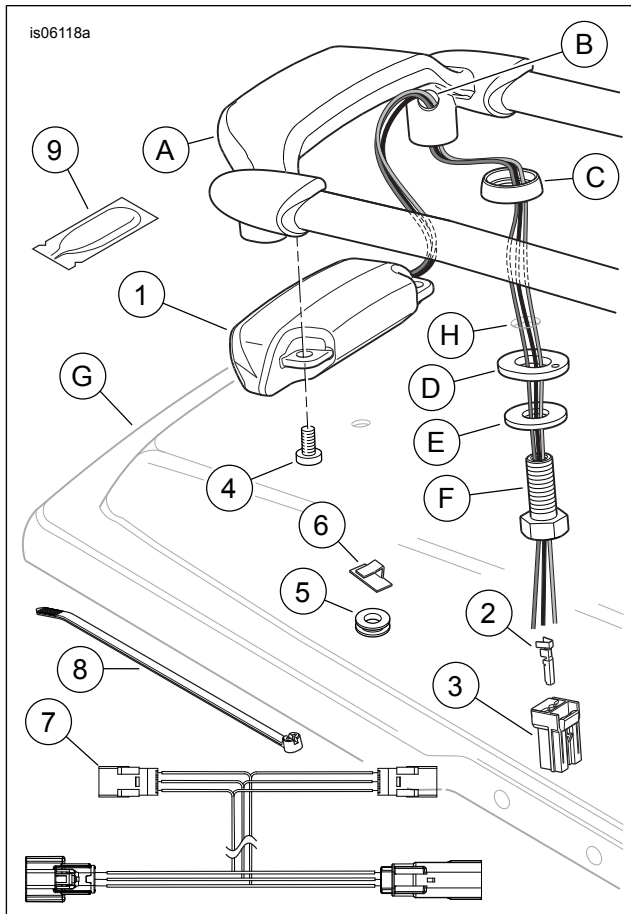

Figure 3. Service Parts, Air Wing Saddlebag Lid Rail Light Kits

Table 1. Service Parts

Item	Description (Quantity)	Part Number
1	Light assembly, smoked lens (2, for Kit 68000114) (includes Items 2 and 3)	68106-10
	Light assembly, red lens (2, for Kit 68000115) (includes Items 2 and 3)	68488-10
2	• Socket terminal (3)	73191-96
3	• Socket housing, three-way	73153-96BK
4	Screw, socket head (4), #8-32 x 8 mm (0.31 in) long	Not sold separately
5	Grommet (2)	11410
6	Clip, adhesive-backed (12)	10102
7	Wire harness	69200789
8	Cable strap (6)	10006
9	Dielectric grease packet	76001-04
Items mentioned in text, but not included in kit.		
A	Air Wing saddlebag rail	
B	Hole in side of saddlebag rail mounting post	
C	Left rear saddlebag rail mounting pad	
D	Left rear saddlebag rail nylon washer	
E	Left rear saddlebag rail plain washer	
F	Hex head hollow screw	
G	Saddlebag lid	