



INSTRUCTIONS

-J05090

REV. 2010-11-13

TOUR-PAK WRAP-AROUND LED LIGHT KITS

GENERAL

Kit Numbers

67931-11, 67932-11

Models

For model fitment information, see the P&A retail catalog or the Parts and Accessories section of www.harley-davidson.com (English only).

Tools and Supplies Required

Silicone sealant, a drill and various small bits will be needed to install this kit.

Electrical Contact Lube (H-D Part No. 99861-02) or equivalent is required for the proper installation of this kit. This item is available from a Harley-Davidson dealer.

⚠ WARNING

The rider's safety depends upon the correct installation of this kit. Use the appropriate service manual procedures. If the procedure is not within your capabilities or you do not have the correct tools, have a Harley-Davidson dealer perform the installation. Improper installation of this kit could result in death or serious injury. (00333a)

NOTE

This instruction sheet refers to service manual information. A service manual for this year/model motorcycle is required for this installation and is available from a Harley-Davidson dealer.

Electrical Overload

NOTICE

It is possible to overload your vehicle's charging system by adding too many electrical accessories. If the combined electrical accessories operating at any one time consume more electrical current than the vehicle's charging system can produce, the electrical consumption can discharge the battery and cause damage to the vehicle's electrical system. See an authorized Harley-Davidson dealer for advice about the amount of current consumed by additional electrical accessories or for necessary wiring changes. (00211c)

⚠ WARNING

When installing any electrical accessory, be certain not to exceed the maximum amperage rating of the fuse or circuit breaker protecting the affected circuit being modified. Exceeding the maximum amperage can lead to electrical failures, which could result in death or serious injury. (00310a)

This Light Kit requires up to **230 mA** additional current from the electrical system.

Kit Contents

See Figure 3 and Table 1.

INSTALLATION

Preparation

Models with main fuse:

⚠ WARNING

To prevent accidental vehicle start-up, which could cause death or serious injury, remove main fuse before proceeding. (00251b)

1. Refer to the service manual and follow the instructions given to remove the main fuse.

Models with main circuit breaker:

⚠ WARNING

To prevent accidental vehicle start-up, which could cause death or serious injury, disconnect negative (-) battery cable before proceeding. (00048a)

1. Refer to the service manual and follow the instructions given to remove the seat and disconnect the negative (black) battery cable from the negative (-) battery terminal. Retain all seat mounting hardware.

NOTE

When working on the Tour-Pak® with the lid open, brace or tie the lid securely in the open position to prevent head, hand or finger injury, or scratching of the Tour-Pak lid finish.

2. Open the Tour-Pak lid and, if necessary, remove all items from inside the Tour-Pak.

Models with molded liner: Open the pouch and remove the acorn nuts with flat washers. Remove the pouch and liner.

3. Remove the mast from the antenna, and set aside for later installation.

Remove all of the antenna components from the rear wall of the Tour-Pak, and set aside for later discard or installation.

4. Remove all nuts holding the existing light from the back wall of the Tour-Pak.

5. Remove the existing Tour-Pak light by cutting away the caulking from inside of the Tour-Pak.

6. After light is removed clean any remaining caulk from opening in Tour-Pak.

Installation

- Position the template (19) from the kit across the rear of the Tour-Pak, aligning the template around the hinge on the left side and the latch on the right. Tape the template securely to the Tour-Pak.
- Drill 1/16 inch (1.5 mm) diameter pilot holes through the template and Tour-Pak at fourteen marked locations.
- Drill holes at each pilot location as indicated on the template:
 - **ALL installations:**
 - One 0.437 in. (11.0 mm) diameter hole near the center.
 - One 0.312 in. (7.9 mm) diameter hole at the left rear.
 - 0.531 in. (13.5 mm) holes in the remaining ten locations.
- Remove the template. Smooth off any rough edges around the holes, and clean up any drilling debris and tape residue from the Tour-Pak.
- See Figure 3. Apply a small amount of silicone sealant around the base of the seven threaded studs (A) on the back of the LED Wrap-Around Light assembly (1) to prevent water leakage into the Tour-Pak.

NOTE

The LED Wrap-Around Light assembly mounts to the Tour-Pak with the antenna holes (B, C) facing UP.

- Mark the two-wire conduits (D) with their source (left or right lamp), close to the terminal ends. Make sure the conduits are retained in the grooved ribs inside the light assembly.
Insert the wires from the three lamps through the 0.437 in. (11.0 mm) diameter hole near the center. Pull the wires through the hole while positioning the light assembly to the Tour-Pak.

NOTE

If the motorcycle is equipped with an AM/FM radio antenna mounted on the Tour-Pak: Install backing plates inside Tour-Pak to cover the large holes in the Tour-Pak. Secure by positioning over stud from light and flange nut.

- Fasten the light assembly with the seven flange nuts (6), but do not fully tighten at this time.
- From the inside of the Tour-Pak, use the four TORX® pan head screws (7) and washers (8) to fasten the light assembly at the sides. Tighten securely.
- Alternately tighten the flange nuts securely.

Wiring

- Get the eight-way Molex pin housing (9) from the kit. See Figure 1. Follow the instructions in the service manual to

insert the light assembly wires and pin terminals into the correct cavities of the housing:

- Violet** wire from **right** auxiliary tail lamp to cavity 1.
- Violet** wire from **center** auxiliary tail lamp to cavity 2.
- Blue** wire from **center** auxiliary stop lamp to cavity 3.
- Violet** wire from **left** auxiliary tail lamp to cavity 4.
- Black** wire from **left** lamp ground to cavity 5.
- Black** wire from **center** lamp ground to cavity 6.
- Seal plug** (10) to cavity 7.
- Black** wire from **right** lamp ground to cavity 8.

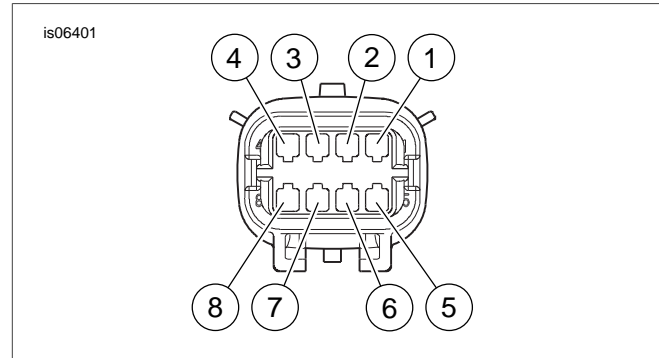

Figure 1. Molex Eight-Way Pin Housing 72478-07BK (Wire-End View): Cavity Identification

- Get the adapter harness with module (11) from the kit. Plug the eight-way socket housing from the adapter harness into the Molex pin housing from the LED Wrap-Around Light assembly.
- Route the adapter harness out through the grommet at the lower front corner of the Tour-Pak, and toward the rear lighting harness connector [7] on the vehicle. Position the control module on the floor of the Tour-Pak between the steel plate and the back wall.

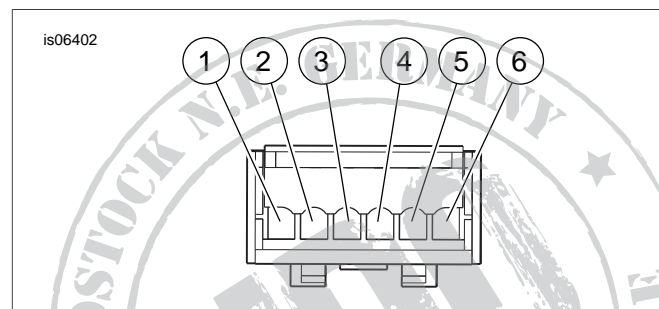

Figure 2. AMP Six-Way Pin Housing 73106-96BK (Wire-End View): Cavity Identification

- Get the six-way AMP pin housing (12) from the kit. See Figure 2. Follow the instructions in the service manual to insert the adapter harness wires and pin terminals into the correct cavities of the housing:

Amp Six-Way Pin Housing Cavity Identification

- a. BN cavity 1
- b. O/W cavity 2
- c. V cavity 3
- d. BK cavity 4
- e. Yellow cavity 5

NOTE

For vehicles with Light Conversion Kit (69461-06B) installed: The Y-harness (13) must be installed between the main harness and the Light Conversion Kit harness. Disconnect the Light Conversion Kit harness from the main harness connector [7A], then connect the Y-harness (13) to the main harness [7A] and the Light Conversion Kit harness connector.

5. Get the Y-harness (13) from the kit. Unplug the halves of the vehicle rear lighting harness connector [7], and install the Y-harness between the main harness connector [7A] and rear lighting harness connector [7B].
6. Connect the adapter harness to the Y-harness.

Antenna Installation

1. If the motorcycle is equipped with an AM/FM radio antenna mounted on the Tour-Pak:
 - a. Insert the antenna adapter (14) into the cavity (B) at the top left of the lamp bezel (2), with the small threaded hole forward.
 - b. Shield the threads of the antenna plug assembly (16) with a strip of light cardboard and with pliers around the cardboard strip, thread it into the hole in the antenna adapter.
 - c. Install the washer (I) and antenna ground ring terminal and a **new** hex nut (17) onto the stud, and tighten securely.
 - d. Install the AM/FM antenna mast onto the adapter.
 - e. Insert the antenna adapter (E) into the cavity (C) at the top right of the lamp bezel (2), with the small threaded hole forward.
 - f. Shield the threads of the antenna terminal stud (F) with strip of light cardboard. Insert the stud through the large hole in the Tour-Pak and, with pliers around the cardboard strip, thread it into the hole in the antenna adapter.
 - g. Install the flat washer (G), antenna ground ring terminal and hex nut (H) onto the stud, and tighten securely.
 - h. Install the CB antenna mast onto the adapter.

2. Check the AM/FM and CB radio for proper operation.

Check Lamp Function

NOTE

Verify that the ignition key switch is in the OFF position **before** installing the main fuse or attaching the negative battery cable.

1. **Models with main fuse:** Refer to the service manual and follow the instructions given to install the main fuse.

Models with main circuit breaker: Refer to the service manual and follow the instructions given to attach the negative battery cable.

Apply a light coat of Harley-Davidson electrical contact lubricant (H-D Part No. 99861-02), petroleum jelly or corrosion retardant material to the negative battery terminal.

2. Check for proper lamp function:
 - With ignition key switch ON, All three lamp sections are illuminated.
 - With brake lever or brake pedal actuation, the CENTER section will brighten.
 - With left or right turn signal actuation, the end sections will flash.

⚠ WARNING

After installing seat, pull upward on seat to be sure it is locked in position. While riding, a loose seat can shift causing loss of control, which could result in death or serious injury. (00070b)

3. Refer to the service manual, and follow instructions to install the seat.
4. Install the rubber mat or molded liner. Install the pouch inside the Tour-Pak using the two acorn nuts with flat washers previously removed.



SERVICE PARTS

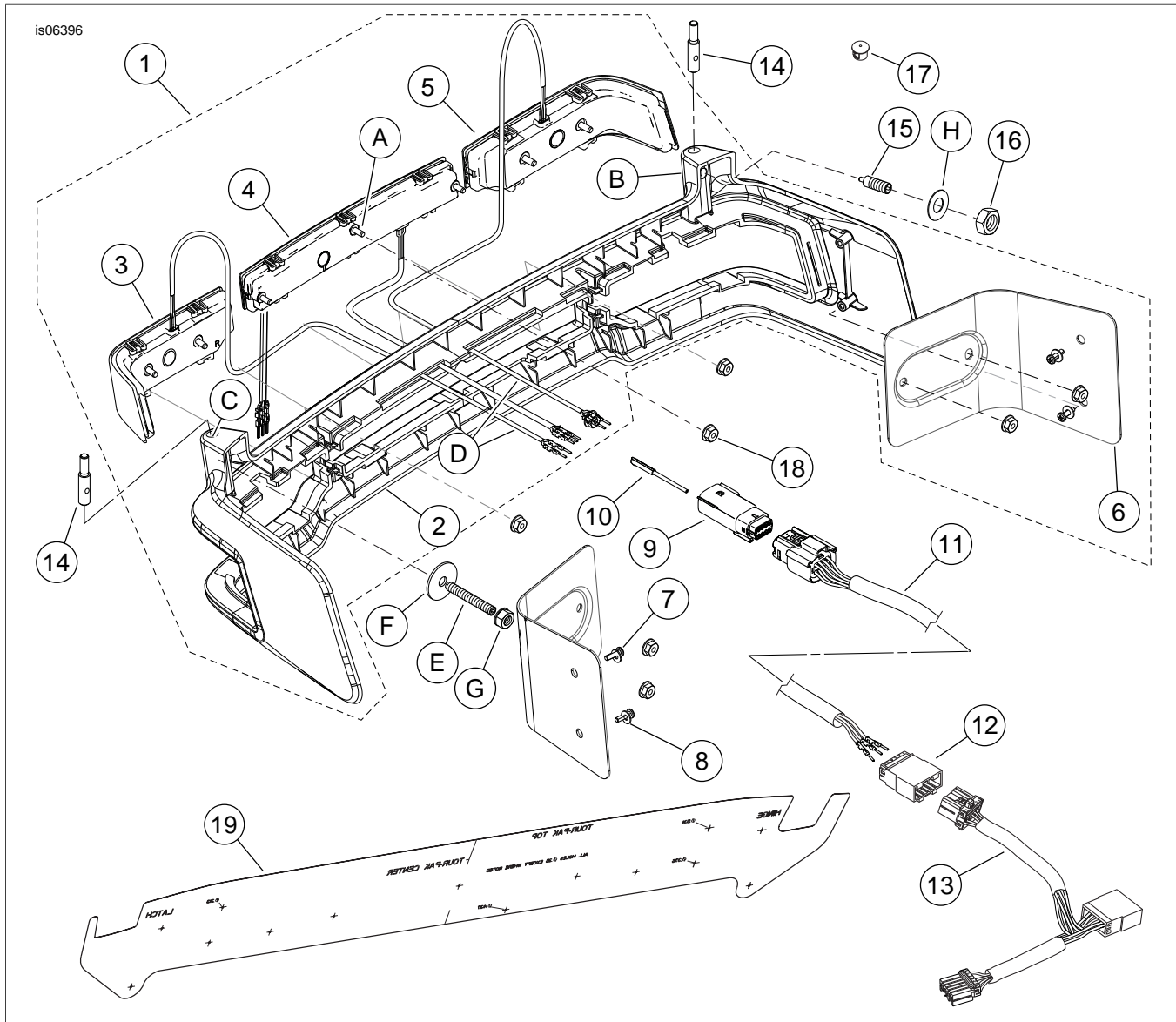

Figure 3. Service Parts, Tour-Pak Wrap-Around LED Light Kits



SERVICE PARTS

Table 1. Service Parts Table

Kit	Item	Description (Quantity)	Part Number
Kit 67853-10 Red Lens	1	LED Wrap-Around Light assembly (includes items 2 through 6)	Not sold separately
	2	• Bezel, LED Wrap-Around Light	67937-11DH
	3	• LED light assembly, red lens (right)	67862-10
	4	• LED light assembly, red lens (center)	73402-10
	5	• LED light assembly, red lens (left)	69901-10
	6	• Backing plate (2)	67945-11
Kit 67914-10 Smoked Lens	1	LED Wrap-Around Light assembly (includes items 2 through 6)	Not sold separately
	2	• Bezel, LED Wrap-Around Light	67937-11
	3	• LED light assembly, smoked lens (right)	67860-10
	4	• LED light assembly, smoked lens (center)	69908-10
	5	• LED light assembly, smoked lens (left)	69900-10
	6	• Backing plate (2)	67945-11
Parts common to BOTH kits	7	Screw, pan head TORX, #6 (4)	3597
	8	Washer (4)	6029
	9	Pin housing, eight-way, Molex	72478-07BK
	10	Seal plug	72473-07
	11	Module harness	69911-11
	12	Pin housing, six-way, AMP	73106-96BK
	13	Y-harness	Not sold separately
	14	Antenna adapter, AM/FM (2)	8230
	15	Antenna plug assembly	76258-86
	16	Hex jam nut	76259-86
	17	Plug (2)	90493-83
	18	Flange nut (7)	7878
	19	Drilling template	Not Sold Separately
Items mentioned in text, but not included in kit:			
	A	Threaded studs (7) on back of light assembly	
	B	AM/FM antenna cavity	
	C	CB antenna cavity	
	D	Two-wire conduits (2) from left or right lamp	

