



INSTRUCTIONS

-J05243

2011-08-18

XL1200C TURN SIGNAL RELOCATION KIT

GENERAL

Kit Numbers

67800071, 67800077

Models

For model fitment information, see the P&A retail catalog or the Parts and Accessories section of www.harley-davidson.com (English only).

Additional Parts Required

This kit is needed in order to complete the installation of a detachable saddlebag kit on specific model motorcycles. See the P&A retail catalog or the Parts and Accessories section of www.harley-davidson.com (English only) for available saddlebag kits, model fitment information and additional part requirements.

NOTE

This kit may be installed without saddlebags, but this will result in open holes in the fender support covers. The following hole plugs are available from a Harley-Davidson dealer:

- Part No. 68446-00, for 8.7 mm (0.344 in) diameter holes
- Part No. 6989, for 10.2 mm (0.400 in) diameter holes

Tools and Supplies Required

A Terminal Pick (Snap-On® TT600-3 or equivalent) and Amp Multi-Lock Crimper (HD-41609) will aid in the installation of this kit.

Electrical Contact Lube (Part No. 99861-02) or equivalent is required for the proper installation of this kit. This item is available from a Harley-Davidson dealer.

⚠ WARNING

The rider's safety depends upon the correct installation of this kit. Use the appropriate service manual procedures. If the procedure is not within your capabilities or you do not have the correct tools, have a Harley-Davidson dealer perform the installation. Improper installation of this kit could result in death or serious injury. (00333a)

NOTE

This instruction sheet refers to service manual information. A service manual for this year/model motorcycle is required for this installation and is available from a Harley-Davidson dealer.

Kit Contents

See Figure 3 and Table 1.

PREPARATION

NOTE

For vehicles equipped with security siren:

- Verify that the Hands-Free Fob is present.
- Turn the ignition key switch to IGNITION.

1. Remove the seat per service manual instructions. Retain all seat mounting hardware.

⚠ WARNING

To prevent accidental vehicle start-up, which could cause death or serious injury, remove main fuse before proceeding. (00251b)

2. Refer to the service manual and follow the instructions to remove the main fuse.

INSTALLATION

Electrical Disconnection

NOTE

- Label the vehicle-side right and left turn signal connector halves before disconnecting.
- Electrical connectors are identified in the service manual by the numbers and letters within brackets.

1. Remove the cable strap and unplug the two-way turn signal connectors [18] and [19] in the area under the seat.

NOTE

*Make note of the wire colors and cavity locations before removing the terminals from the socket housings **on the lamp side of the harness connections.***

2. See service manual and remove the wires and socket terminals from turn signal socket housings [18B] and [19B]. Set the socket housings aside for later installation.

Turn Signal Lamp Wiring

⚠ WARNING

Block or jack vehicle under frame in a way that the vehicle will not fall over. Failure to properly block and/or raise the vehicle could result in death or serious injury. (00462c)



NOTICE

When lifting a motorcycle using a jack, be sure jack contacts both lower frame tubes where down tubes and lower frame tubes converge. Never lift by jacking on cross-members, oil pan, mounting brackets, components or housings. Failure to comply can cause serious damage resulting in the need to perform major repair work. (00586d)

1. Position and secure the motorcycle upright using a suitable lift or jack.
2. Remove the upper rear shock bolts and raise the motorcycle to access the fasteners and wiring under the rear fender.
3. Remove the two fender support cover screws and the fender support cover from one side of the motorcycle.
4. Remove the nuts from the turn signal screw inside fender, and remove the turn signal lamp and lamp support from the fender support. Free the wires fully from the vehicle.
5. If installing rigid saddlebags or docking points, refer to the installation of that kit when installing the fender support covers. If no rigid saddlebag kit or docking point kit is being installed, install the fender support cover and screws. Tighten the screws to 15–24 N·m (11–18 ft-lbs).
6. Repeat steps 2-4 for the opposite side of the motorcycle.
7. See Figure 1. Insert the blade of a small screwdriver into the slot at the bottom of the lens (2) of one turn signal lamp, and twist to unsnap the lens from the housing (1). Push the bulb (3) in and rotate counterclockwise to remove. Set the lens and bulb aside for later installation.
8. Insert a right-angle pick or a 3 mm (7/64 in) hex key into the bulb socket cavity, hooking into one of the two bulb retainer slots (17) in the cavity. Pull the reflector (5) free of the lamp housing. Separate the rubber gasket (4) from the reflector or housing.
9. Slide the bulb socket (6) and spring (7) from the reflector. Remove the blue wire (11) with button terminal from the bulb socket.

NOTE

The remaining violet wires are not used in this installation.

10. Remove the ground terminal and black wire (10) from the back of the reflector. Guide the protective tubing (13) with both wires out of the unthreaded hole (8) in the lamp housing, and discard.
11. Get two **new** terminated wires, one black and one blue from the kit.
12. Insert the **unterminated** ends of the wires, **from the inside**, through the **threaded** hole (9) in the lamp housing (1).
13. Slip the rubber gasket (4) over the terminated ends of the wires.

14. Insert the terminal of the **new** black wire (10) into the cavity in the rear of the reflector (5) until it clicks into place. Thread the **new** blue wire (11) through the center of the reflector and spring (7), and insert the button terminal into the slot and cavity in the reflector bulb socket (6).

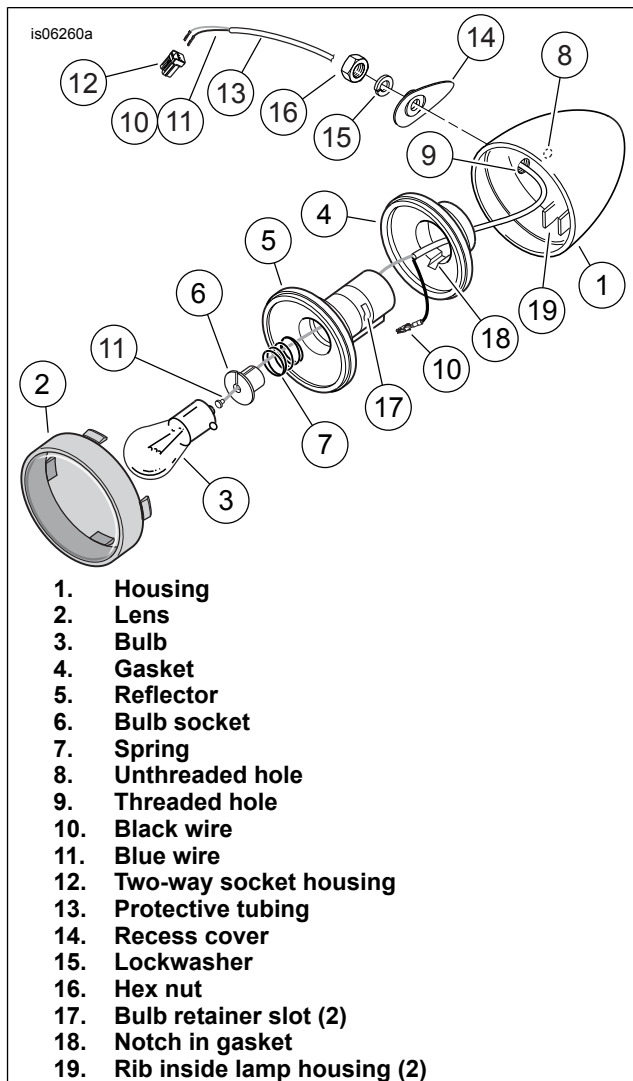

Figure 1. Turn Signal Lamp

15. Assemble the lamp as follows:

- a. Insert the spring and bulb socket back into the reflector.
- b. Seat the reflector assembly in the rubber gasket, aligning the ground terminal on the reflector with the notch (18) in the gasket.
- c. Install the reflector and gasket assembly, aligning the ground terminal on the reflector between the parallel ribs (19) inside the lamp housing and leaving about 50–100 mm (1–2 in) of wire **inside** the housing.
- d. Using the thumbs of both hands, apply even pressure around the outer edge of the reflector assembly until fully seated.
- e. Liberally apply electrical contact lubricant (H-D Part No. 99861-02) or equivalent to the contact in the reflector socket and at the base of the bulb. Push in the bulb and rotate clockwise to install.

- f. Install the lens to the lamp housing and gently apply thumb pressure until it snaps into place. Rotate the lens to position the slot at the bottom of the lamp when installed on the new light bar.
16. Repeat steps 6 through 14 for the remaining turn signal lamp.

Light Bar Assembly

NOTE

See Figure 3. When assembling the light bar (1) to the spacer (2) and relocation mount (3), the correct orientation is with the wire-exit holes (B) angled **toward** the downward bend as shown in View (D), **NOT** away from it.

1. Remove the protective caps from the two threaded studs (A) on the light bar assembly.
2. Install the spacer and angled relocation mount onto the studs as shown
3. Install washers (4) and acorn nuts (5) onto the studs, and tighten to 2.3–2.8 N·m (20–25 in-lbs).

Turn Signal Lamp Installation to Light Bar

NOTE

Be sure the recess cover, lockwasher and jam nut have been installed in the **exact** orientation and sequence shown **before** feeding the wiring through the light bar assembly.

1. See Figure 3. Loosely install a chrome jam nut (9) onto one of the threaded studs on the ends of the light bar. Place a lockwasher (8) onto the stud, against the jam nut. Place a chrome recess cover (7), in the orientation shown, onto the stud.

NOTE

If necessary, apply a light coat of liquid soap, window cleaner or all-purpose lubricant to the wire ends. Use a fish tape or mechanics' wire if needed to guide the wires through the bar.

2. Feed the **unterminated end** of **one** turn signal wire into the threaded stud. Guide the wire into the tube, and push the wire toward the closest hole (B). Pull the end of the wire out of the hole.
3. Repeat Step 2 for the remaining wire.
4. Continue pulling and pushing the wires until the turn signal lamp is approximately 100 mm (2 in) from the end of the light bar.
5. Pre-wind the wires by rotating the still unattached turn signal to the left (counter-clockwise) approximately two to three full turns. With the signal wires slightly twisted, pull the remaining wire through the bar until the lamp is touching the threaded stud at the light bar end.
6. Screw the lamp housing onto the stud.
 - a. Be careful that the wires are not twisted or damaged as the light bar and lamp are assembled.
 - b. Align the recess cover over the holes and recess in the lamp housing. The lockwasher will fit inside the hole in the recess cover.
 - c. Align the lamp housing so that the lens will be aimed rearward and parallel to the ground when the light bar is installed on the vehicle.
 - d. While holding the housing in position, hand tighten the jam nut against the lockwasher.

NOTE

If necessary, apply a light coat of liquid soap, window cleaner or all-purpose lubricant to the inside and outside of the protective tubing.

10. Slide a piece of the protective tubing over one set of lamp wires and into the opening in the light bar. Continue sliding the tubing over the wires until it reaches the threaded stud.
11. Mark the turn signal wire bundle either "left" or "right" as appropriate.
12. Repeat steps 9 through 11 for the remaining turn signal lamp.

Drill Wire Hole in Fender

1. Remove the license plate from the vehicle (if installed). Retain the plate and attaching hardware.
2. Remove the two #10-32 screws and washers holding the license plate bracket to the tail lamp base. Discard the screws but retain the washers and license plate bracket.

NOTE

Cover the tail lamp and chrome base with protective material to prevent scratching of the finish.

3. See Figure 2. Drill a hole for the turn signal wires in the rear fender as follows:
 - a. Place a piece of masking tape on the rear fender in the area above and to the left of the tail lamp base as shown.
 - b. Measure up approximately 13 mm (½ in) from the tail lamp section of the base and mark a line (1) on the tape. Mark a second line (2) approximately 13 mm (½ in) to the left of the license plate section of the tail lamp base. Where the lines cross, mark the hole position with a center punch.
 - c. Place a wooden block or similar protection between the rear tire and the underside of the fender at the drilling location. Make sure the tail lamp wire harness is below and clear of the hole location. Drill a 1/8 in (3 mm) pilot hole through the tape and fender, followed by a 7/16 in (11 mm) diameter hole (3).
 - d. Remove the wooden block, and the tape. Deburr the hole edges, and clean the fender of tape and drilling residue.
 - e. Protect the edges of the drilled hole with touch-up paint or clear nail polish to protect the exposed metal from corrosion.
 - f. Insert the grommet from the kit into the new hole in the fender.

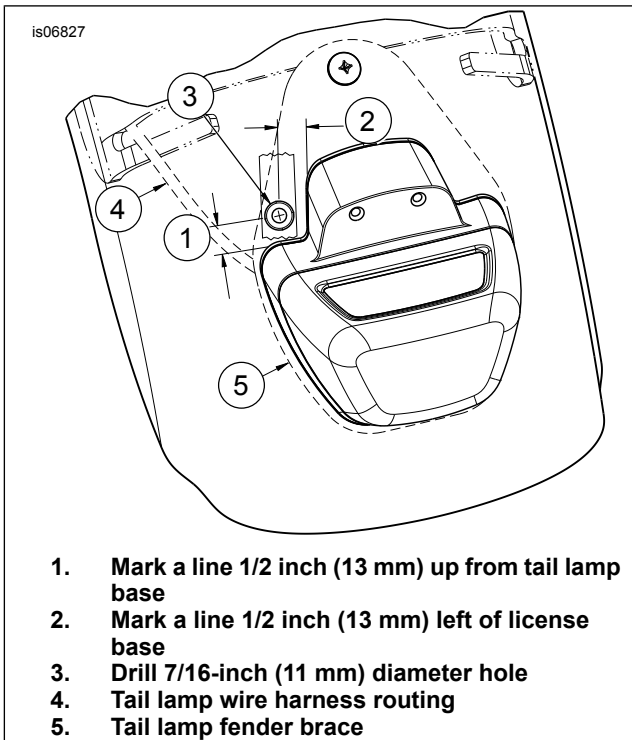

Figure 2. Wire Hole Location

Light Bar Installation to Vehicle

NOTE

Cover the rear fender with an H-D Service Cover or clean shop towel to prevent scratching the finish.

NOTE

- If necessary, apply a light coat of liquid soap, window cleaner or all-purpose lubricant to the grommet hole and protective tubing.
- Make sure the bundles retain their "left" or "right" identification after passing through the grommet.

1. See Figure 3. Bring the light bar assembly to the tail lamp area, with the relocation mount (3) oriented toward the rear and down as shown in View (D).
2. Feed the two turn signal wire bundles through the new grommet (10) in the fender.
3. With the wires pulled nearly all the way through the grommet, align the light bar assembly bracket to the two threaded holes in the tail lamp base. Align the license plate bracket removed earlier to the holes, and loosely install with the **new** screws (6) from the kit and the original washers (E).
4. Tuck the right-side turn signal wire bundle into the space between the light bar mount, acorn nuts and the top of the tail lamp base.

5. With the vehicle upright, level the light bar assembly parallel to the ground, and tighten the screws to 2.3–2.8 N·m (20–25 in-lbs).
6. Align the turn signal housings so that the lenses are aimed straight rearward for proper visibility. While holding the turn signal housings in position, tighten the hex nuts and lock washers against the housings (not the recess covers) to 11–14 N·m (96–120 in-lbs).

Turn Signal Wiring Connection to Vehicle

1. Route the turn signal wire bundles following the path of the tail lamp wiring through the left side channels, toward the front of the fender and out through the wire pass-through hole in the fender, to the area under the seat.
2. Route the turn signal wires and protective tubing over to the two-way turn signal connectors [18] and [19] on the vehicle harness. Allow an extra 50–100 mm (2–4 in) to easily make the connections, and cut the unterminated wires and tubing.
3. See Figure 3. Get four socket terminals (15) from the kit, and the two-way socket housings removed from the original wires.
4. Follow the instructions in the service manual to crimp the terminals onto the turn signal wires. Refer to the notes made during the removal steps, and insert the turn signal socket terminals into the correct cavities of the socket housings.
5. Connect the socket housings to the pin housings [18] and [19] on the vehicle harness. Tuck the connectors and wiring into the area under the seat, in front of the rear fender.

RETURN TO SERVICE

NOTE

Verify that the ignition key switch is in the OFF position **before** installing the main fuse.

1. Refer to the service manual and follow the instructions to install the main fuse.
2. Turn the ignition key switch to IGNITION, but do not start the motorcycle.
3. Test for proper tail, stop and turn signal lamp operation.

⚠ WARNING

After installing seat, pull upward on seat to be sure it is locked in position. While riding, a loose seat can shift causing loss of control, which could result in death or serious injury. (00070b)

4. Refer to the service manual, and follow instructions to install the seat.

SERVICE PARTS

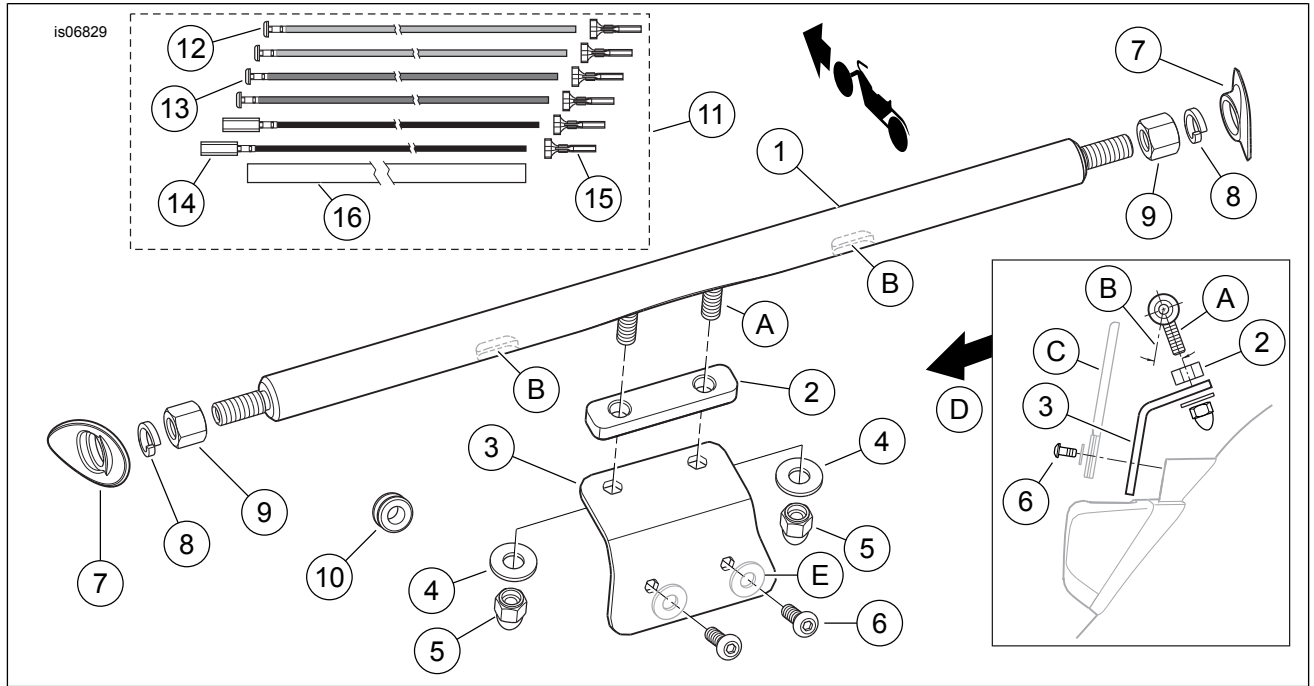

Figure 3. Service Parts, XL1200C Turn Signal Relocation Kit

Table 1. Service Parts

Item	Description (Quantity)	Part Number
1	Turn signal relocation light bar assembly	Not sold separately
2	Spacer	Not sold separately
3	Relocation mount	Not sold separately
4	Plain washer, 1/4 in ID (2)	6339
5	Acorn nut, 1/4-20, chrome (2)	94004-90T
6	Cap screw, hex socket button head, #10-32 x 5/8 inch (2)	Not sold separately
7	Recess cover, turn signal lamp housing, chrome (2)	68028-03
8	Lockwasher, helical spring, 8 mm (5/16 in) nominal ID (2)	7042
9	Hex nut, chrome (2)	7849
10	Grommet	11410
11	Wire harness components, rear lighting (includes items 12 through 16)	Not sold separately
12	• Wire, blue (2)	Not sold separately
13	• Wire, violet (2)	Not sold separately
14	• Wire, black (2)	Not sold separately
15	• Socket terminal, #18-22 gauge (6)	Not sold separately
16	• Protective tubing, 60 inch (150 cm)	Not sold separately
Items mentioned in text, but not included in kit:		
A	Threaded studs on light bar assembly, 1/4-20 in	
B	Oblong wire-exit hole (orientation shown in inset side view) (2)	
C	Original equipment (OE) license plate bracket	
D	Side view in direction of arrow	
E	OE washer, #10 (0.19 in) nominal ID (2)	