



INSTRUCTIONS

-J03018

REV. 2007-07-22

BILLET HEADLAMP SHELL

GENERAL

Kit Number

67704-03

Models

For model fitment information, please see the P&A Retail Catalog or the Parts and Accessories section of www.harley-davidson.com (English only).

Additional Parts Required

WARNING

The rider's safety depends upon the correct installation of this kit. Use the appropriate service manual procedures. If the procedure is not within your capabilities or you do not have the correct tools, have a Harley-Davidson dealer perform the installation. Improper installation of this kit could result in death or serious injury. (00333a)

NOTE

This instruction sheet references Service Manual information. A Service Manual for your model motorcycle is required for this installation and is available from a Harley-Davidson dealer.

Proper installation of this kit requires the use of Snap-on® Pick Tool (TT600-3) and a silicone based lubricant, which can be purchased at a Harley-Davidson dealer.

Kit Contents

See Figure 15 and Table 3.

REMOVAL

Softail and Dyna Models

1. Remove the windshield (if equipped).
2. Remove the seat according to the procedure in the applicable Service Manual.

WARNING

To prevent spray of fuel, purge system of high-pressure fuel before supply line is disconnected. Gasoline is extremely flammable and highly explosive, which could result in death or serious injury. (00275a)

NOTE

Before disconnecting battery, fuel pressure must be relieved from the fuel lines of the EFI system. Refer to the applicable Service Manual for instructions.

WARNING

Stop the engine when refueling or servicing the fuel system. Do not smoke or allow open flame or sparks near gasoline. Gasoline is extremely flammable and highly explosive, which could result in death or serious injury. (00002a)

3. *FXST/B/D models:* Remove fuel tank. Refer to FUEL TANK CARBURETED or FUEL TANK: EFI in Service Manual.
FXDWG models: Remove fuel tank. Refer to FUEL TANK in Service Manual.

WARNING

To prevent accidental vehicle start-up, which could cause death or serious injury, disconnect negative (-) battery cable before proceeding. (00048a)

WARNING

Disconnect negative (-) battery cable first. If positive (+) cable should contact ground with negative (-) cable connected, the resulting sparks can cause a battery explosion, which could result in death or serious injury. (00049a)

4. Disconnect battery cables, negative (-) cable first.
5. See Figure 1. Disconnect headlamp connector (1) from vehicle harness.
6. Remove nut (2), screw (3), and trim ring (4) from headlamp.

NOTE

Save the following items for reuse:

- Lens assembly (5) (includes gasket and boot)
 - Adapter ring (7)
 - Wiring harness (10) includes wiring connector block (6), headlamp connector (1), and grommet (9)
 - Lockwasher (12)
7. Remove lens assembly (5) and disconnect wiring connector block (6) from bulb prongs.

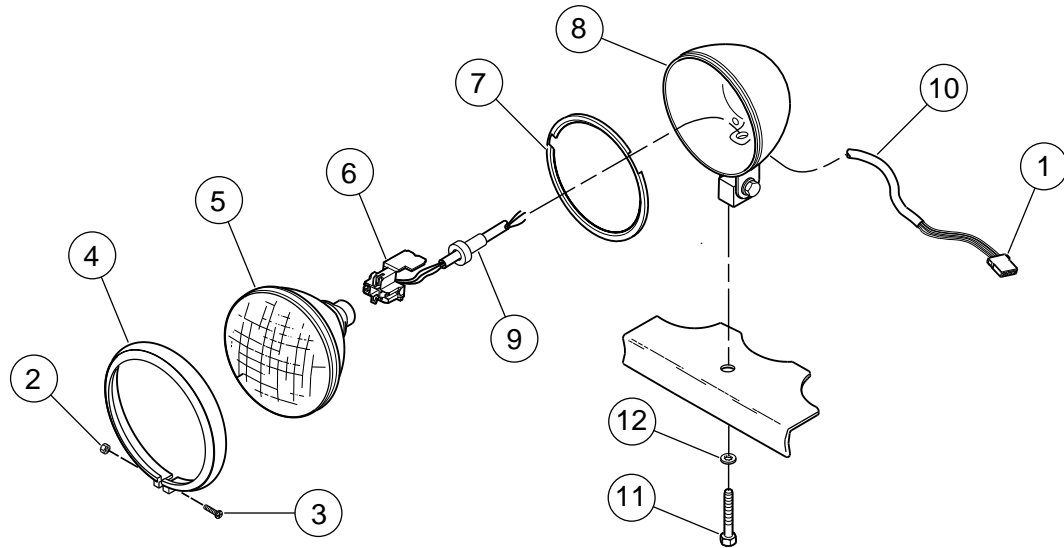

- | | |
|---|--|
| <ol style="list-style-type: none"> 1. Headlamp connector 2. Nut 3. Screw 4. Trim ring 5. Lens assembly (includes gasket and boot) 6. Wiring connector block | <ol style="list-style-type: none"> 7. Adapter ring (wave-shape cross section shown) 8. Headlamp shell assembly 9. Grommet 10. Headlamp wire harness (includes 1, 6, and 9) 11. Bolt 12. Lockwasher |
|---|--|

Figure 1. Headlamp Assembly (Softail and Dyna Models)

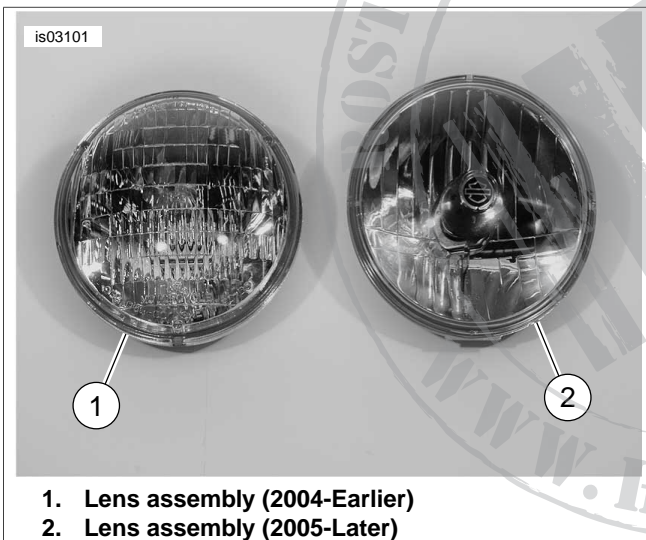

1. Lens assembly (2004-Earlier)
2. Lens assembly (2005-Later)

Figure 2. Headlamp Lens Assembly

8. Remove adapter ring (7) from headlamp shell assembly (8).

NOTE

Record the location of the wires in the connector before removing.

9. Remove headlamp connector (1) from headlamp wire harness using a pick tool (Snap-on® TT600-3).

10. Work the grommet (9) through the hole in the headlamp shell (from outside of shell) using a small flat bladed screwdriver, and remove headlamp wire harness (with grommet) (10) from headlamp shell.

If harness is equipped with an internal ground wire, cut ground wire off and tape end of wire with electrical tape.

11. Remove bolt (11), lockwasher (12), and headlamp shell assembly (8).

VRSCA Models

Remove original equipment headlamp assembly. Refer to Instruction Sheet -J03720 for procedures.

NOTE

VRSCA models require the separate purchase of Headlamp 68297-05, which is available from a Harley-Davidson dealer.

VRSCB Models

Remove original equipment headlamp assembly. Refer to Instruction Sheet -J03720 for procedures.

NOTE

VRSCB models use the original equipment headlamp (and gasket).

INSTALLATION

Wiring Harness and Headlamp Mounting Block Assembly

NOTE

Use caution during installation, to prevent scratching the headlamp shell, mount and mounting block.

1. See Figure 3. Feed headlamp wire harness (with grommet) (1) through hole in billet headlamp shell (2), but do not seat grommet (3) in hole.
2. *Softail and Dyna:* Install harness wires into connector (4) in same locations as noted in removal.
VRSC: Refer to Instruction Sheet -J03720 for harness wire connection.

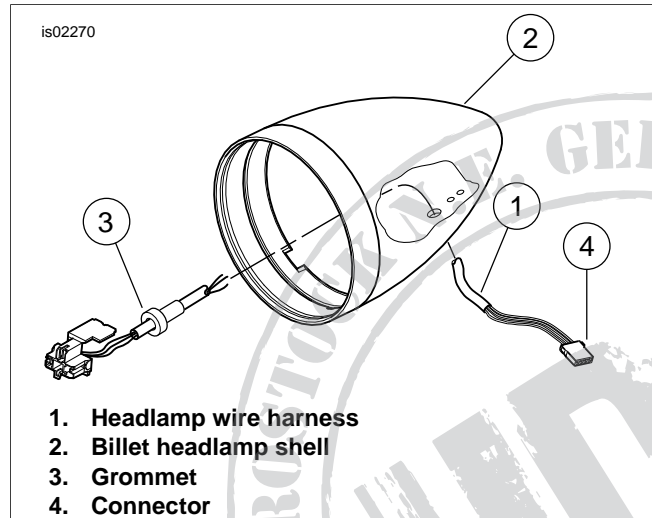

Figure 3. Install Wiring Harness in Billet Headlamp Shell

3. See Figure 4. Install billet headlamp mount (1) to headlamp shell (2) using two 1/4-20 x 7/8 in. screws (3), lockwashers (4), and locknuts (5) supplied in kit. Align mount and tighten hardware until snug.

NOTE

The wiring harness should be routed along the top of the mounting block.

4. See Figure 5. Install mounting block (1) to headlamp/mount assembly (2) using two 3/8-16 x 3/4 in. screws (3), lockwashers (4), and flat washers (5) from kit. Align mounting block and tighten hardware until snug.
5. *Softail and Dyna:* See Figure 6. Install headlamp shell and mounting block assembly (1) onto headlamp mounting plate/lower bracket (2) using a 3/8-16 x 1-3/4 in. screw (3) from kit and lockwasher (4) previously removed. Align shell and mounting block, and tighten screw to 31 ft-lbs (42 Nm).

VRSC: Refer to Instruction Sheet -J03720 to install headlamp shell and mounting block onto lower triple clamp.

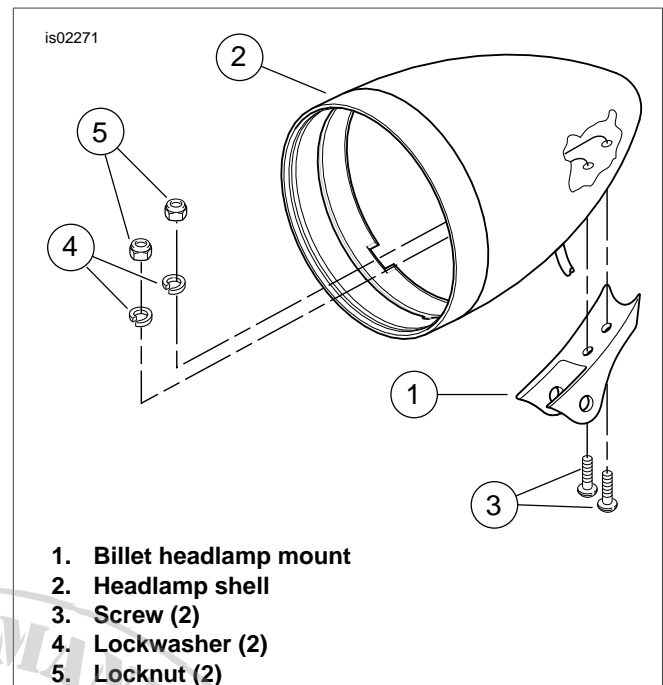

Figure 4. Install Headlamp Mount to Headlamp Shell

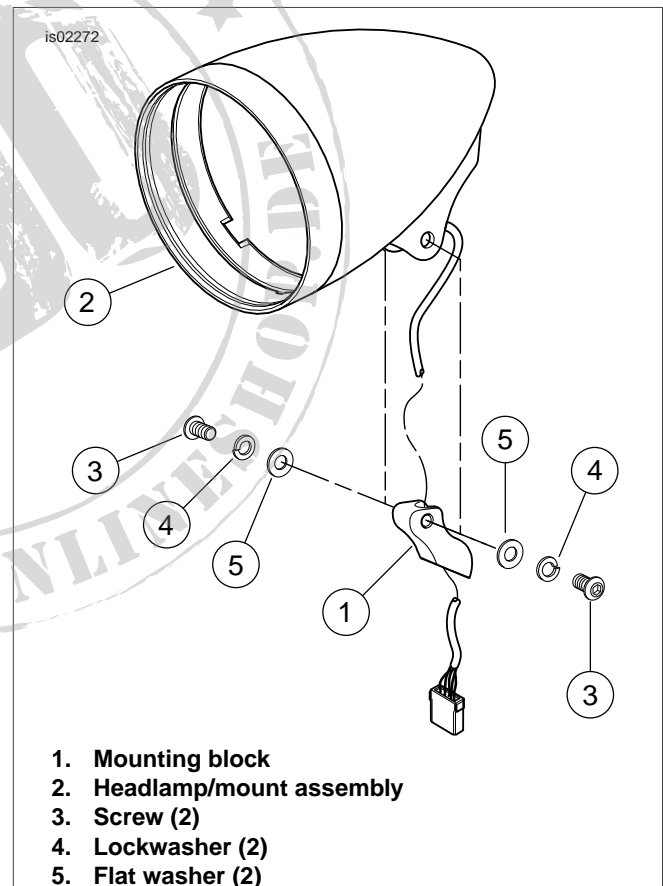

Figure 5. Install Billet Headlamp Mounting Block on Headlamp/Mount Assembly

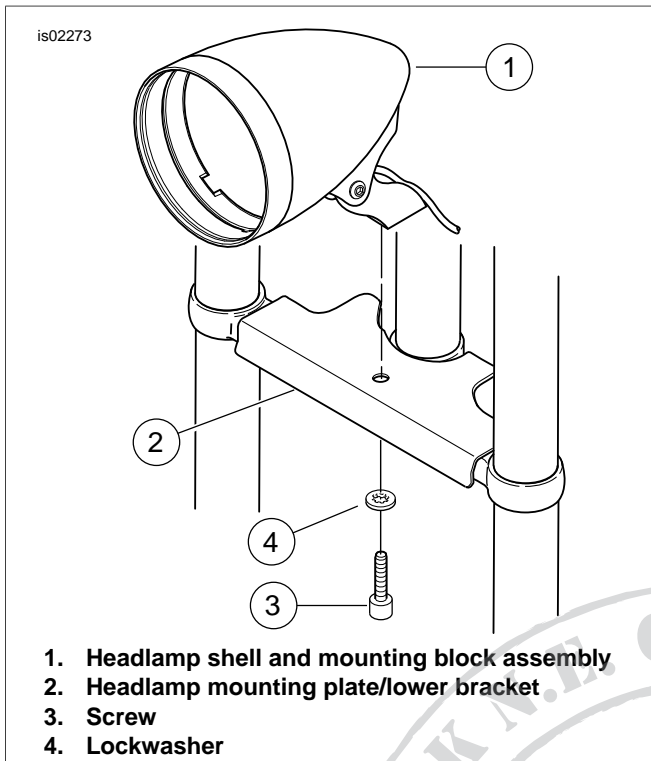

Figure 6. Install Headlamp Shell and Mounting Block

6. See Figure 4. Tighten 1/4 in. hardware previously installed to 108 in-lbs (12 Nm).
7. See Figure 5. Place a protective covering between top of headlamp shell and bottom of upper bracket (Softtail and Dyna) or top triple clamp (VRSC) (not shown). Tilt headlamp shell back until it just misses bottom of upper bracket/top triple clamp. Tighten screw (3) to 31 ft-lbs (42 Nm).

Headlamp Assembly

1. *Softtail and Dyna Models:*
 - a. *2004 and earlier:* See Figure 7. Install gasket from kit over boot and existing gasket. Position gasket according to the adapter ring (wave-shape or L-shape cross section) equipped with lens assembly.
 - b. *2005 and later:* See Figure 8. Install gasket from kit over boot and existing gasket. Position gasket according to the adapter ring (wave-shape or L-shape cross section) equipped with lens assembly.

VRSC Models:

- a. See Figure 8. Install gasket from kit over boot and existing gasket. Position gasket according to the adapter ring (L-shape cross section) in VRSC Bracket for Billet Headlamp Shell Kit 68211-05.

NOTE

The adapter ring will be installed with the outer flange facing out, and positioned as described in the following step.

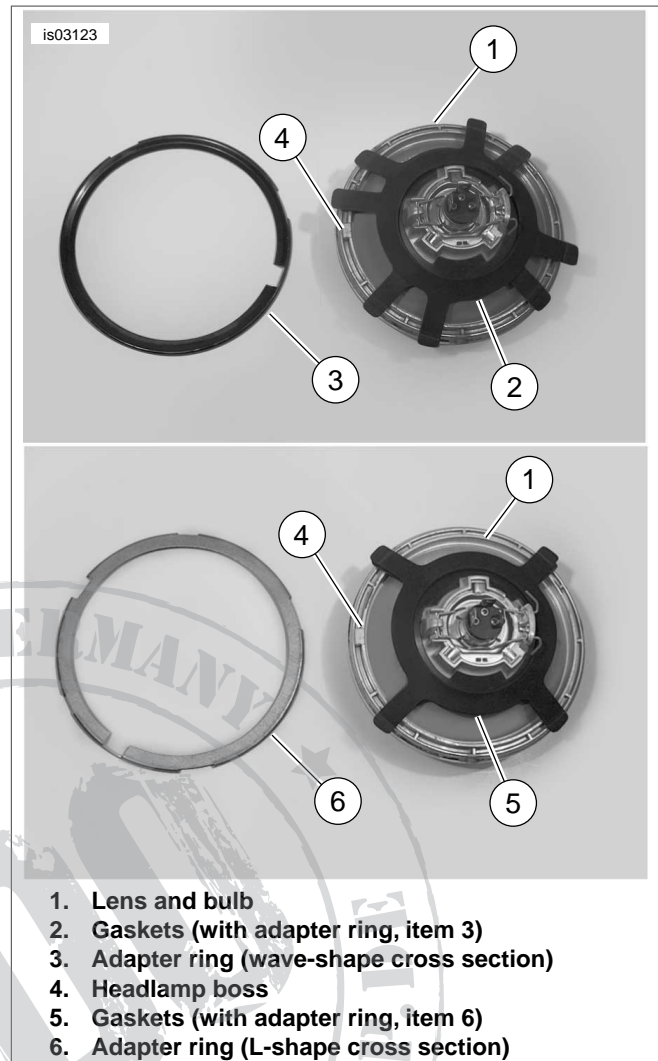
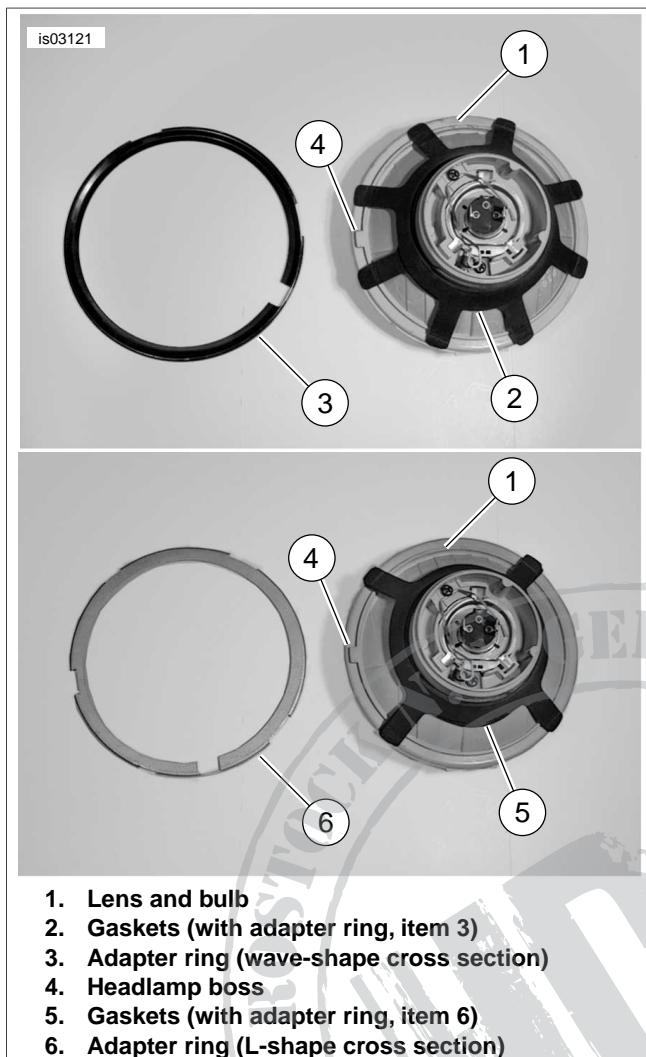

Figure 7. Install Gasket (2004-Earlier Lens Assembly)



1. Lens and bulb
2. Gaskets (with adapter ring, item 3)
3. Adapter ring (wave-shape cross section)
4. Headlamp boss
5. Gaskets (with adapter ring, item 6)
6. Adapter ring (L-shape cross section)

Figure 8. Install Gasket (2005-Later Lens Assembly)

2. See Figure 9. Install adapter ring (1) in headlamp shell (2), with lens boss cut-out (3) at 3 o'clock position and shell boss cut-out (4) at 8 o'clock position. VRSC models use adapter ring from Billet Headlamp Shell Kit (68211-05).
3. Install 3-prong connector (5) onto rear of lens assembly.

NOTE

When installing the lens assembly into the shell, make sure the wiring harness grommet is seated in the hole in the shell.

4. Install lens assembly (6) into headlamp shell (2), aligning headlamp boss (7) with lens boss cut-out (3) on adapter ring. The headlamp gasket tabs should be sandwiched between the outside diameter of the lens assembly and the adapter ring.
5. See Figure 10. Snap retaining ring (1) from kit into groove in headlamp shell (2). It may be necessary to use a needle nose pliers for leverage to install retaining ring. The retainer should push up against front of lens. Position retainer so it does not hit headlamp bosses (3) on front of lens. Gap in retaining ring (4) should be positioned at bottom dead center.

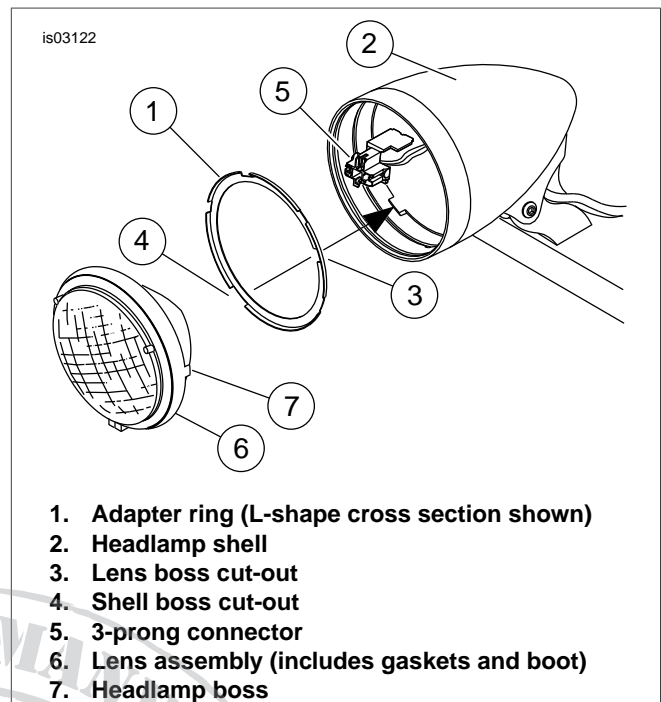

1. Adapter ring (L-shape cross section shown)
2. Headlamp shell
3. Lens boss cut-out
4. Shell boss cut-out
5. 3-prong connector
6. Lens assembly (includes gaskets and boot)
7. Headlamp boss

Figure 9. Install Lens Assembly

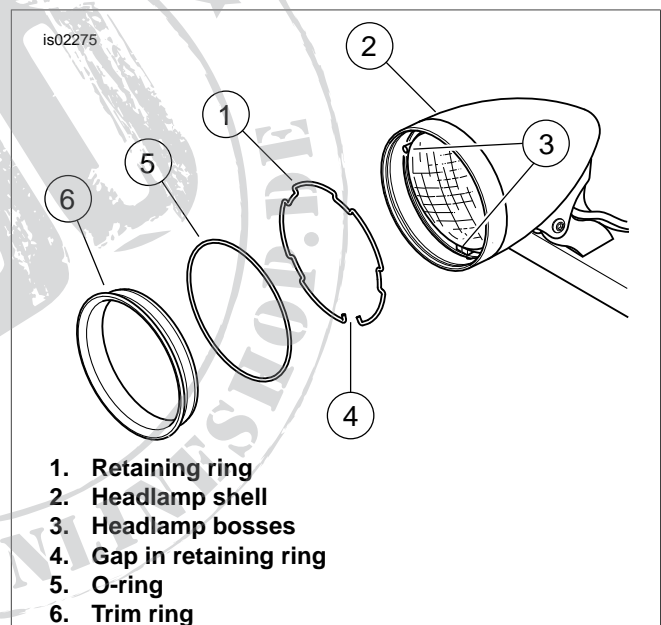

1. Retaining ring
2. Headlamp shell
3. Headlamp bosses
4. Gap in retaining ring
5. O-ring
6. Trim ring

Figure 10. Install Trim Ring

NOTE

Do not use a petroleum based lubricant on the trim ring O-ring. Petroleum based lubricants will make the O-ring swell and make the headlamp difficult to disassemble.

6. Apply a light coat of silicone based lubricant (or soap if a silicone lubricant is not available) on the O-ring (5) surface. This will aid in disassembly of headlamp when servicing at a later date.
7. Install O-ring (5) over groove in trim ring (6).
8. Connect headlamp connector to vehicle wire harness.

Softail and Dyna Models

WARNING

Stop the engine when refueling or servicing the fuel system. Do not smoke or allow open flame or sparks near gasoline. Gasoline is extremely flammable and highly explosive, which could result in death or serious injury. (00002a)

NOTE

Be sure that wiring harness does not get pinched between fuel tank and frame during tank installation.

1. *FXST/B/D models:* Install fuel tank. Refer to FUEL TANK CARBURETED or FUEL TANK: EFI in Service Manual.
FXDWG models: Install fuel tank. Refer to FUEL TANK in Service Manual.

WARNING

Connect positive (+) battery cable first. If positive (+) cable should contact ground with negative (-) cable connected, the resulting sparks can cause a battery explosion, which could result in death or serious injury. (00068a)

2. Connect battery cables, positive (+) cable first.

WARNING

After installing seat, pull upward on seat to be sure it is locked in position. While riding, a loose seat can shift causing loss of control, which could result in death or serious injury. (00070b)

3. Install seat according to the instructions in the Service Manual.

4. Align headlamp as described in the alignment procedure in the applicable Service Manual. Tighten headlamp mounting hardware to 31 ft-lbs (42 Nm).

NOTE

Do not use a petroleum based lubricant on the trim ring O-ring. Petroleum based lubricants will make the O-ring swell and make the headlamp difficult to disassemble.

5. See Figure 10. Install trim ring (6) with O-ring (5) into headlamp shell (2). Use a silicone based lubricant (or soap if a silicone lubricant is not available) on the O-ring outer diameter to ease installation.
6. Trim windshield (if equipped). See "Trim Windshield" in this Instruction Sheet.
7. Install windshield (if equipped). Refer to appropriate Instruction Sheet for procedures.

VRSC Models

1. Install right side cover and maxi-fuse. Refer to MAXI-FUSE in Service Manual.
2. Align headlamp as described in the alignment procedure in the applicable Service Manual. Tighten headlamp mounting hardware to 31 ft-lbs (42 Nm).

NOTE

Do not use a petroleum based lubricant on the trim ring O-ring. Petroleum based lubricants will make the O-ring swell and make the headlamp difficult to disassemble.

3. See Figure 10. Install trim ring (6) with O-ring (5) into headlamp shell (2). Use a silicone based lubricant (or soap if a silicone lubricant is not available) on the O-ring outer diameter to ease installation.
4. Trim windshield (if equipped). See "Trim Windshield" in this Instruction Sheet.
5. Install windshield (if equipped). Refer to appropriate Instruction Sheet for procedures.

TRIM WINDSHIELD

Table 1. FXST/FXSTB/FXDWG Windshield

Windshield Part Number	Description	Amount to Trim (1)
Rigid Windshields		
91820-85A	Sport Windshield	Fits as is (None)
58025-91B 58059-93A	Compact Windshield	Higher Position - Fits as is (None) Trim as desired, to a maximum of 1 in. (25 mm)
Detachable Windshields (Using Docking Kit 58350-96)		
58340-96 58627-99 58341-96	Compact Windshield	Fits as is (None)
57965-97A	Super Sport Windshield	5/16 in. (8 mm)

Table 2. FXSTD Windshield

Windshield Part Number	Description	Amount to Trim (1)
Detachable Windshields (Using Docking Kit 58397-00)		
57090-00A 57824-00A	Compact Windshield	1-1/4 to 1-1/2 in. (32 to 38 mm)
57837-00A	Super Sport Windshield	1-1/4 to 1-1/2 in. (32 to 38 mm)

NOTE

This section applies to Softail and Dyna models. It does not apply to VRSC models.

This procedure explains how to trim a Harley-Davidson windshield in order to gain needed clearance for the new headlamp shell. Refer to the appropriate chart for your model motorcycle and windshield type to determine the amount that your windshield may need to be trimmed.

1. See Figure 11. Cover an area extending approximately 2 in. (50 mm) from windshield headlamp opening with two layers of masking tape on both sides of windshield. This tape provides a surface on which to mark the cut, as well as to protect the windshield while cutting.
2. Mark amount to be trimmed (1) on the tape. Maintain existing radius (2) when marking new opening.
3. Using a saber saw with a fine-toothed blade, carefully cut new opening on windshield.

4. Clean edges of new opening with a fine-grit grinding wheel.
5. Remove tape.

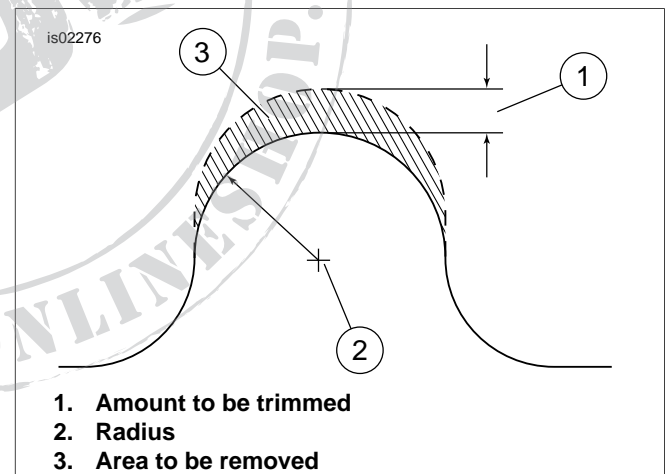

Figure 11. Windshield Trimming Dimensions

LENS AND BULB REPLACEMENT

Disassembly

⚠ WARNING

Disconnect negative (-) battery cable first. If positive (+) cable should contact ground with negative (-) cable connected, the resulting sparks can cause a battery explosion, which could result in death or serious injury. (00049a)

1. Softail and Dyna Models:
 - a. Remove seat according to the instructions in the Service Manual.
 - b. Disconnect battery cables, negative (-) cable first.

VRSC Models:

 - a. Remove right side cover and maxi-fuse. Refer to MAXI-FUSE in Service Manual.
2. See Figure 12. Cover tip of small slotted screwdriver with duct tape, and insert tip of screwdriver into opening (1) at bottom of headlamp shell. Twist screwdriver to move bottom of trim ring (2) out approximately 0.12 in. (3 mm).

NOTES

If a cotter pin extractor (pick with a 90° bend) is available, it can be used as a small pry bar in place of a screwdriver.

Small flat washers or pennies can be used as shims, as each washer/penny is approximately 0.060 in. (1.5 mm) thick.

The trim ring can be removed without damaging either the trim ring or headlamp shell. Taping the shims in place allows one person to remove the trim ring without damaging the chrome.

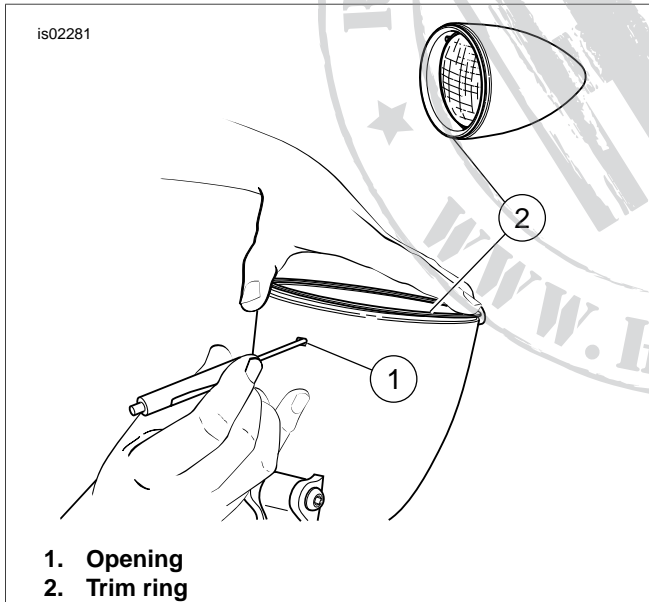

Figure 12. Pry Bottom of Trim Ring Away from Headlamp Shell

3. See Figure 13. Insert shim(s) (1) equal to approximately 0.12 in. (3 mm) in gap between trim ring (2) and headlamp shell (3). Tape shim(s) to trim ring and headlamp shell to hold them in place.
4. Insert a 0.06 in. (1.5 mm) shim (4) into gap to the right of shims at the bottom of trim ring, and slide shim in gap counterclockwise until it sticks. The shim should now be

at approximately the 2 or 3 o'clock position. Tape shim in place.

5. Insert a 0.06 in. (1.5 mm) shim (5) into gap to the left of shims at the bottom of trim ring, and slide shim in gap clockwise until it sticks. The shim should now be at approximately the 9 or 10 o'clock position. Tape shim in place.

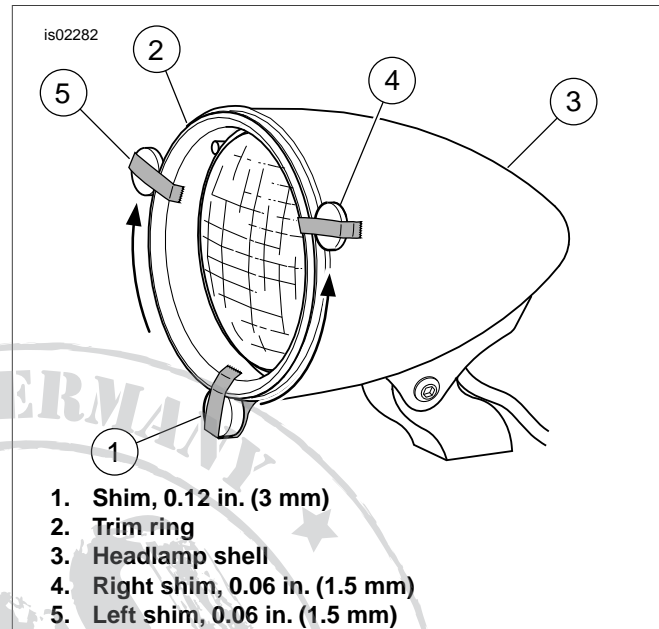

Figure 13. Remove Trim Ring

6. Cover tip of a small slotted screwdriver with duct tape, and insert tip of screwdriver in gap between 0.06 in. (1.5 mm) shims (4 and 5) and bottom of headlamp shell. Starting near shims, and alternating from side to side, carefully pry trim ring from headlamp shell.
7. See Figure 14. Using a needle nose pliers, remove retaining ring (1) from groove in headlamp shell (2).
8. Carefully pull lens assembly (3) out of headlamp shell, and disconnect wiring connector block (4) from bulb prongs.
9. Remove boot (5) and gasket (6), and gasket (7) from lens assembly.

CAUTION

Never touch the quartz bulb. Fingerprints will etch the glass and decrease bulb life. Grab the bulb with paper or a clean, dry cloth. Failure to do so could result in bulb damage. (00210a)

⚠ WARNING

Handle bulb carefully and wear eye protection. Bulb contains gas under pressure, which, if not handled carefully, could cause serious eye injury. (00062b)

10. Replace headlamp bulb according to the procedure in the applicable Service Manual.

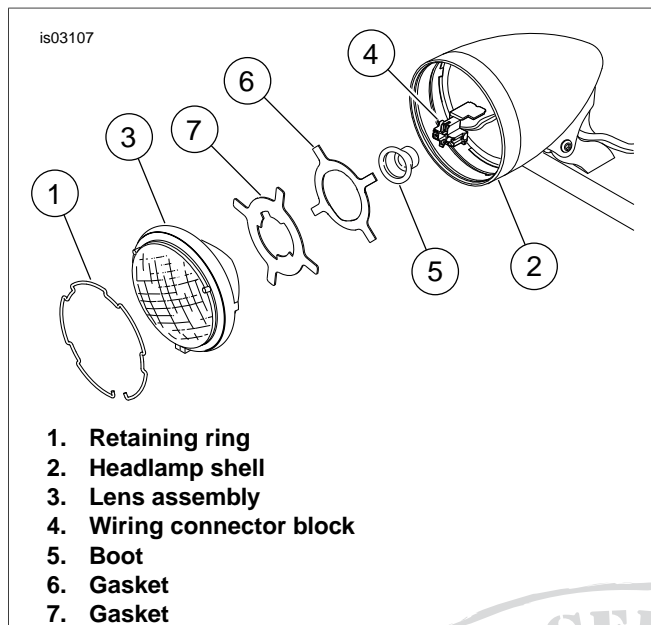

Figure 14. Remove Lens Assembly

Headlamp Assembly

1. Softail and Dyna Models:

- a. *2004 and earlier:* See Figure 7. Install gasket from kit over boot and existing gasket. Position gasket according to the adapter ring (wave-shape or L-shape cross section) equipped with lens assembly.
- b. *2005 and later:* See Figure 8. Install gasket from kit over boot and existing gasket. Position gasket according to the adapter ring (wave-shape or L-shape cross section) equipped with lens assembly.

VRSC Models:

- a. See Figure 8. Install gasket from kit over boot and existing gasket. Position gasket according to the adapter ring (L-shape cross section) in VRSC Bracket for Billet Headlamp Shell Kit 68211-05.

NOTE

The adapter ring will be installed with the outer flange facing out, and positioned as described in the following step.

2. See Figure 9. Install adapter ring (1) in headlamp shell (2), with lens boss cut-out (3) at 3 o'clock position and shell boss cut-out (4) at 8 o'clock position. VRSC models use adapter ring from Billet Headlamp Shell Kit (68211-05).
3. Install 3-prong connector (5) onto rear of lens assembly.

NOTE

When installing the lens assembly into the shell, make sure the wiring harness grommet is seated in the hole in the shell.

4. Install lens assembly (6) into headlamp shell (2), aligning headlamp boss (7) with lens boss cut-out (3) on adapter ring. The headlamp gasket tabs should be sandwiched between the outside diameter of the lens assembly and the adapter ring.
5. See Figure 10. Snap retaining ring (1) from kit into groove in headlamp shell (2). It may be necessary to use a needle nose pliers for leverage to install retaining ring. The

retainer should push up against front of lens. Position retainer so it does not hit headlamp bosses (3) on front of lens. Gap (4) in retaining ring should be positioned at bottom dead center.

NOTE

Do not use a petroleum based lubricant on the trim ring O-ring. Petroleum based lubricants will make the O-ring swell and make the headlamp difficult to disassemble.

6. Apply a light coat of silicone based lubricant (or soap if a silicone lubricant is not available) on the O-ring (5) surface. This will aid in disassembly of headlamp when servicing at a later date.
7. Install O-ring (5) over groove in trim ring (6).

Softail and Dyna Models:

⚠ WARNING

Connect positive (+) battery cable first. If positive (+) cable should contact ground with negative (-) cable connected, the resulting sparks can cause a battery explosion, which could result in death or serious injury. (00068a)

1. Connect battery cables, positive (+) cable first.

⚠ WARNING

After installing seat, pull upward on seat to be sure it is locked in position. While riding, a loose seat can shift causing loss of control, which could result in death or serious injury. (00070b)

2. Install seat according to the instructions in the Service Manual.
3. Align headlamp as described in the alignment procedure in the applicable Service Manual. Tighten headlamp mounting hardware to 31 ft-lbs (42 Nm).

NOTE

Do not use a petroleum based lubricant on the trim ring O-ring. Petroleum based lubricants will make the O-ring swell and make the headlamp difficult to disassemble.

4. See Figure 10. Install trim ring (6) with O-ring (5) into headlamp shell (2). Use a silicone based lubricant (or soap if a silicone lubricant is not available) on the O-ring outer diameter to ease installation.

VRSC Models:

1. Install right side cover and maxi-fuse. Refer to MAXI-FUSE in Service Manual.
2. Align headlamp as described in the alignment procedure in the applicable Service Manual. Tighten headlamp mounting hardware to 31 ft-lbs (42 Nm).

NOTE

Do not use a petroleum based lubricant on the trim ring O-ring. Petroleum based lubricants will make the O-ring swell and make the headlamp difficult to disassemble.

3. See Figure 10. Install trim ring (6) with O-ring (5) into headlamp shell (2). Use a silicone based lubricant (or soap if a silicone lubricant is not available) on the O-ring outer diameter to ease installation.

SERVICE PARTS

is03112

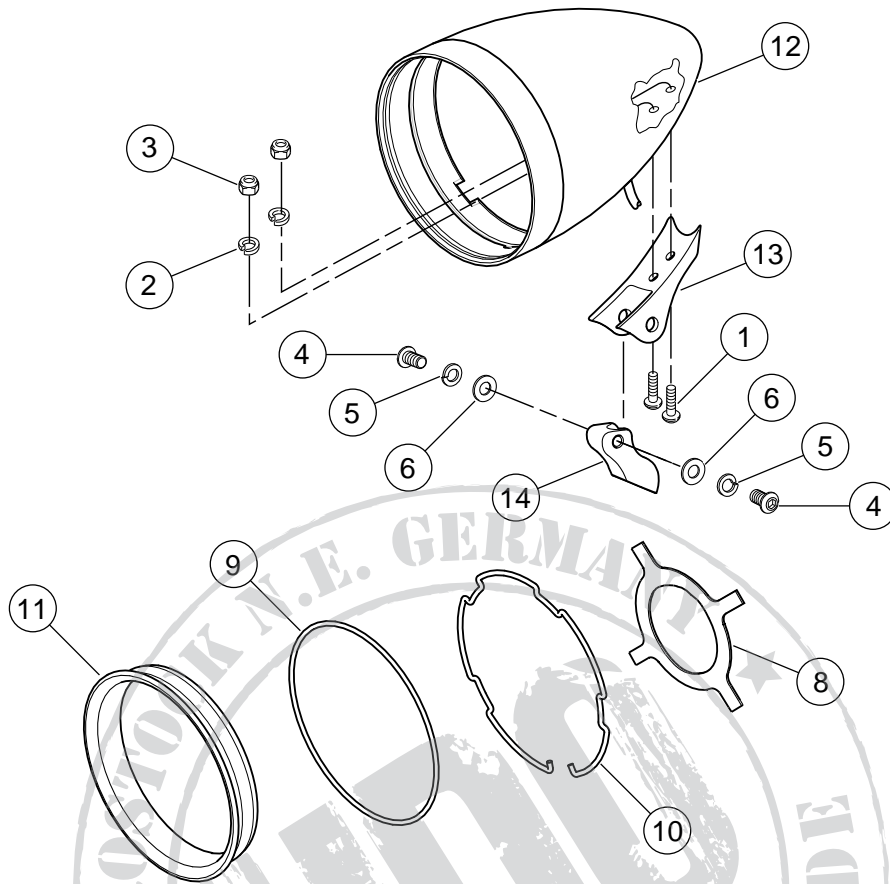

Figure 15. Service Parts: Billet Headlamp Shell

Table 3. Service Parts: Billet Headlamp Shell

Item	Description (Quantity)	Part Number	Item	Description (Quantity)	Part Number
1	Screw, hex socket button 1/4-20 x 7/8 in. (2)	94387-92T	9	O-ring	11385
2	Lockwasher (2)	94080-90T	10	Retaining ring	67706-03
3	Locknut, 1/4-20 (2)	7686	11	Trim ring	67709-03
4	Screw, hex socket button 3/8-16 x 3/4 in. (2)	94399-92T	12	Shell, billet headlamp	Not Sold Separately
5	Lockwasher, 3/8 in. (2)	94082-90T		Mount kit	67754-03
6	Washer, flat, chrome 3/8 in. (2)	94067-90T	13	• Mount	Not Sold Separately
7	Screw, hex socket head 3/8-16 x 1-3/4 in. (not shown)	94357-91T	14	• Mounting block	Not Sold Separately
8	Gasket	67601-94A			