



INSTRUCTIONS

-J02572

REV. 06-06-2002

Kit Number 66050-03

LOWER FORK BRACKET (TRIPLE TREE) COVER KIT

General

This kit fits all 1994 and later FLHR/I (Road King) and FLHRCI (Road King Classic) model motorcycles.

See the Service Parts illustration for a list of items contained in this kit.

NOTE

A Service Manual for your model motorcycle is available from your Harley-Davidson dealer.

Installation

1. **For models equipped with air baffle:** See Figure 1. Remove and discard the two hex screws (2) and flat washers (3) holding the baffle (1) to the fork stem and bracket assembly (4). Retain the baffle for later reassembly.

For models not equipped with air baffle: Remove and discard the two plugs from the rear of the fork stem and bracket assembly (4).

2. Remove and discard the hex socket head screw (6) holding the brake line manifold (5) to the underside of the fork stem and bracket assembly.
3. Place the lower fork bracket cover into position covering the brake line manifold. Attach the cover (and the baffle, if so equipped) to the fork stem and bracket assembly with the two 1/4" self-tapping hex screws from the kit. Tighten securely.
4. Install the 5/16" self-tapping hex socket screw through the cover and brake line manifold into the stem and bracket assembly. Torque to 10-15 ft-lbs (13.6-20.3 Nm).
5. Verify that the throttle and clutch cables are routed properly and do not interfere with steering the vehicle.

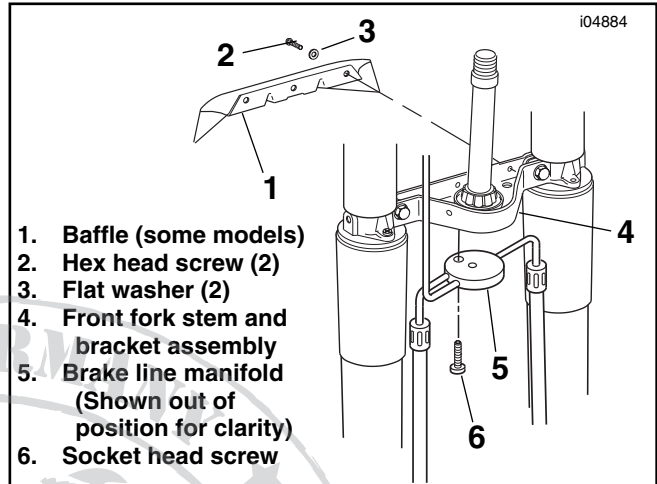

Figure 1. Lower Fork Bracket

WARNING

After disturbing the brake system, **BEFORE** moving motorcycle, you must pump brake fluid until the pistons push the pads against the brake disc. If you don't pump fluid pressure up again, the brake will not be available to stop the motorcycle which could result in death or serious injury.

WARNING

After disturbing the brake system, always test motorcycle brakes at low speed. If brakes are not operating properly, or braking efficiency is poor, testing at high speeds could result in death or serious injury.



Service Parts

Part No. 66050-03

Date 05/02

Lower Fork Bracket (Triple Tree) Cover

i04885

Item	Description	Part No.
1	Cover, Triple Tree	Not sold
2	Screw, Hex Head, 1/4"-20 x 5/8", Self-Tapping (Chrome) (2)	3892
3	Washer, Flat, 1/4" (Chrome) (2)	6703
4	Screw, Hex Socket Head, 5/16"-18 x 1", Self-Tapping (Chrome)	3331

