



INSTRUCTIONS

-J02843

REV. 2007-01-10

BILLET CLUTCH CABLE ADJUSTER COVER KIT

GENERAL

Kit Number

64108-03

Models

For model fitment information, please see the P&A Retail Catalog or the Parts and Accessories section of www.harley-davidson.com (English only).

Additional Parts Required

Installing this kit on XL models requires the separate purchase of a Billet Chrome Cable Clamp Kit, part number 91147-02. This kit is optional for Softail models.

Loctite® 262 Threadlocker and Sealant - Blue

WARNING

The rider's safety depends upon the correct installation of this kit. If the procedure is not within your capabilities or you do not have the correct tools, have a Harley-Davidson dealer perform the installation. Improper installation of this kit could result in death or serious injury. (00308a)

Kit Contents

See Figure 1 and Table 1.

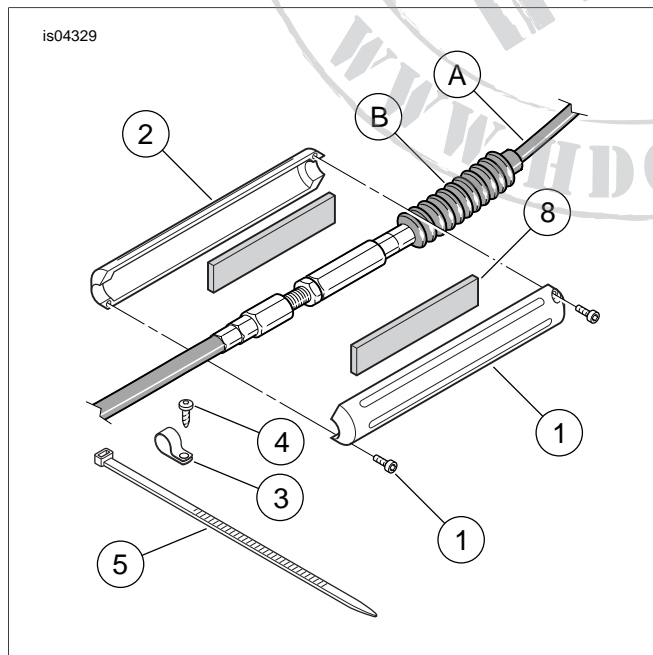

Figure 1. Service Parts: Billet Clutch Cable Adjuster Cover

Table 1. Service Parts

Item	Description (Quantity)	Part Number
1	Cover, clutch cable adjuster, top half	Not Sold Separately
2	Cover, clutch cable adjuster, bottom half	Not Sold Separately
3	Clamp, 7/16 inch diameter	38712-68
4	Screw, TORX®, self-tapping, 8-32 x 3/8 inch	68042-99
5	Cable strap, 7.5 inch	10006
6	Screw and cushion kit	64111-03
7	• Screw (2)	Not Sold Separately
8	• Cushion (2)	Not Sold Separately
Items mentioned in text, but not included in kit.		
A	Clutch cable	
B	Clutch cable adjuster	

INSTALLATION

- Dyna Models:** Remove the plastic clip that fastens the clutch cable to the frame downtube just below the clutch cable adjuster and boot. Leave the clip above the adjuster in place.
Softail Models: Remove the plastic clip and screw that attaches the clutch cable to the frame downtube just above the clutch cable adjuster and boot.
- ALL Models:** See Figure 1. Cut the original rubber boot (B) from the clutch cable (A). Make sure that the clutch cable covering is not cut or damaged.
- Obtain the two halves of the clutch cable adjuster cover (items 1 and 2) and two cushions (8). Peel the paper backing from one cushion (8), and center the cushion on the inside of one cover half. Repeat for the other cushion and cover half.
- Obtain the two screws (7) from the kit. Position the cover halves on each side of the cable adjuster, and align the screw holes at each end. Place a drop of Loctite 243 - Blue on the screw threads, and fasten the cover halves with the two screws. Tighten to 21 **in-lbs** (2.4 Nm).

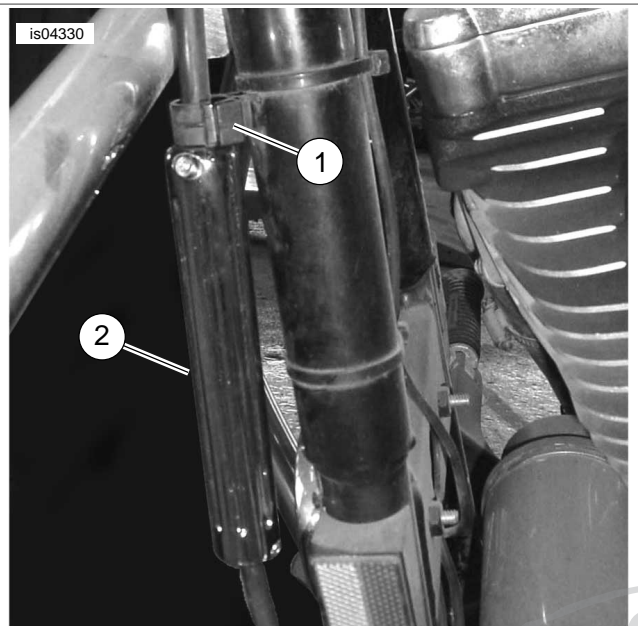

1. Stock Plastic Clip
2. Clutch Cable Adjuster Cover

Figure 2. Install Clutch Cable Adjuster Cover, Dyna

Dyna Models

5. See Figure 2. Installation is complete. Proceed to Step 8.

XL Models

6. See Figure 3. Install the Billet Chrome Cable Clamp Kit (purchased separately) to the motorcycle frame downtube about two inches (51 mm) above the adjuster cover per the instructions in that kit. Position the bracket so the cable is outboard and parallel to the frame downtube. Proceed to Step 8.

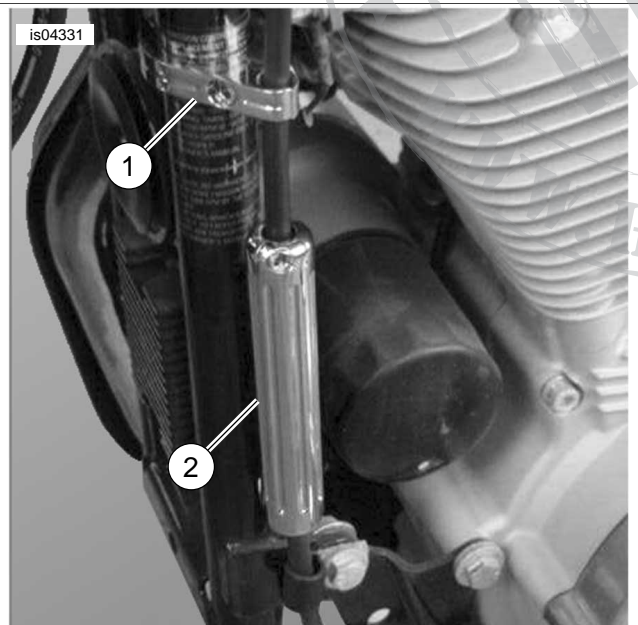

1. Billet Chrome Cable Clamp
2. Clutch Cable Adjuster Cover

Figure 3. Install Clutch Cable Adjuster Cover, XL

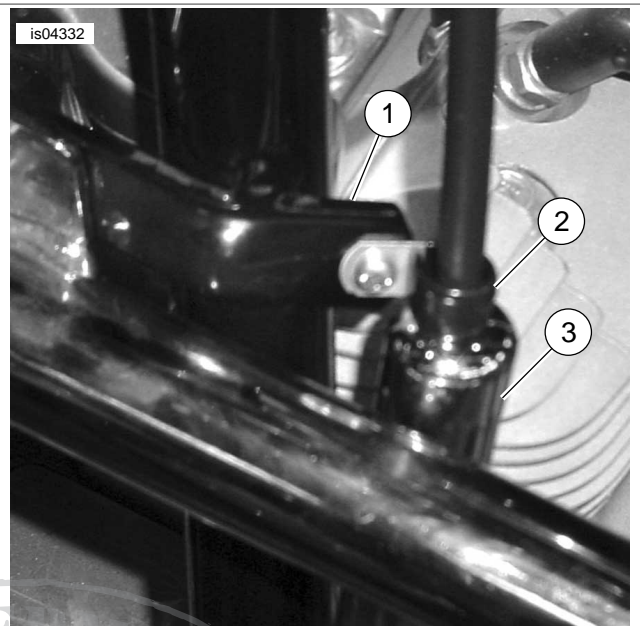

1. Frame Downtube
2. Clamp
3. Clutch Cable Adjuster Cover

Figure 4. Upper Clamp Position, Softails

Softail Models

NOTE

Upper clamp must be oriented as shown to avoid fender or engine guard contact with clutch cable adjuster cover.

7. See Figure 4. Position the clamp (2) from the kit onto the clutch cable just above the clutch cable adjuster cover (3) in the orientation shown. Fasten the clamp to the frame downtube (1) with the TORX® screw (4) from the kit.

If there is no cable strap fastening the clutch cable to the frame downtube just below the adjuster:

- Use the cable strap (5) from the kit to fasten the cable about 2 inches (51 mm) below the clutch cable adjuster cover, OR
- Install a Billet Chrome Cable Clamp Kit, part number 91147-02 (available separately), directly beneath the cover (see Figure 5) per the instructions in that kit. Proceed to Step 8.

is04333

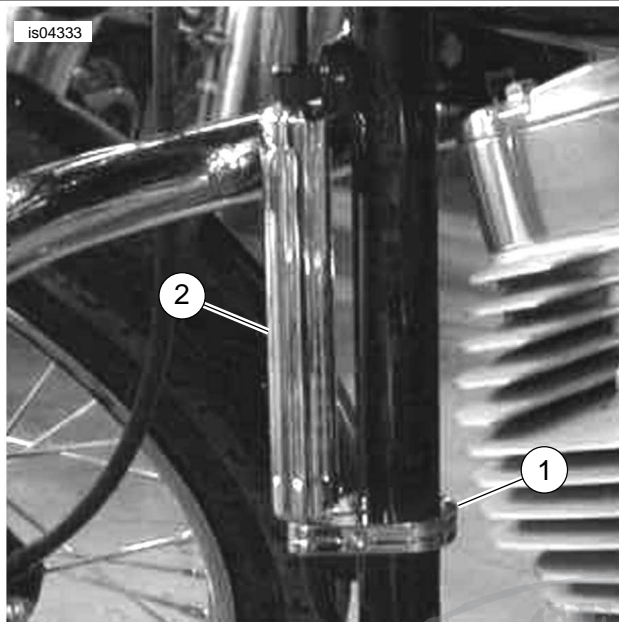

1. Cable Strap or Optional Billet Cable Clamp (Shown)
2. Clutch Cable Adjuster Cover

Figure 5. Lower Clamp Position, Softails (Optional Billet Clamp Kit Shown)

All Models

8. Verify that there is sufficient clearance to the clutch cable adjuster cover and that clutch lever operates freely at all positions from full left to full right steering stop. Check that cover does not strike frame downtube during vehicle operation.

WARNING

After relocating clutch cable, check that clutch hand lever opens and closes smoothly when handlebars are turned fully left or right. Slow clutch lever response could result in loss of control and death or serious injury (00424d)

