



INSTRUCTIONS

-J01923

2006-10-04

BRAIDED STAINLESS STEEL FUEL CROSSOVER LINE KIT

GENERAL

Kit Numbers

63690-00A, 63692-00A, 63694-00A, 63696-00A, 63709-04, 63729-04.

Models

For model fitment information, please see the P&A Retail Catalog or the Parts and Accessories section of www.harley-davidson.com (English only).

Additional Parts, Tools and Service Manual Required

Carbureted models will require use of a vacuum pump (Plastic Mity-Vac[®] hand pump, part number HD-23738-A or equivalent) and hose clamp pliers (part number HD-97087-65B or equivalent).

Carbureted models will also require separate purchase of a fuel hose clamp (Part Number 10014), available from a Harley-Davidson Dealer.

⚠ WARNING

The rider's safety depends upon the correct installation of this kit. Use the appropriate service manual procedures. If the procedure is not within your capabilities or you do not have the correct tools, have a Harley-Davidson dealer perform the installation. Improper installation of this kit could result in death or serious injury. (00333a)

NOTE

This instruction sheet references Service Manual information. A Service Manual for your model motorcycle is required for this installation and is available from a Harley-Davidson Dealer.

Kit Contents

See Figure 3 and Table 1.

INSTALLATION, CARBURETED MODELS

Models WITH maxi-fuse:

⚠ WARNING

To prevent accidental vehicle start-up, which could cause death or serious injury, remove main fuse before proceeding. (00251b)

1. Refer to the Service Manual and follow the instructions given to remove the maxi-fuse.

Models WITHOUT maxi-fuse:

⚠ WARNING

To prevent accidental vehicle start-up, which could cause death or serious injury, disconnect negative (-) battery cable before proceeding. (00048a)

1. Refer to the Service Manual and follow the instructions given to remove the seat and disconnect the negative (black) battery cable from the negative (-) battery terminal. Retain all seat mounting hardware.

ALL carbureted models

⚠ WARNING

When servicing the fuel system, do not smoke or allow open flame or sparks in the vicinity. Gasoline is extremely flammable and highly explosive, which could result in death or serious injury. (00330a)

2. See FUEL SUPPLY VALVE FILTER: CARBURETED in the Service Manual.
 - a. Turn the fuel supply valve to the OFF (horizontal) position.
 - b. Follow the instructions to disconnect the fuel hose from the fuel supply valve outlet nipple. Drain the fuel from the fuel tank into an adequately sized, approved gasoline container using a vacuum pump (Plastic Mity-Vac hand pump or equivalent).
 - c. Re-install the fuel hose to the fuel supply valve with a new fuel hose clamp (Part Number 10014), purchased separately.
 - d. Proceed to Step 3.

INSTALLATION, EFI MODELS

⚠ WARNING

When servicing the fuel system, do not smoke or allow open flame or sparks in the vicinity. Gasoline is extremely flammable and highly explosive, which could result in death or serious injury. (00330a)

Models WITH maxi-fuse:

1. See FUEL TANK: EFI in the Service Manual, and follow the instructions to purge the fuel line of high pressure gasoline.

⚠ WARNING

To prevent accidental vehicle start-up, which could cause death or serious injury, remove main fuse before proceeding. (00251b)

2. Refer to the Service Manual and follow the instructions given to remove the maxi-fuse. Proceed to Step 3.

Models WITHOUT maxi-fuse:

-J01923



Many Harley-Davidson[®] Parts & Accessories are made of plastics and metals which can be recycled. Please dispose of materials responsibly.

1 / 3

1. See FUEL TANK: EFI in the Service Manual, and follow the instructions to purge the fuel line of high pressure gasoline.

▲ WARNING

To prevent accidental vehicle start-up, which could cause death or serious injury, disconnect negative (-) battery cable before proceeding. (00048a)

2. Refer to the Service Manual and follow the instructions given to remove the seat and disconnect the negative (black) battery cable from the negative (-) battery terminal. Retain all seat mounting hardware. Proceed to Step 3.

INSTALLATION (CONTINUED), ALL MODELS

1. Remove the existing fuel crossover hose from both fittings under the fuel tank. Make note of the hose routing to aid in the installation of the new line.
2. Slide a nut (with the threads facing out) from the kit over each one of the fuel tank fittings.
3. Install a rubber seal from the kit to each of the fittings.
4. For ALL models **except 1986 through 1999 Softails:** See Figure 1. Following the same routing as the original crossover hose, install the braided line from the kit to each of the nuts. **For 1986 through 1999 Softail models:** See Figure 2. Route the braided crossover line through the opening in the frame at the inboard side of the frame downtubes as shown.

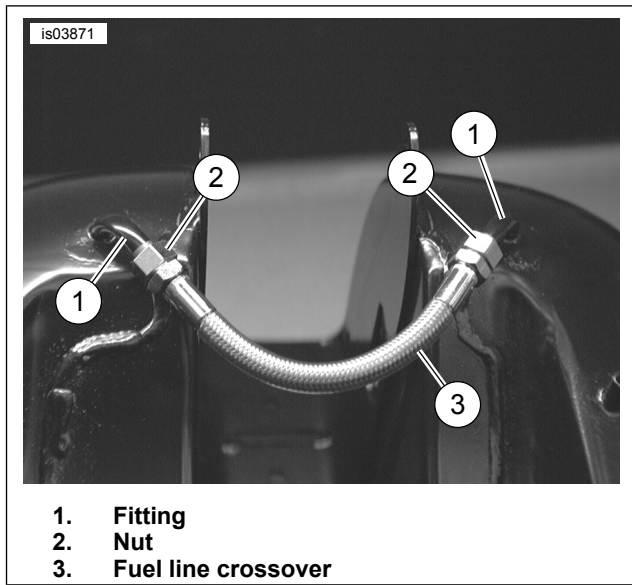

Figure 1. Install Braided Line (Typical) (Tank removed for illustration purposes only)

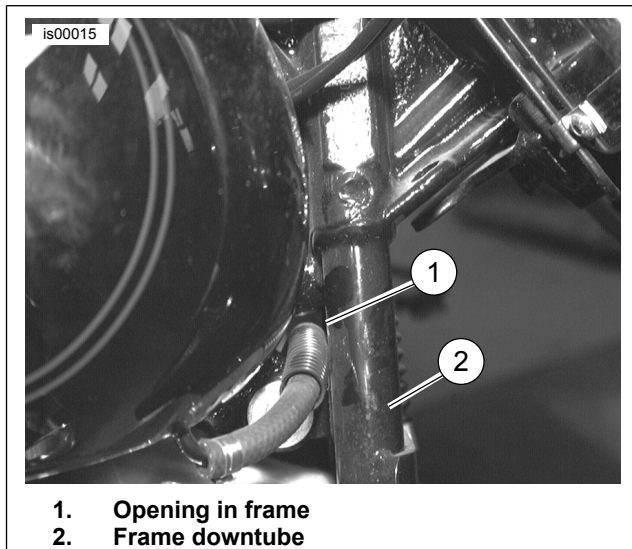

Figure 2. Fuel Line Routing (1986 to 1999 Softail Models Only)

5. Tighten each of the nuts until the threads bottom out, making sure the seal does not extrude between the nut and fitting.
6. Fill the tank with fuel, and check all connections for leaks.

SERVICE PARTS

is00016

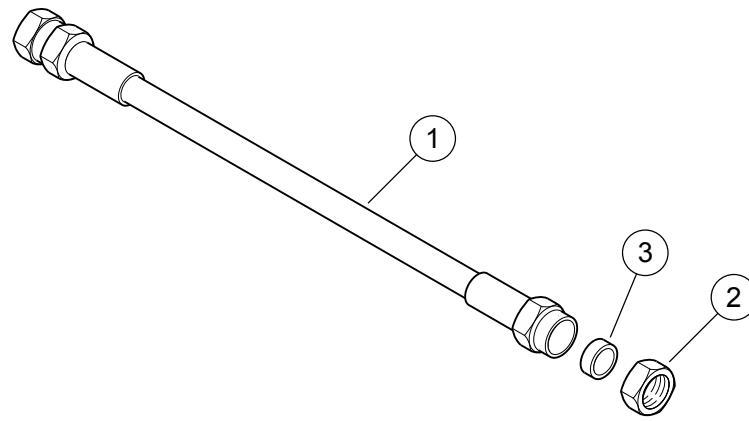

Figure 3. Service Parts (-J01923)

Table 1. Service Parts (-J01923)

Item	Description (Quantity)	Part Number	
1	Hose (Length and fitting type may vary by kit number)	Not sold separately	
2	Nut (2)	Not sold separately	
3	Seal (4)	for kit 63690-00A	63784-00
		for kit 63692-00A	63785-00
		for kit 63694-00A	63785-00
		for kit 63696-00A	63784-00
		for kit 63709-04	63784-00
		for kit 63729-04	63784-00