



INSTRUCTIONS

-J05661

2013-04-20

XL PREMIUM OIL COOLER KIT

GENERAL

Kit Number

62700082

Models

For model fitment information, see the P&A Retail Catalog or the Parts and Accessories section of www.harley-davidson.com (English only).

Additional Parts Required

Proper installation of this kit requires the following items:

- Hylomar® Gasket and Thread Sealant
- Loctite® 243 Threadlocker and Sealant (Part No. 99642-97)
- Oil Filter Wrench (Part No. 42311) or (Part No. 44067-A)
- Loctite 565 High Performance Pipe Sealant with Teflon

⚠ WARNING

The rider's safety depends upon the correct installation of this kit. Use the appropriate service manual procedures. If the procedure is not within your capabilities or you do not have the correct tools, have a Harley-Davidson dealer perform the installation. Improper installation of this kit could result in death or serious injury. (00333a)

NOTE

This instruction sheet references service manual information. A service manual for your model motorcycle is required for this installation and is available from a Harley-Davidson dealer.

Kit Contents

See Figure 6 and Table 1.

REMOVE

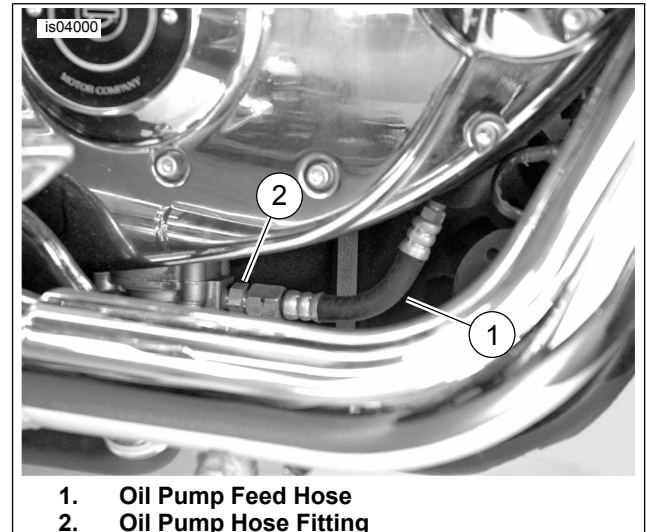

1. Oil Pump Feed Hose
2. Oil Pump Hose Fitting

Figure 1. Oil Pump Feed Hose

1. See the service manual. Drain engine oil.
2. See the service manual. Remove the oil filter.
3. See the service manual. Remove exhaust system.
4. See the service manual. Remove oil pressure switch.
5. See Figure 1. Remove oil feed hose (1) from oil pump.
6. Remove and discard the oil pump hose fitting (2) from the oil pump.
7. **ABS Models:** See Figure 5. Remove the upper ABS brake line clamp (22) from the left down tube.
8. Remove two clips securing the clutch cable and wiring harness to the downtube.

INSTALLATION

1. See the service manual. Install oil pressure switch in the same manner as indicated, but in the location indicated below.
 - a. Apply Loctite 565 High Performance Pipe Sealant with Teflon to oil pressure switch.
 - b. See Figure 2. Install oil pressure switch (3) to **crankcase** where the feed hose was connected.
 - c. Tighten to 5.6–7.9 N·m (50–70 in-lbs).
2. Install jumper wire assembly (item 2, Figure 6) to oil pressure switch lead.
 - a. Cut the existing oil pressure connector off the wiring harness. Cut close to the connector.



- b. Measure the amount of wire necessary for the connector of the wire assembly to reach the oil pressure switch. Cut the wire to length.
 - c. Strip 10 mm ($\frac{3}{8}$ in) of insulation from the lead.
 - d. Measure the amount of conduit (item 19, Figure 6) necessary to cover the wire assembly. Cut the conduit to length.
 - e. Install conduit over the wire assembly.
 - f. See the service manual sealed splice connector installation instructions. Install the new oil pressure switch connector to the harness lead with the sealed splice connector (item 13, Figure 6).
3. Connect oil pressure switch connector to the oil pressure switch.
 4. See Figure 2. Apply Hylomar Gasket and Thread Sealant to fitting (item 11, Figure 6). Install fitting to oil pump. Tighten fitting to 6.2–7.4 N·m (55–65 in-lbs).
 5. Loosely install oil cooler supply hose assembly (2) to oil pump fitting.
 6. Apply Hylomar Gasket and Thread Sealant to fitting (item 16, Figure 6). Install fitting to original oil pressure switch mounting location. Tighten finger-tight, then turn 2-3 times more. Orient the fitting opening to be in line with the oil filter housing.
 7. Apply Hylomar Gasket and Thread Sealant to fitting (item 12, Figure 6). Install fitting to the elbow fitting. Tighten finger-tight, then turn 2-3 times more. Orient the fitting to be in line with the oil filter housing.

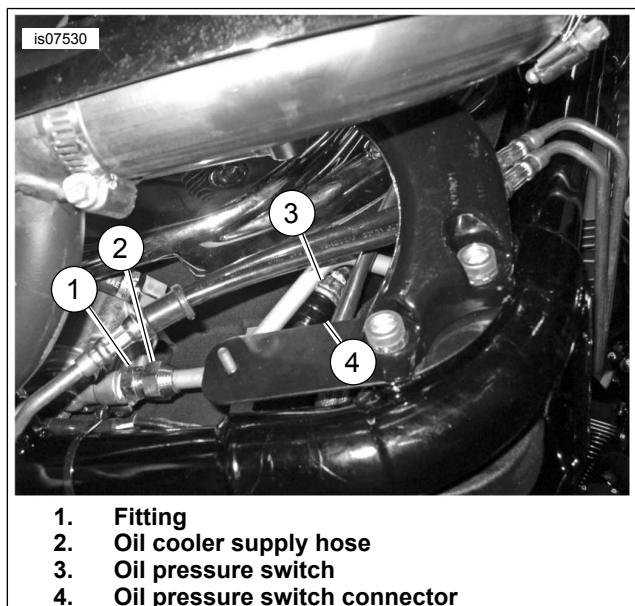

Figure 2. Oil Supply Line and Oil Pressure Switch

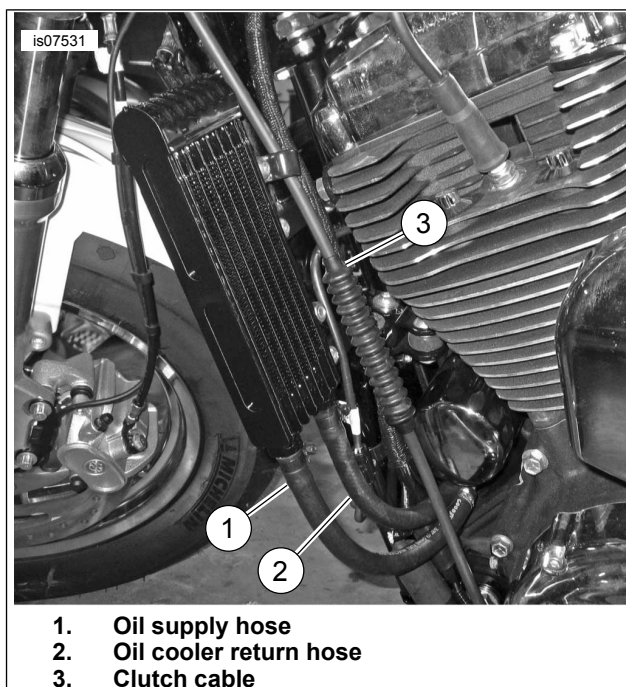

Figure 3. Oil Cooler Hose Routing

8. See Figure 5. Install the brake line grommets (1) onto the ABS brake lines along the downtube.
9. Install the oil cooler clamps (2) over the brake line grommets. Adjust the locations as necessary to match the oil cooler mounting tab spacing and desired oil cooler mounting location. Locate top clamp below the bend in the ABS brake lines (21).

NOTE

See Figure 3. When installing the oil cooler and connecting the oil lines, make sure that the clutch is routed properly.

10. See Figure 5. Orient mounting bar (7) as shown with the rounded end up and the first and third holes outboard. Install mounting bar (7) to oil cooler clamps and secure with screw (3) and nut (4). Do not tighten fasteners. Repeat for other oil cooler clamp.
11. Install P-clamp (19) over the clutch cable and wiring harness.
12. Loosely attach oil cooler (10) to the mounting bar (7) upper hole using screw (5), washer (6), P-clamp (19) and nut (4).
13. Loosely attach oil cooler (10) to the mounting bar (7) lower hole using screw (5), washers (6) and nut (4).
14. Connect oil return hose (14) to the inboard connection of oil cooler (10) with worm clamp (15).
15. Connect oil return hose (14) to hose fitting (16) with worm clamp (15).
16. Connect oil cooler supply hose (8) to the outboard connection of oil cooler (10) with worm clamp (15). Orient hose to allow clearance between oil pressure switch and oil cooler return hose.
17. Tighten worm clamps to 0.9 N·m (8 in-lbs).

18. Adjust oil cooler.

- a. Adjust oil cooler as necessary to have it facing forward.
- b. Adjust oil cooler height if necessary so there is no tension on the oil cooler hoses.
- c. Remove screws, one at a time (to maintain clamp location). Apply Loctite 243 Threadlocker and sealant (blue) to threads. Install screws to clamp clamps.

NOTE

See Figure 4. Make sure that oil cooler supply hose (2) does not rub against the oil pressure switch (1).

19. Tighten oil cooler clamp screws to 10.2–13.5 N·m (96–120 in-lbs).

20. Tighten oil cooler supply hose at oil pump fitting to 24.4–27.1 N·m (18–20 ft-lbs). Hold the tube in place, while tightening.

21. See Figure 5. Install cable strap (20) around frame and wire harness in area shown. Tighten cable strap so all wires are pulled toward the outside of the frame rail.

22. Install previously removed ABS brake line clamps.

NOTE

Make sure no part of the cooler cover contacts the wiring harness or cables.

23. Inspect oil lines and hoses. Make sure that there is no contact with the wiring harness or cables.

24. See the instructions included with the oil cooler cover. Install oil cooler cover onto the oil cooler.

25. After tightening the oil cooler clamp screws, inspect to make sure that there is enough clearance between the oil cooler cover and the wiring harness to prevent rubbing or chafing.

26. See the service manual Install exhaust system.

27. See the service manual. Install oil filter and add oil.

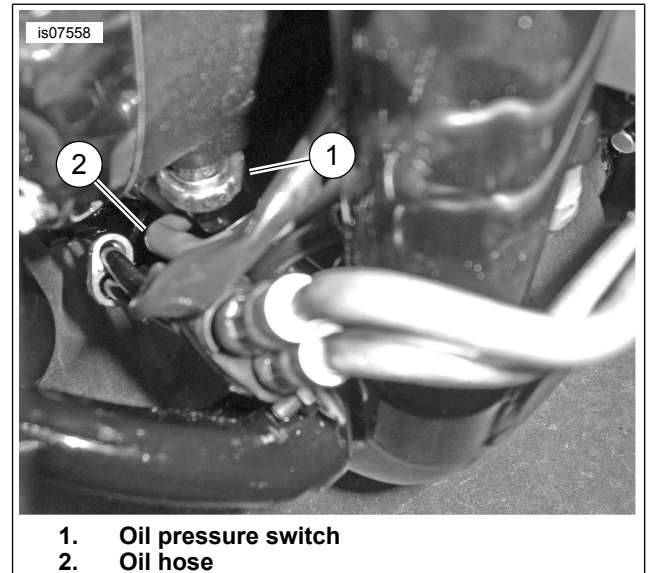

Figure 4. Oil Pressure Switch and Oil Hose

SYSTEM FLOW TEST

NOTICE

Do not operate the engine when the oil level is below the add mark on the dipstick at operating temperature. Engine damage will result. (00187b)

1. Inspect hoses for kinks or twists. Adjust hoses as necessary to remove kinks or twists.
2. Start engine. Inspect all hose connections for leaks. If there is no leakage, allow engine to warm up.
3. Verify that temperature of oil cooler increases when engine reaches normal operating temperatures. If the oil cooler remains cool after engine has warmed up, there may be an oil obstruction. Turn off engine and check system for source of obstruction.
4. After engine has cooled, retighten all fittings and clamps to the required torque specifications.
5. Fill oil to "Full" level on dipstick if necessary.

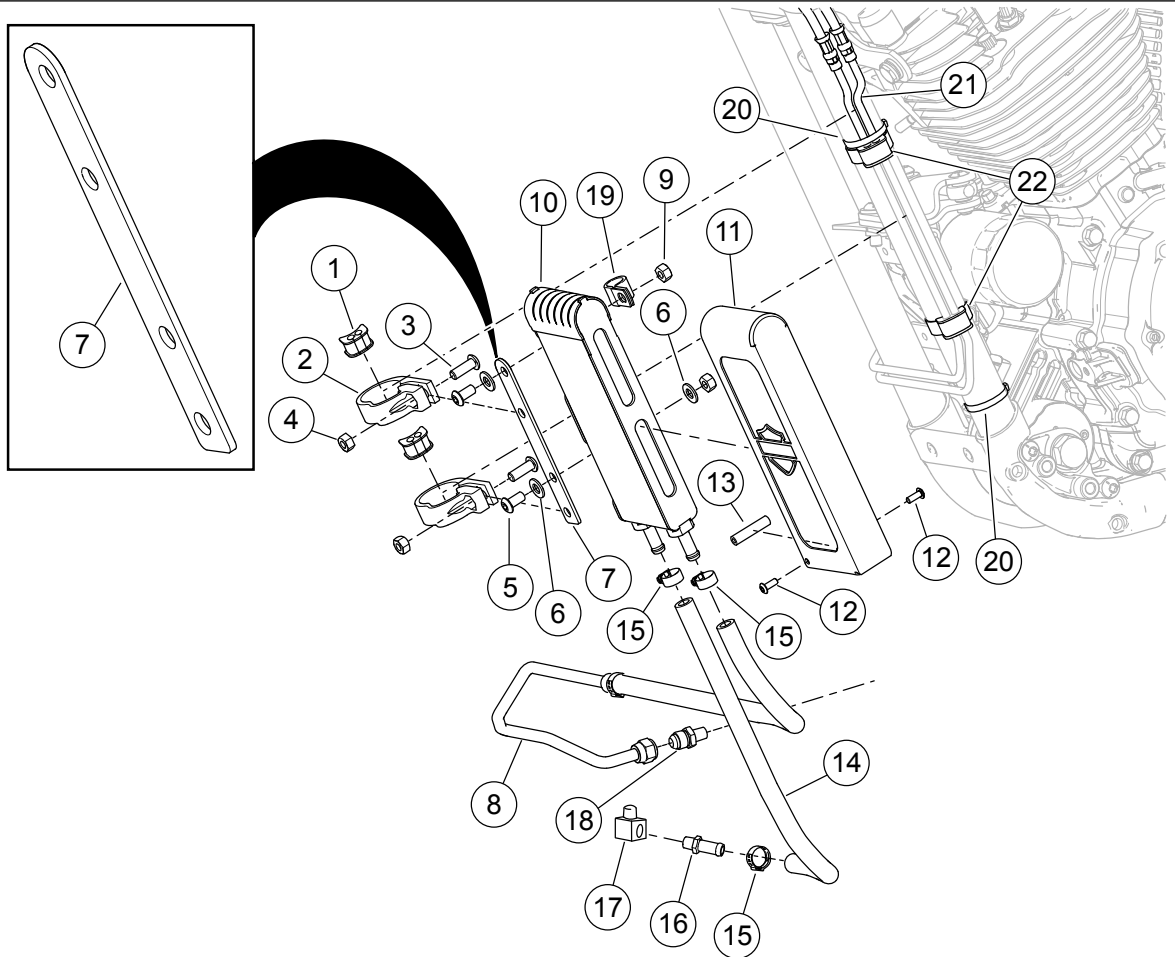

- | | |
|---------------------------|-----------------------------|
| 1. Grommet (2) | 12. Screw (2) |
| 2. Oil cooler clamp (2) | 13. Spacer tube |
| 3. Screw (2) | 14. Oil cooler return hose |
| 4. Nut (2) | 15. Worm clamp (3) |
| 5. Screw (2) | 16. Hose fitting |
| 6. Flat washer (2) | 17. Elbow fitting |
| 7. Mounting bar | 18. Line fitting |
| 8. Oil cooler supply hose | 19. P-clamp |
| 9. Nut (2) | 20. Cable strap |
| 10. Oil cooler | 21. Bend in ABS brake lines |
| 11. Oil cooler cover | 22. ABS brake line clamp |

Figure 5. Oil Cooler Installation

SERVICE PARTS

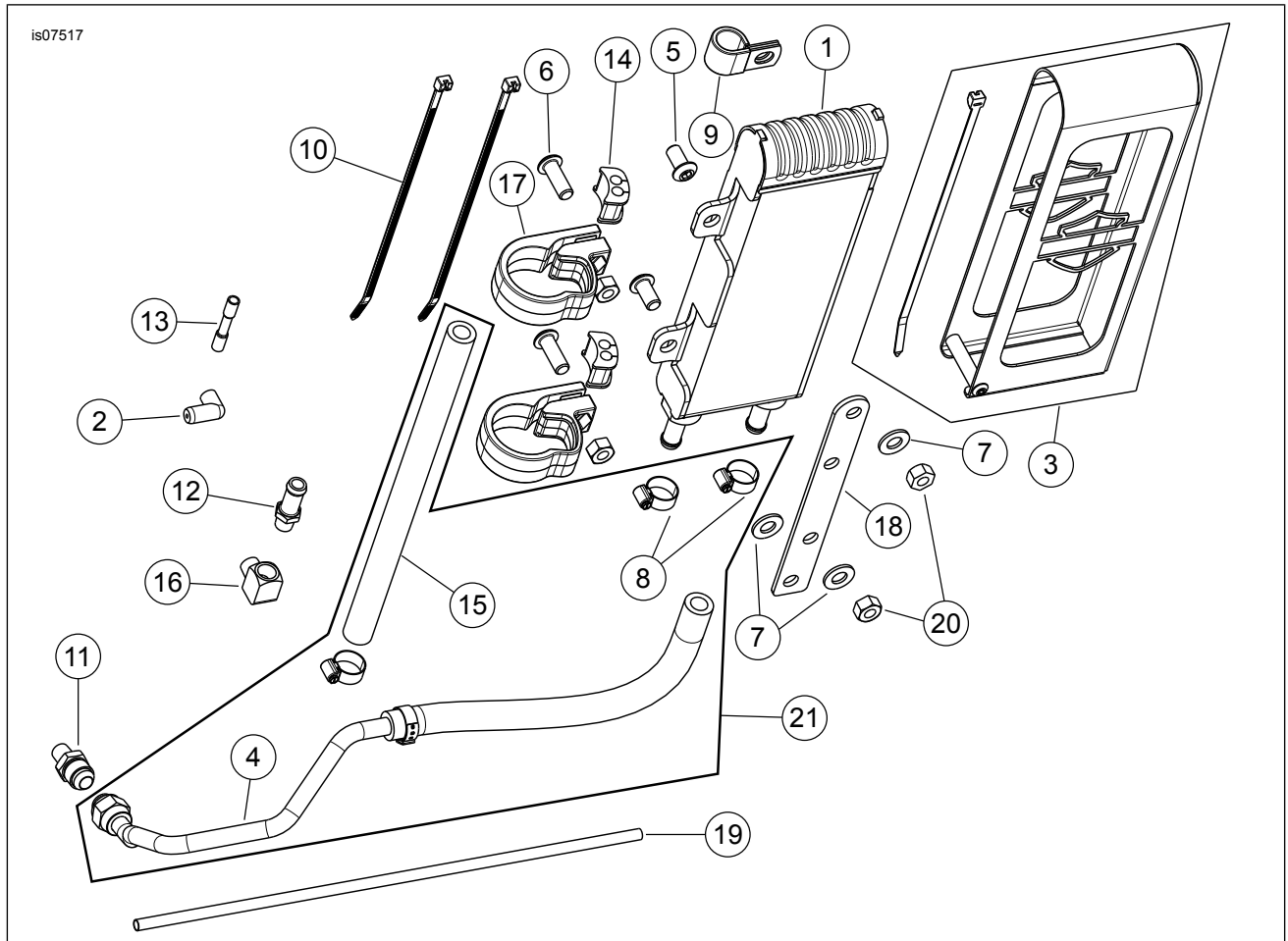

Figure 6. Service Parts: XL Premium Oil Cooler Kit

Table 1. Service Parts Table

Item	Description (Quantity)	Part Number
1	Cooler, oil	63094-07
2	Right angle connector and wire	72405-98GN
3	Oil cooler cover kit	62500024
4	Hose, oil cooler supply	Not Sold Separately
5	Screw (2)	3540
6	Screw (2)	4359
7	Washers (3)	6330
8	Clamp, worm drive #4 (3)	9823
9	P-clamp	10076
10	Cable strap (2)	10246
11	Fitting	63091-07
12	Fitting	63533-41A
13	Sealed splice connector, 18-22 AWG	70585-93
14	Grommet, brake line	Not Sold Separately
15	Hose, oil cooler return	Not Sold Separately
16	Fitting, elbow, 90 degree	62700080
17	Clamp, oil cooler (2)	62800016
18	Mounting bar, oil cooler	Not Sold Separately
19	Conduit, high temperature	Not Sold Separately
20	Nut, hex (4)	7748W
21	Service kit, oil hose (Includes items 4, 15 and 8)	62700078