



INSTRUCTIONS

-J05130

2010-10-19

CHROME TAPPET BLOCK ACCENT KIT

GENERAL

Kit Number

61400002

Models

For model fitment information, see the P&A retail catalog or the Parts and Accessories section of www.harley-davidson.com (English only).

Kit Contents

Table 1. Kit Contents

Item	Description (Quantity)
1	Tappet block accent, chrome
2	Bracket
3	Screw, hex socket button head, #10-24 x 9.5 mm (3/8 in) long
4	Sleeve, hollow point (8)
5	Cover, bolt head, 6.4 mm (1/4 in) (8)

There are no service parts available for this kit.

INSTALLATION

NOTE

- Ambient temperature should be **at least** 16 °C (60 °F) for proper adhesion of the chrome accent to the engine crankcase.
- Test-fit the chrome accent to the engine crankcase before installation. Do not remove the liners until ready to permanently apply the accent.

1. See Figure 1. Remove the two inboard socket head lifter cover (tappet block) screws (6) and set aside.
2. Position the bracket (2) in the area between the engine cylinders as shown, aligning the two slots in the bracket with the threaded holes in the lifter cover. Loosely install the screws (6) through the slots and into the lifter cover.
3. Use a clean shop rag and soapy water to remove any grease or debris from the area of the engine crankcase where the chrome accent will mount. Allow the area to dry.
4. Thoroughly clean the area in front of the lifter cover, using isopropyl alcohol or an alcohol wipe, and allow the area to dry completely.
5. On the underside of the chrome accent (1), use a fingernail to rub the liners of the adhesive backing to activate the adhesive. Peel all the liners from the adhesive backing of the chrome accent.

6. Carefully position the accent to the crankcase and lifter cover, and insert the #10-24 screw (3) through the accent and into the threaded hole in the bracket. Do not fully tighten.
7. Press the accent firmly into position. Hold in place with steady pressure for about one minute. Allow AT LEAST 24 hours after applying the accent before exposing the area to vigorous washing, strong water spray or extreme weather.
8. Tighten the #10-24 screw securely.
9. Tighten the two inboard socket head tappet block screws (6) to 10.2–13.6 N·m (90–120 in-lbs).
10. Push a hollow point sleeve (4) fully down over the head of each of the eight tappet block screws. Push a decorative bolt head cover (5) into the hex socket of each screw.

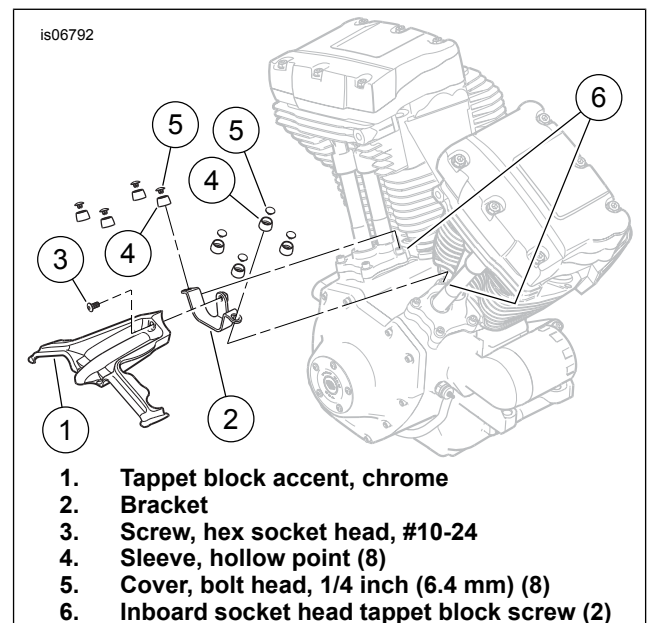

Figure 1. Twin Cam Tappet Block Accent Installation

