



INSTRUCTIONS

-J03940

REV. 2011-05-15

AIR CLEANER TRIM KIT

GENERAL

Kit Numbers

27929-08, 27935-08, 27936-08, 27937-08, 27938-08, 27939-08, 27958-10, 61300056

Models

For model fitment information, see the P&A Retail Catalog or the Parts and Accessories section of www.harley-davidson.com (English only).

Tools and Supplies Required

Loctite® 243 (Blue) Threadlocker and Sealant (Part Number 99642-97) is required for the proper installation of this kit.

Kit Contents

See Figure 1 and Table 1.

INSTALLATION

1. See Figure 1. Remove and discard the original air cleaner cover screw.
2. Remove and discard the original air cleaner trim ring from the front of the air cleaner cover. Any adhesive that remains on the air cleaner cover can be removed with mineral spirits.
3. Apply a drop of Loctite® 243 (blue) to the threads of screw (4).
Use the screw to install the new air cleaner insert mounting disk (1), with the two outer holes (A) aligned at the 3 o'clock and 9 o'clock position as shown.
Tighten the screw to **36-60 in-lbs** (4.1-6.8 Nm).
4. Place the new air cleaner insert (2) over the insert mounting disk, aligning with the two mounting holes.
5. Secure the insert cover to the backplate with the two **new** button head screws (3) from the kit, and tighten to **16-20 in-lbs** (1.8-2.3 Nm).

SERVICE PARTS

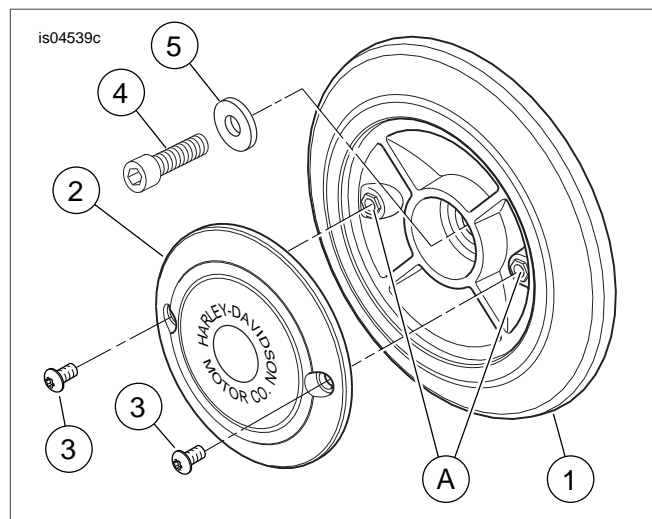

Figure 1. Service Parts: Air Cleaner Trim Kit

Table 1. Service Parts: Air Cleaner Trim Kit

Item	Description (Quantity)	Part Number
1	Mounting disk, air cleaner insert	Not sold separately
2	Insert, air cleaner	Not sold separately
3	TORX® screw, #8-32, with lockpatch (2)	4854
4	Screw	3494A
5	Washer	6333
Items mentioned in text, but not included in kit.		
A	Outer holes (align at 3 o'clock and 9 o'clock position)	

