



INSTRUCTIONS

-J03314

REV. 2010-08-02

AIR CLEANER COVER INSERT

GENERAL

Kit Number

29416-04, 27957-10, 27961-10

Models

For model fitment information, see the P&A Retail Catalog or the Parts and Accessories section of www.harley-davidson.com (English only).

NOTE

A service manual for your model motorcycle is available from your Harley-Davidson Dealer.

Kit Contents

See Figure 2 and Table 1.

INSTALLATION

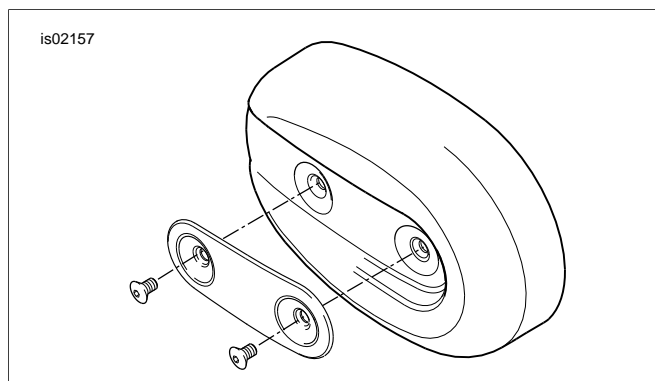

Figure 1. Existing Screws and Insert

1. See Figure 1. Remove existing screws and insert from front of air cleaner cover.
2. See Figure 2. Match the holes and place the kit insert (1) on the front of the air cleaner cover.

3. Install the insert with screws (2) or (3) and washers (4).

NOTE

The longer screws (2) are installed when using the Screamin' Eagle Sportster High-Flow Air Cleaner Kit (Harley-Davidson Part No. 29042-04). The shorter screws (3) are installed with the stock air cleaner assembly.

4. Tighten screws to 30-60 **in-lbs** (4.1-6.8 Nm).

SERVICE PARTS

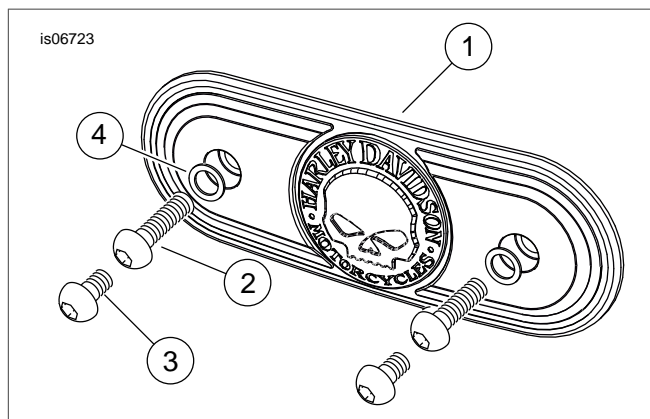

Figure 2. Service Parts "Skull" Air Cleaner Insert Shown

Table 1. Service Parts: "Skull" Air Cleaner Insert

Item	Description (Quantity)	Part Number
1	Air cleaner insert	Not Sold Separately
2	Screw (2)	94334-91T
3	Screw (2)	94331-91T
4	Washer (2)	Not Sold Separately

