



INSTRUCTIONS

-J00564

REV. 3-03-03

Kit Number 60050-01, 60051-01, and 60065-03

LICENSE PLATE FRAME KIT

General

60050-01 Harley-Davidson License Plate Frame Kit fits license plates measuring a maximum of 8-1/2 in. by 4-3/4 in. (21.6 cm x 12.1 cm).

60051-01 Harley-Davidson License Plate Frame Kit fits license plates measuring a maximum of 7-1/4 in. by 4-1/4 in. (18.4 cm x 10.8 cm).

60065-03 USA License Plate Frame Kit fits license plates measuring a maximum of 7/1/4 in. by 4-1/4 in. (18.4 cm x 10.8 cm).

This kit is designed to be used on all motorcycle models except those equipped with a Layback License Plate Mounting Kit accessory.

See the Service Parts illustration in this instruction sheet for a list of items contained in this kit.

Installation

1. Remove and discard the screws and nuts fastening the license plate to the bracket.
2. Place the License Plate Frame on the bracket, aligning the bottom screw holes of the frame to the bottom screw holes of the stock bracket. Use screws to align the holes. If the bottom of the License Plate Frame covers any part of the reflector on the bottom of the stock bracket, go to step 2a. Otherwise, go to step 3.
 - a. Remove the existing reflector.
 - b. Remove the residual reflector adhesive from the bracket using isopropyl alcohol.

NOTE

The stock-bracket surface must be clean and free of dust, dirt, and adhesive material for proper installation and adhesion of the replacement reflector.

3. Assemble the license plate, frame, and hardware as shown in the Service Parts illustration, with the following notes:
 - On **FX Softail and FXDWG models** with stock bracket, fasten the bottom of the License Plate Frame to the stock bracket, but do not tighten. Go to step 4.
 - For **FX Softail & FXDWG models** with License Plate Bracket Cover 59720-01A, fasten the bottom of the License Plate Frame and license plate to the cover and bracket. Tighten the fasteners to 10 **in-lbs** (0.1 Nm). Go to step 5.

- **All other installations**, fasten the bottom of the frame and license plate to the stock bracket. Tighten the fasteners to 10 **in-lbs** (0.1 Nm). Go to step 5.

CAUTION

Do not over-tighten the License Plate Frame fasteners. Applying too much torque to the License Plate Frame fasteners may damage the License Plate Frame.

CAUTION

Do not drill the stock bracket without a block of wood between the rear tire and the stock bracket. Drilling the bracket without a block of wood in place may cause damage to the rear tire.

4. Place a block of wood between the rear tire and the stock bracket.
 - a. Use the license plate frame as a template to mark the frame's two upper mounting locations on the stock bracket. Remove the frame from the bracket.
 - b. Drill a 1/16-in. pilot hole through the stock bracket at each of the two upper mounting locations.
 - c. Enlarge the pilot holes using a 9/32-in. drill bit.
 - d. Remove the block of wood.
 - e. Fasten the License Plate Frame and license plate to the stock bracket with the hardware as shown in the Service Parts illustration. Tighten all the fasteners to 10 **in-lbs** (0.1 Nm).
5. On models that required removing the stock reflector:
 - a. Remove the adhesive-strip cover from the back of the replacement reflector.
 - b. Position the upper edge of the replacement reflector against the bottom edge of the License Plate Frame and press the adhesive backing firmly to the stock bracket. If the reflector does not fit below the License Plate Frame, then install the reflector on the bottom of the License Plate Frame.

NOTE

Firmly rub the replacement reflector, applying sufficient pressure to the reflector to ensure a strong adhesive bond to the stock bracket.



Service Parts

Part No. 60050-01*

Date 3/03

License Plate Frame Kit

FX Softail and FXDWG Models with License Plate Bracket Cover Kit 59720-01A

i02340

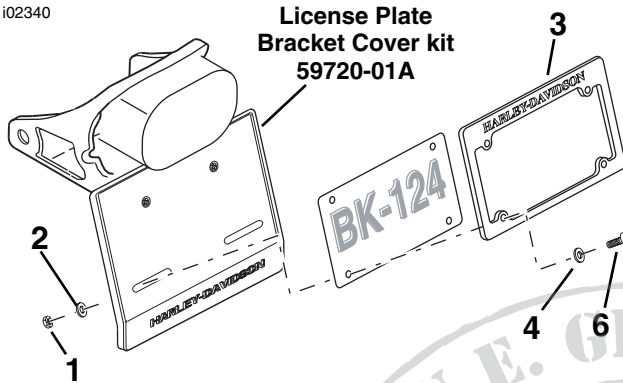

FX Softail and FXDWG Models

i02339a

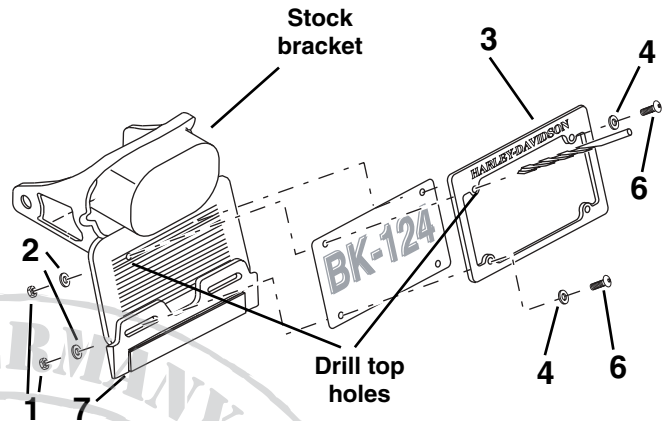

Standard Touring Model

i02336

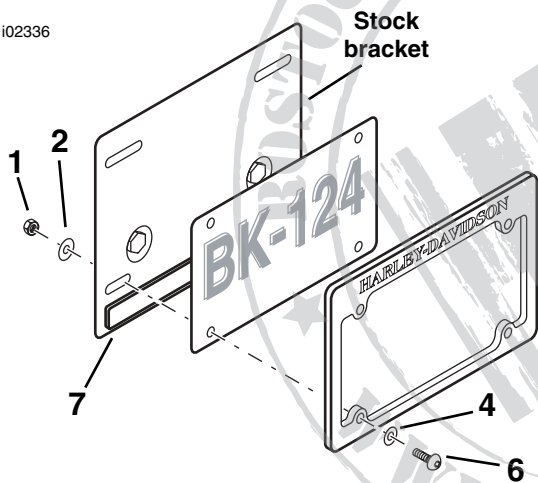

Three-Point Plate Bracket

i02338

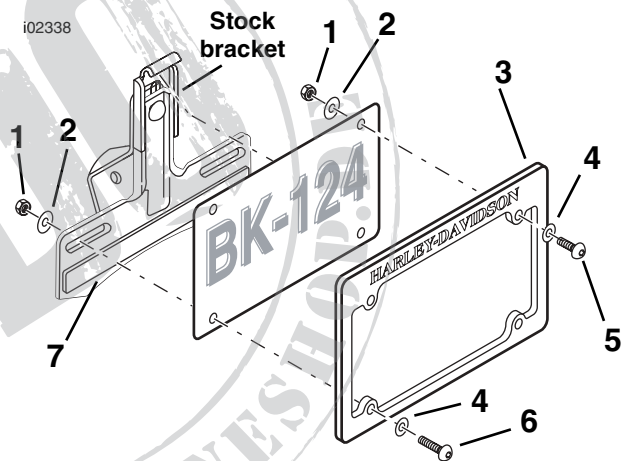

Item	Description	Part Number	Equivalent Chrome-Plated Part Number
1	Nut, Nyloc, 1/4-20 (4)	Not Sold Separately	94026-92T
2	Washer, Flat, 1/4-in. Large O.D. (4)	Not Sold Separately	94065-90T
3	Frame, License Plate	Not Sold Separately	-
4	Washer, Flat, 1/4-in. Small O.D. (4)	Not Sold Separately	-
5	Screw, 1/4-20 x 3/4-in. Button Head (2)	Not Sold Separately	94386-92T
6	Screw, 1/4-20 x 1-in. Button Head (4)	Not Sold Separately	94388-92T
7	Reflector (1)	59988-72A	-

*60050-01, 60051-01, and 60065-03 are similar in design.