



INSTRUCTIONS

-J02381

REV. 2011-03-10

SHOR'TEE BELT GUARD

GENERAL

Kit Number

60610-02A, 60610-07, 60649-07, 60490-08, 60300004

Models

For model fitment information, see the P&A Retail Catalog or the Parts and Accessories section of www.harley-davidson.com (English only).

Additional Parts Required

NOTE

A Service Manual for your model motorcycle is available from your Harley-Davidson dealer.

Loctite® 243 Threadlocker and Sealant - Blue, Harley-Davidson Part Number 99642-97, is available from a Harley-Davidson Dealer.

Kit Contents

See Figure 3, Figure 4 and Table 1.

INSTALLATION

Stock Belt Guard Removal

1. Remove the left-side saddlebag, if equipped.
2. See Figure 1 and Figure 2. Remove the acorn nut and set screw (2) from the tee nut (7). For installation, note how the rubber-grommet is inserted through the tab on the belt guard.
3. Remove the screw (6), washer (5), and acorn nut (3).
4. Discard all hardware removed.

New Belt Guard Installation

1. **For 2007 and Earlier Models:** Refer to Figure 3.
For 2008 Models: Refer to Figure 4.
Position the front-upper belt guard and rear-upper belt guard as shown.
2. Loosely fasten the front and rear belt guards together using the chrome capscrew (1).
3. Apply Loctite 243 (blue) to the threads on the end of the set screw (8).
4. Fasten the set screw to cap nut (9). Tighten the nut and screw to 60-96 **in-lbs** (6.8-11 Nm).
5. Insert the rubber grommet (6) through the rear tab on the rear-upper belt guard (7).
6. Press the tee nut (5) into the rubber grommet.

7. Position the rear-upper belt guard on the vehicle, with the belt guard's front tab on the inboard side of the debris deflector.

NOTE

Belt guard contact with the drive belt will result in drive-belt damage. Adjust the belt guard to avoid damage.

8. Before securing the belt guard to the motorcycle, adjust the belt guard to prevent it from contacting the drive belt.
9. **For Kit 60490-08 & 60300004:** Tighten the chrome capscrew (1) to 22 **in-lbs** (2.4 Nm).
10. Securely fasten the cap nut and set screw through the outboard side of the swingarm tab and into the tee nut on the belt guard's rear tab.
11. Fasten the belt guard's front tab to the vehicle using the screw (4), washers (3), and cap nut (9) as shown. Tighten the nut to 60-96 **in-lbs** (6.8-11 Nm).
12. **For Kits 6061002A, 60610-07 and 60649-07:** Tighten the chrome capscrew (1) to 22 **in-lbs** (2.4 Nm).
13. Install the left saddlebag, if equipped.



is02029

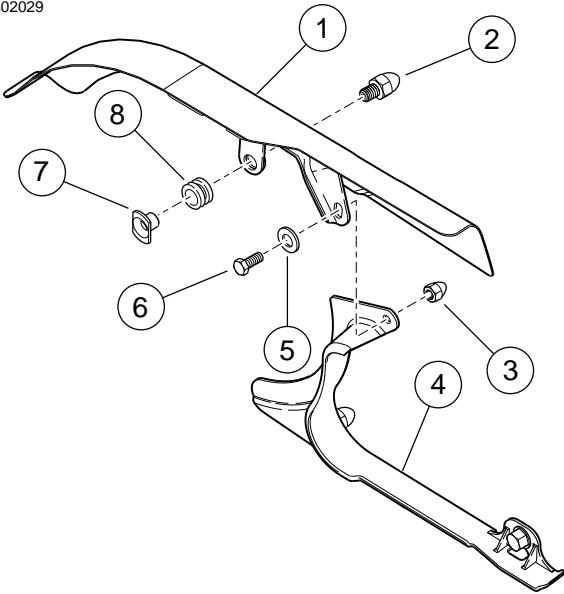

- 1. Belt guard
- 2. Acorn nut and set screw
- 3. Acorn nut
- 4. Debris deflector
- 5. Washer
- 6. Screw
- 7. Tee nut
- 8. Rubber grommet

Figure 1. All Models except 2008 FXCW and FXCWC: Stock Belt Guard

is04634

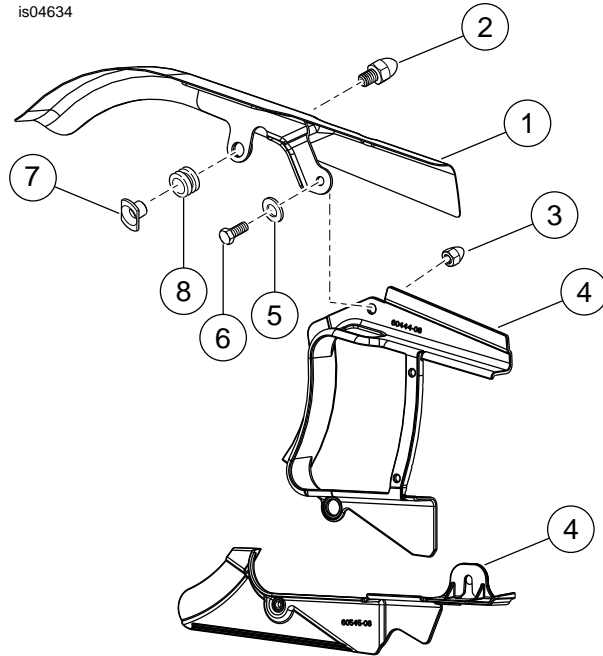

- 1. Belt guard
- 2. Acorn nut and set screw
- 3. Acorn nut
- 4. Debris deflector
- 5. Washer
- 6. Screw
- 7. Tee nut
- 8. Rubber grommet

Figure 2. 2008 Softtail FXCW and FXCWC Models Only: Stock Belt Guard



SERVICE PARTS

is02030

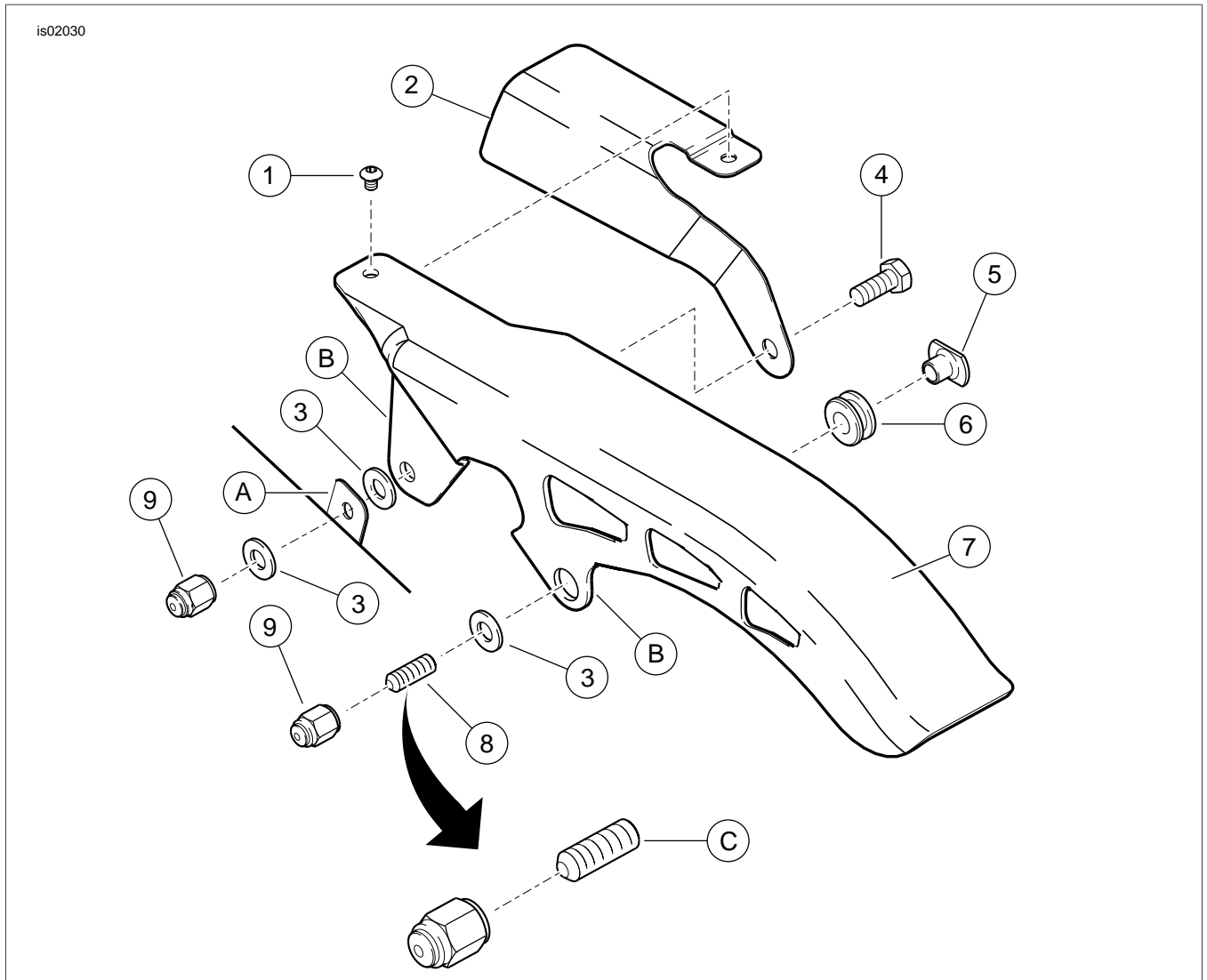

Figure 3. Service Parts: Chrome Belt Guard - Kits 60610-02A, 60610-07, 60649-07

See Table 1 for kit contents.



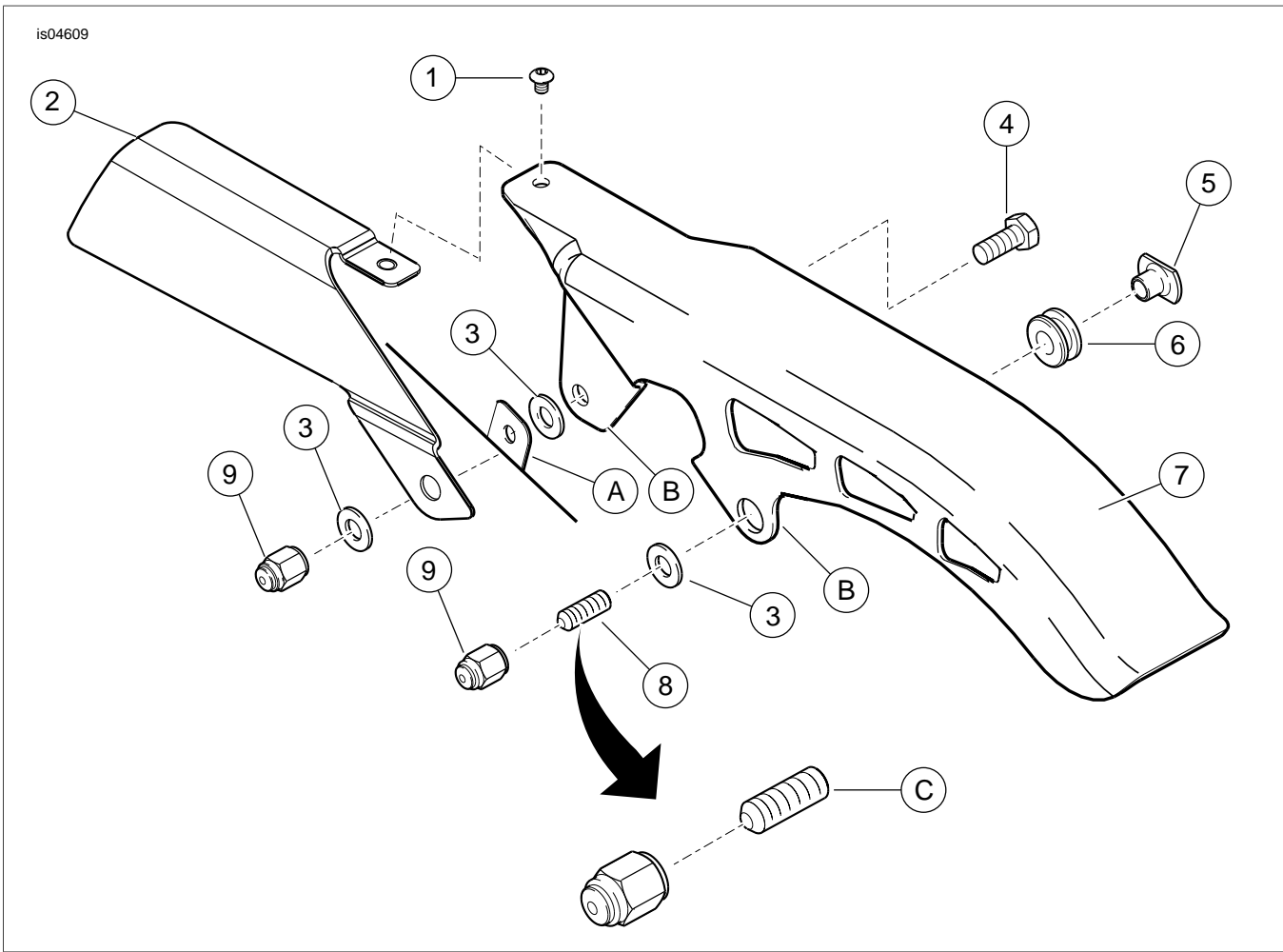

Figure 4. Service Parts: Belt Guard - Kits 60490-08 & 60300004

Table 1. Service Parts: Belt Guard

Item	Description (Quantity)	Part Number	Item	Description (Quantity)	Part Number
1	Capscrew, button head, chrome #10-32 x 0.25 inch	94590-98	8	Set screw, hex socket, 5/16-18 x 0.88 inch	Not Sold Separately
2	Belt guard, front-upper	Not Sold Separately	9	Cap nut, chrome, 5/16-18 (2)	8024
3	Washer, chrome, 5/16 inch (3)	3294	Parts not in kit:		
4	Screw, hex head, 5/16-18 x 0.75 inch	3987	A	Swingarm mounting tab	
5	Tee nut, 5/16-18	7669	B	Rear tab (2)	
6	Grommet, black rubber	11413	C	Socket end of set screw	
7	Belt guard, rear-upper	Not Sold Separately			

