



INSTRUCTIONS

-J04361

REV. 2006-12-13

CHROME PRIMARY COVER HARDWARE KIT

GENERAL

Kit Number

60607-08

Models

For model fitment information, please see the P&A Retail Catalog or the Parts and Accessories section of www.harley-davidson.com (English only).

Kit Contents

See Figure 1 and Table 1.

Table 1. Kit Contents

Description (Quantity)	Part Number
Screw, hex socket head, 1/4-20 x 1-3/8 inch (chrome) (9)	3125
Screw, hex socket head, 1/4-20 x 4-1/2 inch (chrome) (4)	3096
Screw, button head, TORX® 1/4-20 x 11/16 inch (chrome) (5)	94292-04
Washer, flat (chrome) (18)	94062-03

INSTALLATION

⚠ WARNING

To prevent accidental vehicle start-up, which could cause death or serious injury, disconnect negative (-) battery cable before proceeding. (00048a)

1. Disconnect battery cable, negative (-) cable only.

NOTES

Replace existing zinc hardware with chrome plated hardware one at a time so the primary chaincase and clutch cover gaskets do not need to be replaced.

2. Remove and discard existing nine 1/4-20 x 1-3/8 inch hex socket head screws with captive washers from chaincase.

3. Install nine 1/4-20 x 1-3/8 inch chrome hex socket head screws (1) and washers (2) on chaincase (3). Tighten screws to 108-120 **in-lbs** (12.2-13.6 Nm).
4. Remove and discard existing four 1/4-20 x 4 inch hex socket head screws with captive washers from chaincase.
5. Install four 1/4-20 x 4-1/2 inch chrome hex socket head screws (4) and washers (2) on chaincase (3). Tighten screws to 108-120 **in-lbs** (12.2-13.6 Nm).
6. Remove and discard existing five 1/4-20 x 11/16 in. button head TORX® screws with captive washers from clutch cover.
7. Install five chrome button head TORX screws (5) and washers (2) on clutch cover (6). Tighten screws to 84-108 **in-lbs** (9.5-12.2 Nm).
8. Connect negative (-) battery cable.

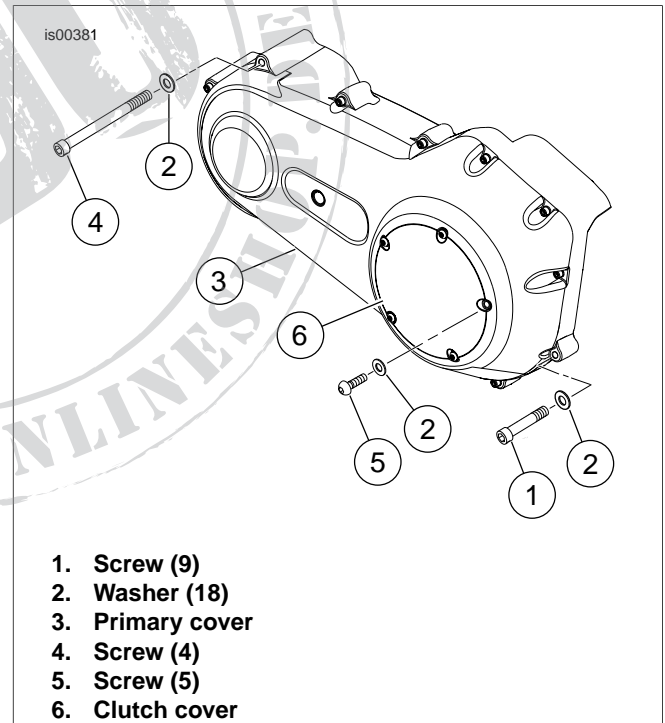

Figure 1. Primary Cover and Hardware