



# INSTRUCTIONS

-J04190

REV. 2006-05-17

## TOURING LAYBACK LICENSE PLATE MOUNTING KIT

### GENERAL

#### Kit Number

60210-07

#### Models

This kit fits all 1999 and later FLHR (Road King®) models, FLTR (Road Glide®) and FLHT (Electra Glide® standard) models having license plates measuring a maximum of 7-1/4 x 4-1/4 inches (184 x 108 mm). Also fits **2003** FLHRSE1<sup>2</sup> (Screamin' Eagle® Road King).

Does not fit with Detachable Tour-Pak Rack, part number 53276-04. Does not fit **2002** FLHRSE1 (Screamin' Eagle Road King).

#### Kit Contents

See Figure 1.

### INSTALLATION

1. Remove the license plate from the vehicle (if installed). Remove the two hex head bolts holding the original equipment (O.E.) license-plate bracket in place. The bolts and license-plate bracket can be discarded.
2. See Figure 1. Install the new layback license plate holder (1) using the button-head hex socket screws (3) from the kit. Tighten the screws to 19 ft-lbs (25.8 Nm).

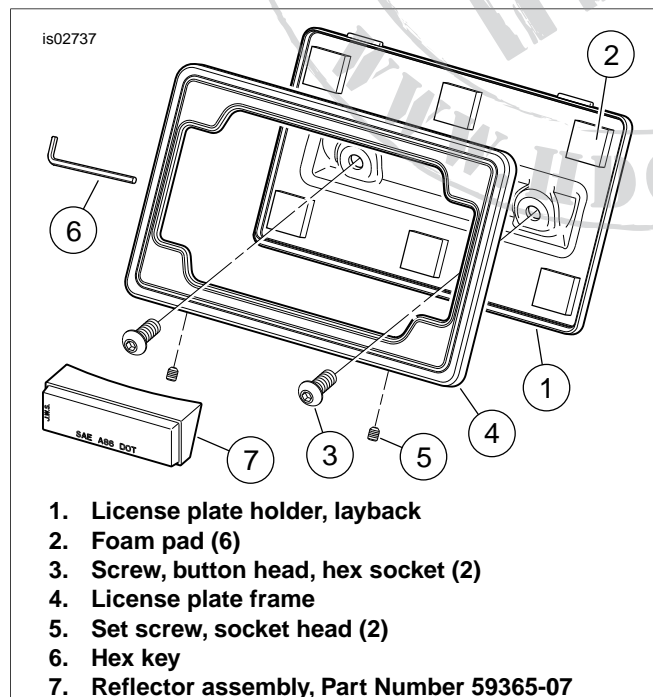

Figure 1. Layback License Plate Mount Components

3. Position the license plate onto the foam pads (2) of the license plate holder, centering and aligning the plate parallel to the holder edges for best appearance.

#### NOTE

Slots in the inside top edge of the license plate frame (4) fit over the two tabs on the top edge of the license plate holder.

4. Hook the top of the license plate frame over the top edge of the holder. Swing the bottom edge of the frame inward, holding the license plate in position against the pads.
5. Use the hex key (6) from the kit to securely fasten the license plate frame to the holder with the two socket head set screws (5).

### WARNING

**Federal Motor Vehicle Safety Standard (FMVSS) 108 requires motorcycles to be equipped with rear and side reflectors. Be sure rear and side reflectors are properly mounted. Poor visibility of rider to other motorists can result in death or serious injury. (00336b)**

#### NOTE

Ambient temperature should be **at least 60° F (16° C)** for proper adhesion of the reflector assembly (6) to the rear fender.

6. Clean the rear fender area beneath the tail lamp with a mixture of 50 to 70% isopropyl alcohol and 30 to 50% distilled water. Allow to dry thoroughly.
7. Before removing the adhesive backing of the reflector assembly, test fit the reflector to the fender, centered from left to right, so the reflector surface is parallel to the face of the tail lamp lens.
  - a. Measure and lightly mark the centerline of the black reflector base, tail lamp lens, and the rear fender below the tail lamp with a wax pencil or water-based marker.
  - b. Use a straight-edge to find a location on the fender one inch (25.4 mm) below the bottom edge of the tail lamp lens at the centerline as indicated in Figure 2. Do not follow the curve of the fender, but measure straight vertically. Make a horizontal mark on the fender at this location.
  - c. Position the reflector to the rear fender, with the top of the black base at the horizontal mark. Verify that the reflector surface is parallel to the face of the tail lamp lens, adjusting the position of the reflector up or down slightly on the fender as necessary to become parallel. Mark the final location of the reflector on the fender.
  - d. Remove un-needed markings from the fender and reflector base, and clean any dirt or grease from the fender in the reflector mounting area.

is02760

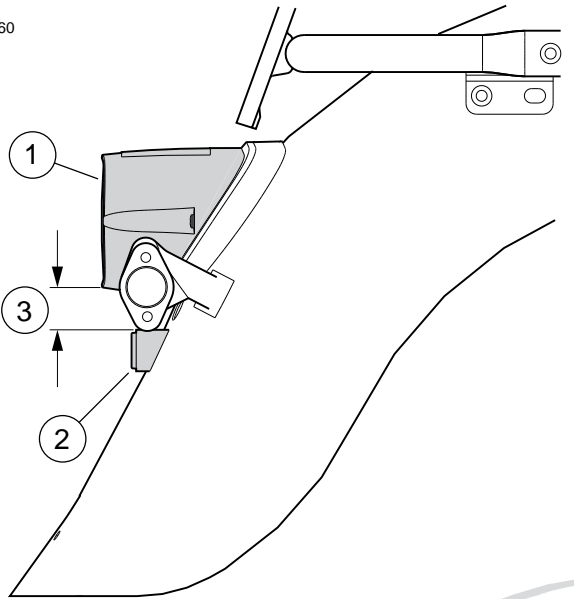

1. Tail/ stop lamp lens
2. Reflector assembly
3. Vertical measure one inch (25.4 mm)

Figure 2. Reflector Mounting

8. Peel the liner from the adhesive backing of the reflector assembly. Carefully position the reflector to the rear fender, and press firmly into place. Hold the reflector in position with steady pressure for five minutes to ensure proper adhesion.

**NOTE**

*Allow AT LEAST 24 hours after applying the reflector before exposing the area to vigorous washing, strong water spray or extreme weather.*

The adhesive bond will increase to maximum strength after about 72 hours at normal room temperature.

