



# INSTRUCTIONS

-J05779

2013-04-04

## AIR WING FRONT FENDER RAIL

### GENERAL

#### Kit Number

59600022

#### Models

For model fitment information, see the P&A retail catalog or the Parts and Accessories section of [www.harley-davidson.com](http://www.harley-davidson.com) (English only).

#### Installation Requirements

Loctite® 271 High Strength Threadlocker and Sealant - Red (Part No. 99671-97) is required for proper installation of this kit.

#### Kit Contents

See Figure 1 and Table 1.

### INSTALLATION

1. Remove the nuts that attach the fender tip to the fender. Leave fender tip installed. Do not discard.
2. Remove the two forward facing screws that mount fork sliders to fender and discard.
3. Install rail casting underneath fender to fender tip studs through holes (A). Attach nuts to the studs again. Do not tighten.
4. Apply a few drops of Loctite® 271 High Strength Threadlocker and Sealant - Red on two socket head cap screws (3). Attach rails to inside of fender using socket head cap screw (3), washer (1) and flange nut (4).

5. Remove two rear facing screws that mount fender to fork sliders and discard. Apply Loctite® 271 High Strength Threadlocker and Sealant - Red on the two socket head cap screws (3). Install the two socket head cap screws (3) and washer (1). Do not tighten.
6. Center the fender about the tire.
7. Tighten all four socket head cap screws (3) 19–24.4 N·m (16–20 ft-lbs).
8. Tighten fender tip nuts to 13.6 N·m (20–25 in-lbs).

### SERVICE PARTS

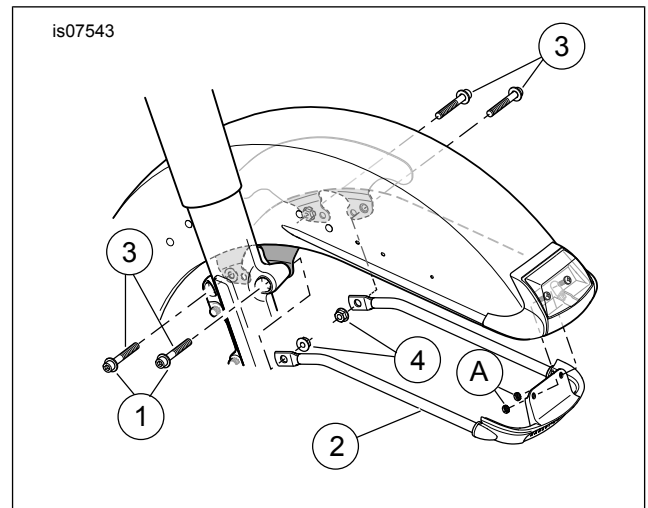

Figure 1. Service Parts: Air Wing Front Fender Rail Kit

Table 1. Service Parts Table

Item	Description (Quantity)	Part Number
1	Plain washer, type A (4)	6702
2	fender rail	Not Sold Separately
3	Socket head cap screw (4)	10200267
4	Flange nut (2)	7531
<b>Items mentioned in text, but not included in kit:</b>		
A	Slotted holes in front tip	

