



INSTRUCTIONS

-J02826

REV. 2005-11-29

DETACHABLE WINDSHIELD AND DOCKING HARDWARE KIT

GENERAL

Kit Number

58865-03, 58880-03, 58362-03

Models

These kits fit 1984 and later FXST, FXSTB, FXSTC, and 1993 and later FXDWG model motorcycles when equipped with passing lamps.

Table 1. Models

Kits	Contents
58865-03	Clear standard height windshield
58880-03	Smoked standard height windshield

Kit 58362-03 contains the docking hardware required to mount the above windshields kits.

Additional Parts Required

NOTE

If passing lamps are being installed at the same time, you will need the Turn Signal Relocation Kit (Harley-Davidson Part No. 68603-01) available at any Harley-Davidson dealer.

WARNING

The rider's safety depends upon the correct installation of this kit. Use the appropriate service manual procedures. If the procedure is not within your capabilities or you do not have the correct tools, have a Harley-Davidson dealer perform the installation. Improper installation of this kit could result in death or serious injury. (00333a)

NOTE

This instruction sheet references Service Manual information. A Service Manual for your model motorcycle is required for this installation and is available from a Harley-Davidson Dealer.

Kit Contents

See Figure 4 and Table 2, Figure 5 and Table 3.

INSTALLATION

1. To protect against scratches, cover gas tank and front fender before installation.

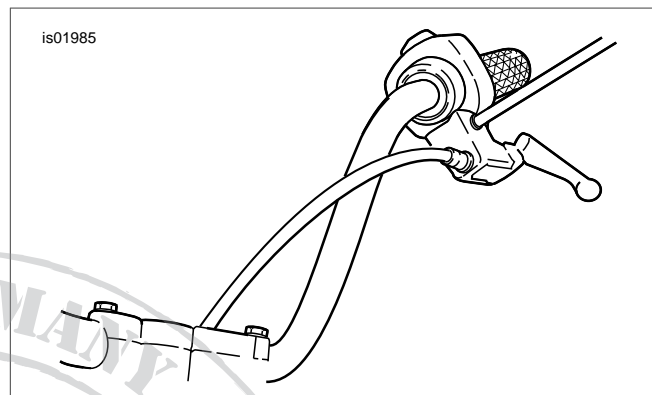

Figure 1. New Clutch Cable Routing

2. **For FXSTB Models:** Proceed to Step 3.
For all except FXSTB: See Figure 1. Relocate the clutch cable to the inside of the handlebars as follows:
 - a. Locate cable adjuster halfway along clutch cable by the front frame downtube and slide off rubber boot.
 - b. Holding cable adjuster with 1/2 inch wrench, loosen jam nut using a 9/16 inch wrench. Back jam nut away from cable adjuster. Move adjuster toward jam nut to introduce a large amount of free play at hand lever.
 - c. Remove small snap ring from pivot pin groove at bottom of clutch lever bracket. Remove pivot pin and clutch hand lever from bracket. Remove anchor pin and clutch cable eyelet from clutch hand lever.
 - d. See Figure 1. Route clutch cable to the inside of the handlebars and reconnect clutch cable to clutch lever.
 - e. See Figure 2. Turn cable adjuster away from jam nut until slack is eliminated at hand lever. Pull clutch cable ferrule away from clutch lever bracket to check free play. Turn cable adjuster to obtain 1/16-1/8 inch (1.6-3.2 mm) free play between end of cable ferrule and clutch lever bracket.
 - f. Hold adjuster with 1/2 inch wrench. Using 9/16 inch wrench, tighten jam nut against cable adjuster. Cover cable adjuster mechanism with rubber boot.

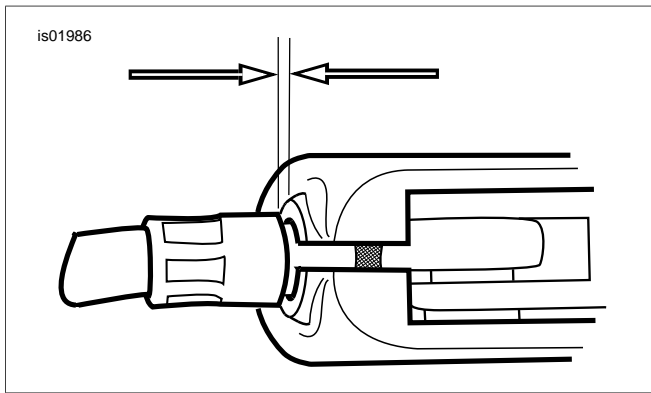

Figure 2. 1/16-1/8 inch (1.6-3.2 mm) Clutch Cable Free Play

3. **On FXSTB models only:** Remove existing turn signal clamps from fork tubes. Remove the original turn signal standoff from the turn signal. The original clamp and standoff will not be used during re-assembly.
4. See Figure 4. Assemble mounting hardware for lower windshield mounting. Assemble in the following order, and leave assembly loose:
 - a. Locate the mounting hardware supplied in the docking hardware kit.
 - b. Place flatwasher (5) and bushing (4) on bolt (3) and install on clamp.
 - c. Install clamp assembly onto the fork tube with the clamp nut forward toward the headlamp.
5. See Figure 5. Assemble hardware for upper windshield mounting as shown in illustration and tighten buttonhead screws to 15 ft-lbs (20 Nm). The spacer (1), not visible in the illustration, fits between the retainer wire bracket (6, 7) and the upper fork triple clamp.

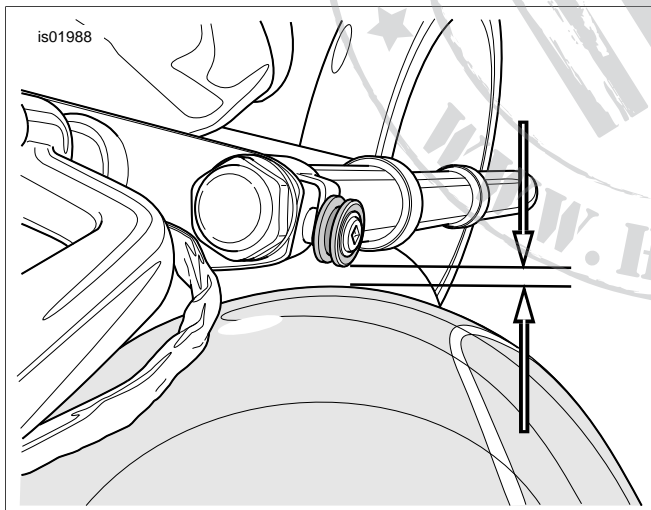

Figure 3. Measuring Clearance (looking down on docking point from above)

NOTE

Check for proper clearance between upper bushing and fuel tank before installing windshield as follows: See Figure 3. Turn the front forks to the left, allowing the fork to rest against the fork stop. Measure the clearance between the fuel tank and the upper bushing. We recommend using the shank end of the proper size drill bit as a feeler gauge between the fuel tank and

the upper bushing. Before checking the clearance, place a piece of masking tape against the fuel tank to eliminate the possibility of scratching the fuel tank paint. Repeat this process with the front forks rotated fully to the right fork stop. If clearance is less than 5/32 inch (4 mm), contact your Harley-Davidson Dealer for additional information (reference P&A Service Bulletin P-40).

6. Hook the two top windshield assembly "jaws" into the grooves of the top bushings (4, in Figure 4) then slide the lower clamp assemblies up until the lower bushings firmly fit into the lower windshield "jaws".
7. With windshield in place, tighten lower mounting clamp (8) hardware by first tightening clamp nut to 10 ft-lbs (14 Nm). Be sure the clamp does not rotate during tightening (**NOTE:** The mounting bushings must be parallel to the windshield brackets).
8. Remove windshield by grabbing windshield edges parallel with center brace and firmly pulling windshield loose from upper bushing grooves. Lift windshield assembly off of lower bushings.
9. Reattach brake line clamp to upper fork triple clamp.
10. If necessary, follow directions provided in Turn Signal Relocation Kit and install the turn signals.

WARNING

Improper installation of accessories or loading of cargo can affect motorcycle stability and handling, which could result in death or serious injury. (00455b)

WARNING

Failure to provide adequate clearance between stationary and moving parts can cause loss of control, which could result in death or serious injury. (00378a)

NOTE

Inspect windshield upon completion of installation. Be sure windshield mounting does not restrict full left or full right movement of front fork assembly. Restricted movement could affect handling, resulting in death or serious injury. If restriction does occur, adjust windshield as needed until proper clearance is obtained. Have experienced Harley-Davidson service personnel correct any problems before riding with this accessory installed.

NOTE

Check mounting hardware periodically. Never ride with loose mounts. A loose mounting causes extra stress on all other mounts, as well as the windshield itself, and could result in premature failure of components.

CARE AND CLEANING

NOTE

Sunlight reflections off of the inside curvature of a windshield can, at certain times of the day, cause extreme heat build-up on motorcycle instruments. Exercise care in parking. Park facing the sun, place an opaque object over the instruments, or adjust the windshield to avoid reflections.

CAUTION

Harley-Davidson windshields are made of Lexan. Lexan is a more durable and distortion-resistant material than other types of motorcycle windshield material, but still requires attention and care to maintain. Failure to maintain Lexan properly can result in damage to the windshield. (00230a)

CAUTION

Do not use harsh chemicals including rain sheeting products on Harley-Davidson windshields. They can cause dulling or hazing. If you want to use a windshield protectant on your windshield, try Harley Glaze Polish and Sealant (00231a)

CAUTION

Do not use benzine, paint thinner, gasoline or any other type of harsh cleaner on the windshield. Doing so will damage the windshield surface. (00232a)

Do not clean Lexan® polycarbonate in hot sun or high temperature. Powdered, abrasive or alkaline cleanser will damage the windshield. Never scrape the windshield with a razor blade or other sharp instruments because permanent damage will result.

NOTES

Covering the windshield with a clean, wet cloth for about 15 minutes before washing will make dried bug removal easier.

Harley-Davidson Windshield Water Repellent Treatment Part Number 99841-01 is approved for use on Harley-Davidson Lexan® windshields.



SERVICE PARTS

is02108

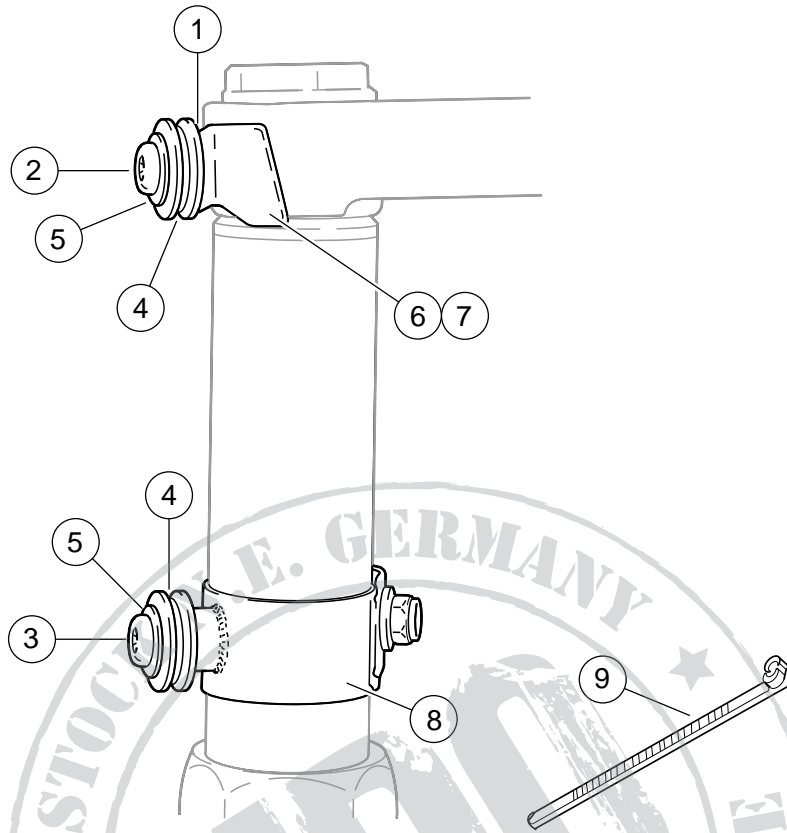

Figure 4. Service Parts: Docking Hardware Kit

Table 2. Service Parts: Docking Hardware Kit

Item	Description (Quantity)	Part Number
1	Spacer (2) - behind bracket	58349-96
2	5/16-24 x 7/8 inch buttonhead screws (2)	94467-94T
3	Screw (2)	94468-94T
4	Bushings (4)	67621-94
5	5/16 inch chrome flat washers (4)	94066-90T
6	Left retainer wire bracket	58514-96
7	Right retainer wire bracket	58515-96
8	Mounting clamps (2)	58351-96
9	Cable ties (6)	10006

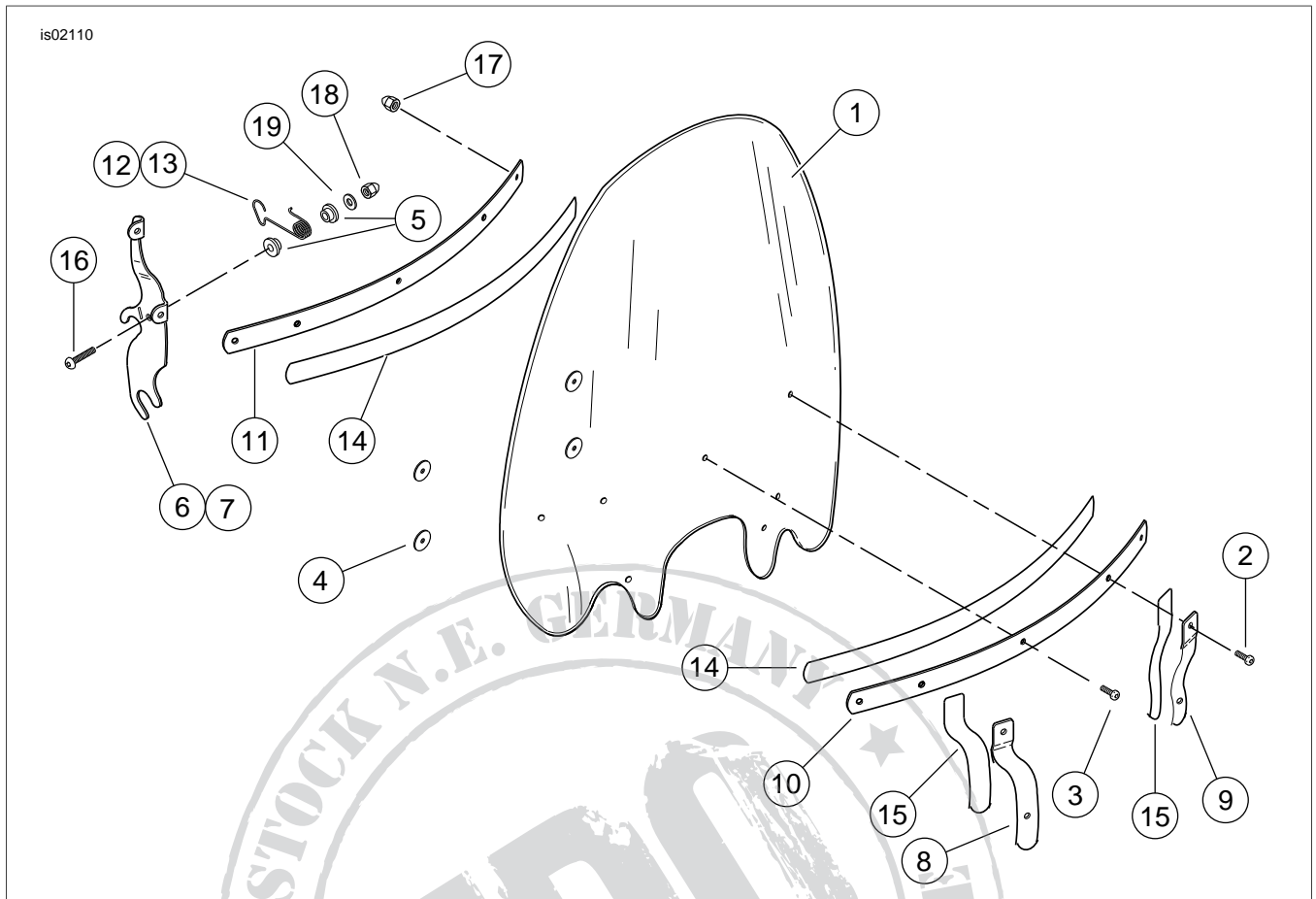

Figure 5. Service Parts: Windshield Kit

Table 3. Service Parts: Windshield Kit

Item	Description (Quantity)	Part Number	Item	Description (Quantity)	Part Number
1	Windshields		10	Outer horizontal trim strip	58051-78A
	Kit Number 58865-03 clear	58265-03	11	Inner horizontal trim strip	58050-78A
	Kit Number 58880-03 smoked	58264-03	12	Wireform, left	58329-96
2	Panhead screws, TORX (2)	2452	13	Wireform, right	58328-96
3	Panhead screws, TORX (5)	2921	14	Horizontal tape (2)	58052-78
4	Washers (4)	58152-96	15	Vertical tape (2)	59415-03
5	Nylon bushings (4)	58272-95	16	Buttonhead screws (2)	94426-95
6	Bracket, right	58881-03	17	Acorn nuts (7)	7651
7	Bracket, left	58913-03	18	Acorn nuts, 1/4-20 (2)	94004-90T
8	Outer trim strip, right	58979-03	19	Flatwashers (2)	6703
9	Outer trim strip, left	59073-03			