



INSTRUCTIONS

-J04015

REV. 2006-02-21

ROAD GLIDE INNER FAIRING

GENERAL

Kit Number

58663-07XXX

NOTE

This instruction sheet covers a large number of inner fairing kits with the color being the only difference between kits. The "XXX" denotes the last three letters for each kit based on the paint color for each kit.

Models

These kits fit 1998 and later FLTRI (Road Glide) Touring Model motorcycles.

Additional Parts Required

See Figure 1. When removing the inner fairing components, retain items A through E for installation of the new inner fairing.

WARNING

The rider's safety depends upon the correct installation of this kit. Use the appropriate service manual procedures. If the procedure is not within your capabilities or you do not have the correct tools, have a Harley-Davidson dealer perform the installation. Improper installation of this kit could result in death or serious injury. (00333a)

NOTE

This instruction sheet references Service Manual information. A Service Manual for your model motorcycle is required for this installation and is available from a Harley-Davidson Dealer.

Kit Contents

See Figure 1 and Table 1.

INSTALLATION

1. See appropriate CHASSIS section in the Service Manual for instructions to remove original equipment outer and inner fairing.

NOTE

Once the outer and inner fairing have been removed, it will be necessary to transfer all of the gauges, switches and associated hardware from the original inner fairing to the new inner fairing in the order they are removed from the original inner fairing.

NOTE

The left and right storage box cover barrel hinges are spring loaded. Care must be taken when removing them from the original fairing storage box covers.

2. Transfer all gauges, switches and associated hardware from the original fairing to the new fairing.
3. Install the fairing door bumpers (4) (2 per cover) onto the new fairing.

NOTE

For steps 4 and 5, refer to the GLOVE BOX DOOR/HINGE Removal and Installation procedures in the CHASSIS section of the Service Manual.

4. Install the storage box cover hinge and hardware to the new left and right storage box covers before installing covers onto inner fairing.
5. See Figure 1. Install the right hand storage box cover (2) and left hand storage box cover (3) on the new inner fairing using the saved hardware.
6. Clean outside edge surface of the new inner fairing (1) with a 50/50 isopropyl alcohol/water solution in preparation for installing the rubber trim molding. Allow surface to dry thoroughly.
7. Test the correct placement of side trim rubber molding (6), with the long side of the strip channel of the inside of the fairing edge, before installation.
8. Test the correct placement of top trim rubber molding (5).

NOTE

The trim rubber molding is ready for installation with no additional adhesive.

The ideal temperature should be at least 60°F (16°C) for proper adhesion of the molding on the inner fairing.

9. Place side rubber trim molding on the fairing edge. Start at the top side of the fairing and push the trim molding onto the fairing edge, being careful not to stretch the trim rubber molding. Continue from top to bottom. Use appropriate tool to trim off any extra molding.
10. Using the original inner fairing top rubber trim molding as a visual guide, place the top rubber trim molding on center and apply equal pressure towards the left and right edges of the inner fairing.
11. Allow adhesive to cure for 24 hours at no less than 60°F (16°C).
12. See appropriate CHASSIS section in the Service Manual for instructions to install inner and outer fairing.

SERVICE PARTS

is03133

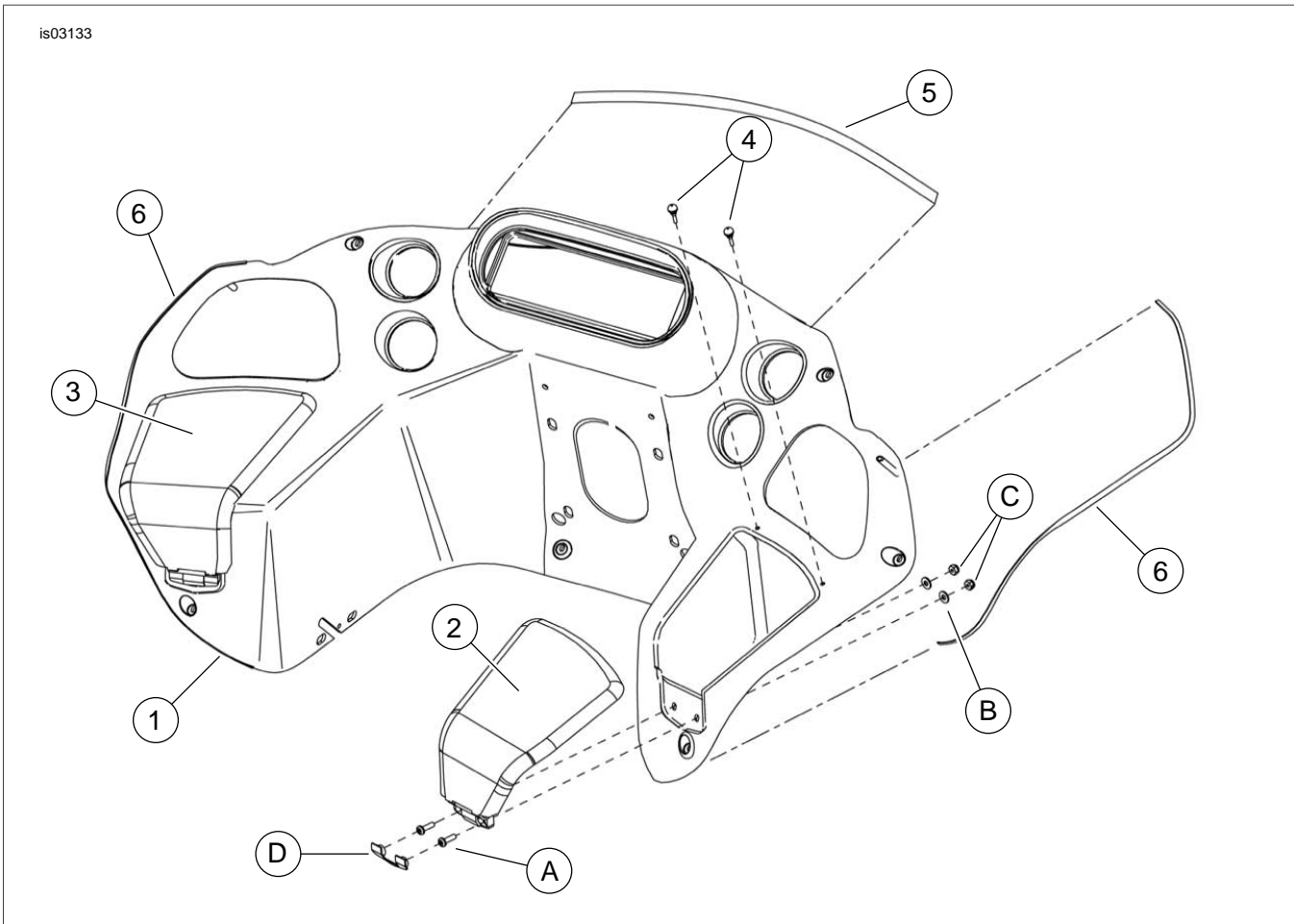

Figure 1. Service Parts: Road Glide Inner Fairing

Table 1. Service Parts Table

Item	Description (Quantity)	Part Number
1	Fairing, Inner	Not Sold Separately
2	Cover, storage box, right hand	58727-07XX
3	Cover, storage box, left hand	58728-07XX
4	Bumper, fairing door (2 per cover)	58888-98A
5	Top trim	64256-98
6	Side trim (2)	58359-98
Items mentioned in text, but not included in kit:		
A	Screw, pan (2 per cover)	2665
B	Washer (2 per cover)	6716
C	Nut, hex lock (2 per cover)	7624
D	Hinge cover storage box (2)	58459-98
E	Barrel hinge (4) (not shown)	64255-98

