



INSTRUCTIONS

-J03583

REV. 2005-05-23

TURN SIGNAL RELOCATION KIT

GENERAL

Kit Number

58742-05

Models

This turn signal relocation kit fits 1984 and later FXST, FXSTC and FXSTB models; 2000 and later FXSTD and 1993-2005 FXDWG models.

This kit is a necessary addition when installing Quick Release Windshields 59802-05, 58751-05, 57199-05, 58779-05 or 57160-05 on these models.

Installation of this kit will relocate the turn signals to one of the motorcycle's triple clamps.

⚠ WARNING

The rider's safety depends upon the correct installation of this kit. Use the appropriate service manual procedures. If the procedure is not within your capabilities or you do not have the correct tools, have a Harley-Davidson dealer perform the installation. Improper installation of this kit could result in death or serious injury. (00333a)

NOTE

This instruction sheet references Service Manual information. A Service Manual for your model motorcycle is required for this installation and is available from a Harley-Davidson Dealer.

Kit Contents

See Figure 3 and Table 1.

INSTALLATION

Removing the Turn Signals - All models except FXSTB

1. Refer to the Service Manual and follow the instructions to remove the seat. Retain all seat mounting hardware.

⚠ WARNING

When servicing the fuel system, do not smoke or allow open flame or sparks in the vicinity. Gasoline is extremely flammable and highly explosive, which could result in death or serious injury. (00330a)

2. Remove the fuel tank. Refer to FUEL TANK REMOVAL in the appropriate section (Carbureted or EFI Engine) of the Service Manual.

⚠ WARNING

To prevent accidental vehicle start-up, which could cause death or serious injury, disconnect battery cables (negative (-) cable first) before proceeding. (00307a)

⚠ WARNING

Disconnect negative (-) battery cable first. If positive (+) cable should contact ground with negative (-) cable connected, the resulting sparks can cause a battery explosion, which could result in death or serious injury. (00049a)

3. Remove the 40 amp Maxi-Fuse or disconnect the battery cables, negative cable first.
4. See Figure 1. Release turn signal lamp from left side of handlebar by removing the left side turn signal mount (2) (jam nut, ball stud, clamp and ball receptacle). Re-install stock lockwasher and acorn nut to secure mirror.

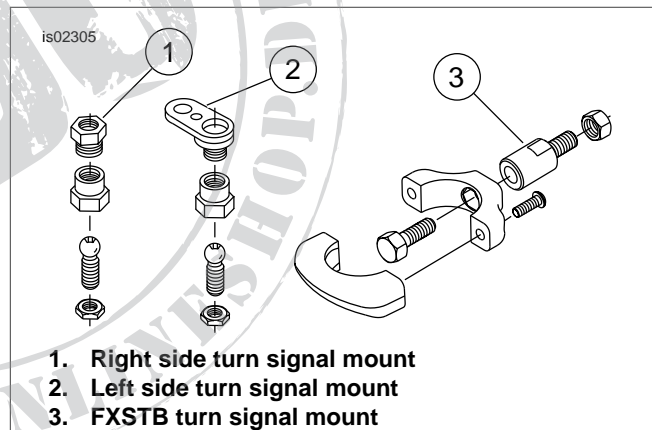

Figure 1. Remove Existing Turn Signal Mount

5. See Figure 1. Release turn signal lamp from right side of handlebar by removing the right side turn signal mount (1) (jam nut, ball stud, clamp and retainer). Install lockwasher and chrome acorn nut from kit.
6. Remove brake line clamp on lower fork triple clamp to allow right turn signal wiring to pass between brake line and right handlebar riser.
7. Remove turn signal wiring from connection under fuel tank.
 - a. Locate turn signal connector [31B] and disconnect from socket [31A]. Note left and right turn signal wire locations. Follow instructions in Service Manual under Multilock Electrical Connectors (Socket Terminal Removal/Installation) and remove left and right front turn signal socket terminals from connector.
 - b. Carefully remove wiring from its route to the handlebar position.

Removing the Turn Signals - FXSTB Only

On FXSTB models only: See Figure 1. Release turn signal lamps from fork tube by removing the existing turn signal mounts (3) (screws, clamps, standoffs and nuts).

Relocating the Turn Signals - All Models

1. See Service Parts illustration. Install each turn signal as follows:
 - a. Assemble the turn signal, toothed lockwasher (2), relocation stalk (1), lockwasher (6) and small cap screw (5) as shown.
 - b. Remove the pinch bolt attached to the back side of the triple clamp.
 - c. On all models except FXSTD: Replace the pinch bolt with the spacer (7), turn screw assembly, lockwasher (4) and larger cap screw (3). Tighten only enough to hold in place. On FXSTD models: Omit spacer (7).
 - d. Hold motorcycle in upright position and align turn signal to vehicle orientation. Torque turn signal screw to 8-10 ft-lbs (11-14 Nm).
 - e. Torque pinch bolt cap screw (3) to 30-35 ft-lbs (41-47 Nm).
 - f. See Figure 2. Use tie wraps to secure the turn signal wiring to the stalk and triple clamp.

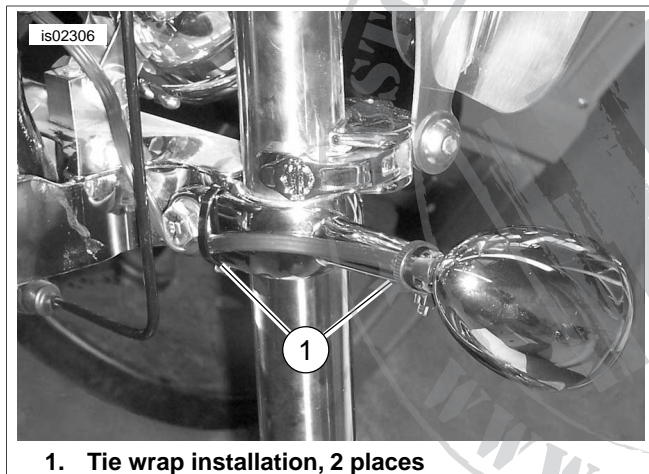

1. Tie wrap installation, 2 places

Figure 2. Secure Wiring

2. On all models except FXSTB: Route the turn signal wiring as follows:
 - a. Route the wiring for the left and right turn signals in front of the steering head and join together with a tie wrap.
 - b. Route the joined wires back to turn signal connector [31A]. Add tie wraps if necessary to secure.
 - c. Follow instructions in Service Manual under Multilock Electrical Connectors (Socket Terminal Removal/Installation) and install left and right front turn signal socket terminals to the turn signal connector [31B]. Plug the connector into socket [31A].
 - d. Bundle the excess wiring and turn the handlebars all of the way to the right and left to ensure free movement.
3. Refer to the Service Manual and follow the instructions given to re-connect the Maxi-Fuse and install the fuel tank.

⚠ WARNING

Be sure that all lights and switches operate properly before operating motorcycle. Low visibility of rider can result in death or serious injury. (00316a)

4. On all models, check turn signals for proper operation.

SERVICE PARTS

is02308

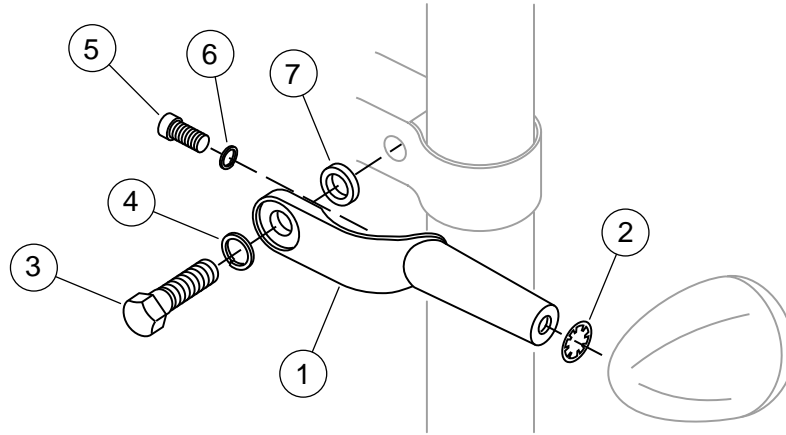

Figure 3. Service Parts: Turn Signal Relocation Kit

Table 1. Service Parts Table

Item	Description (Quantity)	Part Number	Item	Description (Quantity)	Part Number
1	Turn signal relocation stalk (2)	58743-05	6	Lockwasher, helical 5/16 (2)	7042
2	Lockwasher, internal tooth, 5/16 (3) (one used on right side mirror)	7127	7	Spacer	58746-05
3	Screw, hex head, 7/16-24 x 1-3/4 inch (2)	4787	8	Acorn nut, 5/16-24 (not shown) (used on right side mirror)	7736
4	Lockwasher, helical 7/16 (2)	7039	9	Cable strap (6) (not shown)	10006
5	Screw, socket head cap, 5/16-24 x 5/8 inch (2)	2698A	Note: Appearance of actual components may vary from illustration.		