



# INSTRUCTIONS

-J00315

REV. 2006-01-13

## FLHR/FLHP WINDSHIELD KITS

### GENERAL

#### Kit Number

57768-00, 57809-04, 57921-98, 57924-98, 58135-94, 58193-94, 58194-94, 58195-94, 58327-97, 58327-06, 58433-96

#### Models

These kits fit 1994 and later FLHR models, and 1996 and later FLHP model motorcycles.

Table 1. Models

Kits	Contents
57768-00	4 inches shorter than stock clear FLHR windshield
57809-04	Stock height clear FLHR windshield with flames
57921-98	2 inches taller than stock clear FLHR windshield (International)
58193-94	Stock height clear FLHR windshield
58327-97	Stock height clear FLHR windshield (International)
58327-06	2 inches shorter than stock (International)
58433-96	2 inches taller than stock clear FLHR windshield
58135-94	Stock height smoked FLHR windshield
58194-94	2 inches taller than stock smoked FLHR windshield
58195-94	4 inches shorter than stock smoked FLHR windshield
57924-98	4 inches shorter than stock height smoked FLHR windshield (International)

### CAUTION

**Do not use windshield bags with flamed windshields. Damage to graphics will occur. (00393f)**

#### Kit Contents

See Figure 1 and Table 2.

### INSTALLATION

- Remove stock windshield.
- Remove all hardware that secures the mounting brackets to the windshield. The nine screws that must be removed require a T-27 TORX® screwdriver. Save all hardware and brackets for installing the new windshield.
- Remove all old tape from the brackets. Apply tape from kit to areas of the new windshield that had tape on the stock windshield.

### CAUTION

**Do not exceed recommended torque when installing mounting screws. Damage to windshield can result. (00385a)**

- Install all brackets and tighten all screws and acorn nuts to 48-60 in-lbs (5.4-6.7 Nm).
- Install windshield on motorcycle.

### WARNING

**Improper installation of accessories or loading of cargo can affect motorcycle stability and handling, which could result in death or serious injury. (00455b)**

### WARNING

**Failure to provide adequate clearance between stationary and moving parts can cause loss of control, which could result in death or serious injury. (00378a)**

#### NOTE

*Inspect windshield upon completion of installation. Be sure windshield mounting does not restrict full left or full right movement of front fork assembly. If restriction does occur, adjust windshield as needed until proper clearance is obtained. Have experienced Harley-Davidson service personnel correct any problems before riding with this accessory installed.*

#### NOTE

*Check mounting hardware periodically. Never ride with loose mounts. A loose mounting causes extra stress on all other mounts, as well as the windshield itself, and could result in premature failure of components.*

### CARE AND CLEANING

#### NOTE

*Sunlight reflections off of the inside curvature of a windshield can, at certain times of the day, cause extreme heat build-up on motorcycle instruments. Exercise care in parking. Park facing the sun, place an opaque object over the instruments, or adjust the windshield to avoid reflections.*

### CAUTION

Harley-Davidson windshields are made of Lexan. Lexan is a more durable and distortion-resistant material than other types of motorcycle windshield material, but still requires attention and care to maintain. Failure to maintain Lexan properly can result in damage to the windshield. (00230a)

### CAUTION

Do not use harsh chemicals including rain sheeting products on Harley-Davidson windshields. They can cause dulling or hazing. If you want to use a windshield protectant on your windshield, try Harley Glaze Polish and Sealant (00231a)

### CAUTION

Do not use benzine, paint thinner, gasoline or any other type of harsh cleaner on the windshield. Doing so will damage the windshield surface. (00232a)

Do not clean Lexan® polycarbonate in hot sun or high temperature. Powdered, abrasive or alkaline cleanser will damage the windshield. Never scrape the windshield with a razor blade or other sharp instruments because permanent damage will result.

### NOTES

Covering the windshield with a clean, wet cloth for about 15 minutes before washing will make dried bug removal easier.

Harley-Davidson Windshield Water Repellent Treatment Part Number 99841-01 is approved for use on Harley-Davidson Lexan® windshields.

### SERVICE PARTS

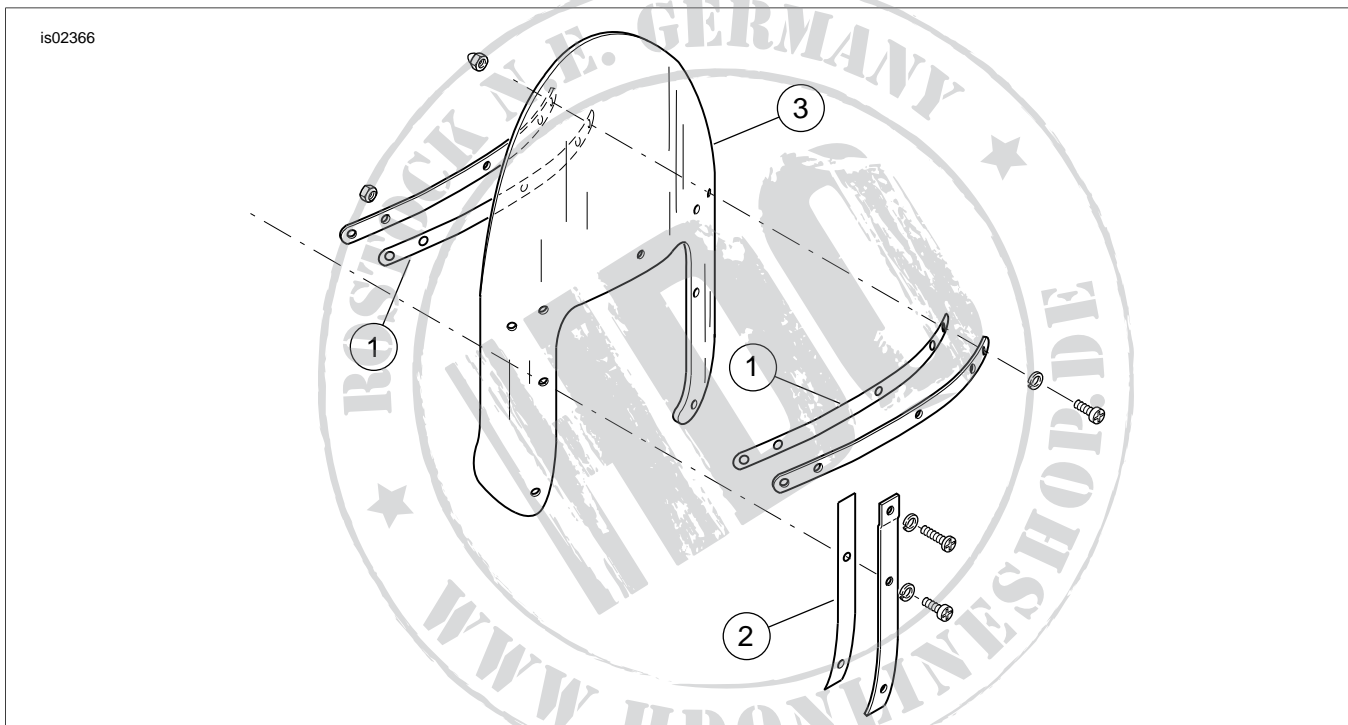

Figure 1. Service Parts: Windshield Kits

Table 2. Service Parts: Windshield Kits

Item	Description (Quantity)	Part Number
1	Tape for horizontal braces (2)	58416-77A
2	Tape for vertical braces (2)	58417-77
3	Windshield	Not Sold Separately

### NOTE

These Service Parts apply to all kits covered by this Instruction Sheet. See the applicable Parts Catalog for ordering information for braces and hardware shown above.